



CALL NO. 103

CONTRACT ID. 071211

CHRISTIAN COUNTY

FED/STATE PROJECT NUMBER BRZ 0203 (289)

LETTING DATE: March 23, 2007

Sealed Bids will be received in the Division of Construction Procurement and/or the Auditorium located on the 1st floor of the Transportation Cabinet Office Building until 10:00 AM EASTERN DAYLIGHT TIME March 23, 2007. Bids will be publicly opened and read at 10:00 AM EASTERN DAYLIGHT TIME.

ROAD AND/OR BRIDGE PLANS

DBE CERTIFICATION REQUIRED

REQUIRED BID PROPOSAL GUARANTY: Not less than 5% of the total bid.

(Check guaranty submitted: Cashier's Check Certified Check Bid Bond)

BID BONDS WHEN SUBMITTED WILL BE RETAINED WITH THE PROPOSAL

DBE General Plan Included

BID

PROPOSAL ISSUED TO: _____

SPECIMEN

Address

City

State

Zip

TABLE OF CONTENTS

PART I	SCOPE OF WORK
	<ul style="list-style-type: none">• PROJECT(S), COMPLETION DATE(S), & LIQUIDATED DAMAGES• CONTRACT NOTES• CONTRACT DBE GOAL• FEDERAL CONTRACT NOTES• GENERAL DBE PARTICIPATION PLAN• ASPHALT MIXTURE• DGA BASE• DGA BASE FOR SHOULDERS• INCIDENTAL SURFACING• FUEL AND ASPHALT PAY ADJUSTMENT• OPTION B• PROJECT IDENTIFICATION SIGN• WASTE AND BORROWED SITES• RIGHT OF WAY NOTES• UTILITY CLEARANCE• DEPT OF ARMY - NATIONWIDE PERMIT• WATER QUALITY CERTIFICATION• COMMUNICATING ALL PROMISES
PART II	SPECIFICATIONS AND STANDARD DRAWINGS
	<ul style="list-style-type: none">• SUPPLEMENTAL SPECIFICATIONS• [SP-69] EMBANKMENT AT BRIDGE END BENT STRUCTURES• BREAKAWAY SIGN SUPPORT SYSTEM FOR TYPE C BEAM• FOOTING DETAILS FOR TYPE C BEAM
PART III	EMPLOYMENT, WAGE AND RECORD REQUIREMENTS
	<ul style="list-style-type: none">• FEDERAL-AID CONSTRUCTION CONTRACTS - FHWA 1273• NONDISCRIMINATION OF EMPLOYEES• EXECUTIVE BRANCH CODE OF ETHICS• PROJECT WAGE RATES• NOTICE OF REQUIREMENT FOR AFFIRMATIVE ACTION TO ENSURE EEO
PART IV	INSURANCE
PART V	STATEMENT OF INCOMPLETED WORK
PART VI	BID ITEMS

PART VII CERTIFICATION

- **PROVISIONS RELATED TO SENATE BILL 258 (1994)**
- **NON-COLLUSION CERTIFICATION**
- **CERTIFICATION OF ORGANIZATION(S)**
- **CERTIFICATION OF PERFORMANCE**
- **CERTIFICATION FOR FEDERAL-AID CONTRACTS**
- **CERTIFICATION OF BID PROPOSAL / DBE**

PART I
SCOPE OF WORK

CONTRACT ID - 071211

ADMINISTRATIVE DISTRICT - 02

PROJECT(S) IDENTIFICATION AND DESCRIPTION:

COUNTY - CHRISTIAN

BRZ 0203 (289)

BARNETT ROAD (CR 1002) REPLACE BRIDGE OVER WEST FORK OF POND RIVER 200' SOUTH OF JUNCTION
WITH CR 1075, A DISTANCE OF 0.05 MILES. BRIDGE WITH GRADE, DRAIN & SURFACE. SYP NO.

02-01060.00.

GEOGRAPHIC COORDINATES LATITUDE 37^09'00" LONGITUDE 87^01'00"

COMPLETION DATE(S) AND LIQUIDATED DAMAGES ESTABLISHED:

COMPLETION DATE - July 31, 2007

APPLIES TO ENTIRE CONTRACT

SEE STANDARD SPECIFICATIONS FOR LIQUIDATED DAMAGES

CONTRACT NOTES

PROPOSAL ADDENDA

All addenda to this proposal must be incorporated into the proposal when the bid is submitted to the Kentucky Department of Highways. Failure to use the correct and most recent bid sheet(s) may result in the bid being rejected.

BID SUBMITTAL

Bidder must use the Department's Highway Bid Program available on the Internet web site of the Department of Highways, Division of Construction Procurement. (www.transportation.ky.gov/contract)

The Bidder must download the bid items created from the web site to prepare a bid proposal for submission to the Department. The bidder must insert the completed bid item sheets printed from the Program into the bidder's proposal and submit with the disk created by said program.

JOINT VENTURE BIDDING

Joint Venture bidding is permissible. However, both companies MUST purchase a bidding proposal. Either proposal may be submitted but must contain the company names and signatures of both parties where required. A joint bid bond of 5% may be submitted for both companies or each company may submit a separate bond of 5%.

UNDERGROUND FACILITY DAMAGE PROTECTION

The contractor is advised that the Underground Facility Damage Protection Act of 1994, became law January 1, 1995. It is the contractor's responsibility to determine the impact of the act regarding this project, and take all steps necessary to be in compliance with the provision of the act.

CONTRACT DBE GOAL

The Disadvantaged Business Enterprise (DBE) goal established for this contract is 3 % of the total value of the contract.

The contractor shall exercise all necessary and reasonable steps to ensure that Disadvantaged Business Enterprises participate in at least the percent of the contract as set forth above as goals for this contract.

FEDERAL CONTRACT NOTES

The Kentucky Department of Highways, in accordance with the Regulations of the United States Department of Transportation 23 CFR 635.112 (h), hereby notifies all bidders that failure by a bidder to comply with all applicable sections of the 2004 Kentucky Standard Specifications, including, but not limited to the following, may result in a bid not being considered responsive and thus not eligible to be considered for award:

102.02 Current Capacity Rating
102.08 Irregular Proposals
102.09 Proposal Guaranty

102.10 Delivery of Proposals
102.14 Disqualification of Bidders

CIVIL RIGHTS ACT OF 1964

The Kentucky Department of Highways, in accordance with the provisions of Title VI of the Civil Rights Act of 1964 (78 Stat. 252) and the Regulations of the Federal Department of Transportation (49 C.F.R., Part 21), issued pursuant to such Act, hereby notifies all bidders that it will affirmatively insure that the contract entered into pursuant to this advertisement will be awarded to the lowest responsible bidder without discrimination on the ground of race, color, or national origin.

NOTICE TO ALL BIDDERS

To report bid rigging activities call: 1-800-424-9071.

The U.S. Department of Transportation (DOT) operates the above toll-free "hotline" Monday through Friday, 8:00 a.m. to 5:00 p.m. eastern time. Anyone with knowledge of possible bid rigging, bidder collusion, or other fraudulent activities should use the "hotline" to report such activities.

The "hotline" is part of the DOT's continuing effort to identify and investigate highway construction contract fraud and abuse and is operated under the direction of the DOT Inspector General. All information will be treated confidentially and caller anonymity will be respected.

FHWA 1273

The requirements of Paragraph VI of FHWA 1273 does not apply to projects with a total cost of less than \$1,000,000.00.

SECOND TIER SUBCONTRACTS

Second Tier subcontracts on federally assisted projects shall be permitted. However, in the case of DBE's, second tier subcontracts will only be permitted where the other subcontractor is also a DBE. All second tier subcontracts shall have the consent of both the Contractor and the Engineer.

DISADVANTAGED BUSINESS ENTERPRISE PROGRAM

It is the policy of the Kentucky Transportation Cabinet ("the Cabinet") that Disadvantaged Business Enterprises ("DBE") shall have the opportunity to participate in the performance of highway construction projects financed in whole or in part by Federal Funds in order to create a level playing field for all businesses who wish to contract with the Cabinet. To that end, the Cabinet will comply with the regulations found in 49 CFR Part 26, and the definitions and requirements contained therein shall be adopted as if set out verbatim herein.

The Cabinet, contractors, subcontractors, and sub-recipients shall not discriminate on the basis of race, color, national origin, or sex in the performance of work performed pursuant to Cabinet contracts. The contractor shall carry out applicable requirements of 49 CFR 26 in the award and administration of federally assisted highway construction projects. The contractor will include this provision in all its subcontracts and supply agreements pertaining to contracts with the Cabinet.

Failure by the contractor to carry out these requirements is a material breach of its contract with the Cabinet, which may result in the termination of the contract or such other remedy as the Cabinet deems necessary.

OBLIGATION OF CONTRACTORS

Each contractor prequalified to perform work on Cabinet projects shall designate and make known to the Cabinet a liaison officer who is assigned the responsibility of effectively administering and promoting an active program for utilization of DBEs.

If a formal goal has not been designated for the contract, all contractors are encouraged to consider DBEs for subcontract work as well as for the supply of material and services needed to perform this work.

Contractors are encouraged to use the services of banks owned and controlled by minorities and women.

CERTIFICATION OF CONTRACT GOAL

Contractors shall include the following certification in bids for projects for which a DBE goal has been established. BIDS SUBMITTED WHICH DO NOT INCLUDE CERTIFICATION OF DBE PARTICIPATION WILL NOT BE READ PUBLICLY. These bids will not be considered for award by the Cabinet and they will be returned to the bidder.

“The bidder certifies that it has secured participation by Disadvantaged Business Enterprises (“DBE”) in the amount of ____ percent of the total value of this contract and that the DBE participation is in compliance with the requirements of 49 CFR 26 and the policies of the Kentucky Transportation Cabinet pertaining to the DBE Program.”

The certification statement is located on the last page of this proposal. All contractors must certify their DBE participation on that page. DBEs utilized in achieving the DBE goal must be certified and prequalified for the work items at the time the bid is submitted.

DBE PARTICIPATION PLAN

All bidders are encouraged to submit their General DBE Participation Plan with their bid on the official form. Lowest responsive bidders whose bid packages include DBE Participation Plans may be awarded the contract at the next Awards Committee meeting provided that the DBE goal is met. The DBE Participation Plan shall include the following:

1. Name and address of DBE Subcontractor(s) and/or supplier(s) intended to be used in the proposed project;
2. Description of the work each is to perform including the work item , unit, quantity, unit price and total amount of the work to be performed by the individual DBE;
3. The dollar value of each proposed DBE subcontract and the percentage of total project contract value this represents. DBE participation may be counted as follows;
 - a) If DBE suppliers and manufactures assume actual and contractual responsibility, the dollar value of materials to be furnished will be counted toward the goal as follows:
 - The entire expenditure paid to a DBE manufacturer;
 - 60 percent of expenditures to DBE suppliers that are not manufacturers provided the supplier is a regular dealer in the product involved. A regular dealer must be engaged in, as its principal business and in its own name, the sale of products to the public, maintain an inventory and own and operate distribution equipment; and
 - the amount of fees or commissions charged by the DBE firms for a bona fide service, such as professional, technical, consultant, or managerial services and assistance in the procurement of essential personnel, facilities, equipment, materials, supplies, delivery of materials and supplies or for furnishing bonds, or insurance, providing such fees or commissions are determined to be reasonable and customary.
 - b) The dollar value of services provided by DBEs such as quality control testing, equipment repair and maintenance, engineering, staking, etc.;
 - c) The dollar value of joint ventures. DBE credit for joint ventures will be limited to the dollar amount of the work actually performed by the DBE in the joint venture;
4. Written and signed documentation of the bidder’s commitment to use a DBE contractor whose participation is being utilized to meet the DBE goal; and

5. Written and signed confirmation from the DBE that it is participating in the contract as provided in the prime contractor's commitment.

The apparent low bidder who does not submit a General DBE Participation Plan with the bid shall submit it within 10 calendar days after receipt of notification that they are the apparent low bidder. The project will not be considered for award prior to submission and approval of the apparent low bidder's DBE Participation Plan.

Detailed DBE Participation Plan forms will be included in the Contractor Package presented to successful bidders following the awarding of the project. The Detailed DBE Participation Plan must be completed and returned to Contract Procurement in accordance with Cabinet policy. A copy of the blank estimate will be included with the Detailed DBE Participation Plan to list sequence items by PCN (Project Control Number).

Changes to DBE Participation Plans must be approved by the Cabinet. The Cabinet may consider extenuating circumstances including, but not limited to, changes in the nature or scope of the project, the inability or unwillingness of a DBE to perform the work in accordance with the bid, and/or other circumstances beyond the control of the prime contractor.

CONSIDERATION OF GOOD FAITH EFFORTS REQUESTS

If the DBE participation submitted in the bid by the apparent lowest responsive bidder does not meet or exceed the DBE contract goal, the apparent lowest responsive bidder must submit a Good Faith Effort Package to satisfy the Cabinet that sufficient good faith efforts were made to meet the contract goals prior to submission of the bid. Efforts to increase the goal after bid submission will not be considered in justifying the good faith effort, unless the contractor can show that the proposed DBE was solicited prior to the letting date. DBEs utilized in achieving the DBE goal must be certified and prequalified for the work items at the time the bid is submitted. One complete set and nine (9) copies of this information must be received in the office of the Division of Contract Procurement no later than 12:00 noon of the tenth calendar day after receipt of notification that they are the apparent low bidder.

Where the information submitted includes repetitious solicitation letters it will be acceptable to submit a sample representative letter along with a distribution list of the firms solicited. Documentation of DBE quotations shall be a part of the good faith effort submittal as necessary to demonstrate compliance with the factors listed below which the Cabinet considers in judging good faith efforts. This documentation may include written subcontractors' quotations, telephone log notations of verbal quotations, or other types of quotation documentation.

The Good Faith Effort Package shall include, but may not be limited to information showing evidence of the following:

1. Whether the bidder attended any pre-bid meetings that were scheduled by the Cabinet to inform DBEs of subcontracting opportunities;
2. Whether the bidder provided solicitations through all reasonable and available means;
3. Whether the bidder provided written notice to all DBEs listed in the DBE directory at the time of the letting who are prequalified in the areas of work that the bidder will be subcontracting;

4. Whether the bidder followed up initial solicitations of interest by contacting DBEs to determine with certainty whether they were interested. If a reasonable amount of DBEs within the targeted districts do not provide an intent to quote or no DBEs are prequalified in the subcontracted areas, the bidder must notify the DBE Liaison in the Office of Minority Affairs to give notification of the bidder's inability to get DBE quotes;
5. Whether the bidder selected portions of the work to be performed by DBEs in order to increase the likelihood of meeting the contract goals. This includes, where appropriate, breaking out contract work items into economically feasible units to facilitate DBE participation, even when the prime contractor might otherwise perform these work items with its own forces;
6. Whether the bidder provided interested DBEs with adequate and timely information about the plans, specifications, and requirements of the contract;
7. Whether the bidder negotiated in good faith with interested DBEs not rejecting them as unqualified without sound reasons based on a thorough investigation of their capabilities. Any rejection should be so noted in writing with a description as to why an agreement could not be reached;
8. Whether quotations were received from interested DBE firms but were rejected as unacceptable without sound reasons why the quotations were considered unacceptable. The fact that the DBE firm's quotation for the work is not the lowest quotation received will not in itself be considered as a sound reason for rejecting the quotation as unacceptable. The fact that the bidder has the ability and/or desire to perform the contract work with its own forces will not be considered a sound reason for rejecting a DBE quote. Nothing in this provision shall be construed to require the bidder to accept unreasonable quotes in order to satisfy DBE goals;
9. Whether the bidder specifically negotiated with subcontractors to assume part of the responsibility to meet the contract DBE goal when the work to be subcontracted includes potential DBE participation;
10. Whether the bidder made any efforts and/or offered assistance to interested DBEs in obtaining the necessary equipment, supplies, materials, insurance and/or bonding to satisfy the work requirements of the bid proposal; and
11. Any other evidence that the bidder submits which may show that the bidder has made reasonable good faith efforts to include DBE participation.

FAILURE TO MEET GOOD FAITH REQUIREMENT

Where the apparent lowest responsive bidder fails to submit sufficient participation by DBE firms to meet the contract goal and upon a determination by the Good Faith Committee based upon the information submitted that the apparent lowest responsive bidder failed to make sufficient reasonable efforts to meet the contract goal, the bidder will be offered the opportunity to meet in person for administrative reconsideration. The bidder will be notified of the Committee's decision within 24 hours of its decision. The bidder will have 24 hours to request reconsideration of the Committee's decision. The reconsideration meeting will be held within two days of the receipt of a request by the bidder for reconsideration.

The request for reconsideration will be heard by the Office of the Secretary. The bidder will have the opportunity to present written documentation or argument concerning the issue of whether it met the goal or made an adequate good faith effort. The bidder will receive a written decision on the reconsideration explaining the basis for the finding that the bidder did or did not meet the goal or made adequate Good Faith efforts to do so.

The result of the reconsideration process is not administratively appealable to the Cabinet or to the United States Department of Transportation.

The Cabinet reserves the right to award the contract to the next lowest responsive bidder or to rebid the contract in the event that the contract is not awarded to the low bidder as the result of a failure to meet the good faith requirement.

SANCTIONS FOR FAILURE TO MEET DBE REQUIREMENTS OF THE PROJECT

Failure by the prime contractor to fulfill the DBE requirements of a project under contract or to demonstrate good faith efforts to meet the goal constitutes a breach of contract. When this occurs, the Cabinet will hold the prime contractor accountable, as would be the case with all other contract provisions. Therefore, the contractor's failure to carry out the DBE contract requirements shall constitute a breach of contract and as such the Cabinet reserves the right to exercise all administrative remedies at its disposal including, but not limited to the following:

- Disallow credit toward the DBE goal;
- Withholding progress payments;
- Withholding payment to the prime in an amount equal to the unmet portion of the contract goal; and/or
- Termination of the contract.

PROMPT PAYMENT

The prime contractor will be required to pay the DBE within seven (7) working days after he or she has received payment from the Kentucky Transportation Cabinet for work performed or materials furnished.

CONTRACTOR REPORTING

All contractors must keep detailed records and provide reports to the Cabinet on their progress in meeting the DBE requirement on any highway contract. These records may include, but shall not be limited to payroll, lease agreements, cancelled payroll checks, executed subcontracting agreements, etc. Prime contractors will be required to submit certified reports on monies paid to each DBE subcontractor or supplier utilized to meet a DBE goal.

Prime contractors will incorporate a requirement into DBE subcontracts, including supply contracts, that DBEs must provide to the Division of Construction, a copy of all checks received from the prime contractor within seven days of receipt of payment for work performed on Cabinet projects. Checks to DBE subcontractors must include the PCN number, estimate number, and the sequence and quantity.

DEFAULT OR DECERTIFICATION OF THE DBE

If the DBE subcontractor or supplier is decertified or defaults in the performance of its work, and the overall goal cannot be credited for the uncompleted work, the prime contractor may utilize a substitute DBE or elect to fulfill the DBE goal with another DBE on a different work item. If after exerting good faith effort in accordance with the Cabinet's Good Faith Effort policies and procedures, the prime contractor is unable to replace the DBE, then the unmet portion of the goal may be waived at the discretion of the Cabinet.

ASPHALT MIXTURE

The rate of application for all asphalt mixtures shall be estimated at 110 lbs/sy per inch of depth, unless otherwise noted.

DGA BASE

The rate of application for DGA Base shall be estimated at 115 lbs/sy per inch of depth.

DGA BASE FOR SHOULDERS

The rate of application shall be estimated at 115 lbs/sy per inch of depth. Payment for necessary grading and/or shaping of existing shoulders prior to placing of Dense Graded Aggregate Base shall be included in the unit price bid per ton for Dense Graded Aggregate Base.

INCIDENTAL SURFACING

The quantities established in the proposal include estimated quantities required for resurfacing or surfacing mailbox turnouts, farm field entrances, residential and commercial entrances, and road and street approaches. These items are to be paved to the limits as shown on Standard Drawing RPM 110 or to the limits as directed by the Engineer. In the event signal detectors are present in the intersecting streets or roads, the paving of the crossroads shall be to the right of way limit or back of the signal detector, whichever is the farthest back of the mainline. These areas are to be surfaced or resurfaced as directed by the Engineer and no direct payment will be allowed for placing and compacting.

FUEL AND ASPHALT PAY ADJUSTMENT

These contract items Lot Pay Adjustment, Asphalt Adjustment and Fuel Adjustment, are for possible future payments. Additional monies may need to be setup with an additional change order if existing contract amount is insufficient to pay all items on the contract. Unit price is \$1.00. Quantity will be actual adjustment after work is completed.

OPTION B

The Contractor is advised that the compaction of asphalt mixtures furnished to this project will be accepted by OPTION B in accordance with Section 402 and Section 403 of the *2004 Standard Specification*.

SPECIAL NOTE FOR PROJECT IDENTIFICATION SIGNS

When directed by the Engineer, install Project Identification Signs furnished by the Department at each end of the project. The signs furnished by the Department will be approximately 44" X 72" or 72" X 120" aluminum sign blanks with standard color reflective sheeting with the applicable county and project names affixed. The Engineer will determine the size and location of the signs, if any, to be used on the project(s) at the time of construction.

Pick up the signs to be furnished by the Department at the District Traffic Operations Facility. Furnish posts and hardware for mounting the signs. Install the signs at locations determined by the Engineer. Maintain the signs during the duration of the project. Upon completion of the work, remove the signs and return them to District Traffic Operations Facility. Retain possession of the posts and hardware.

The Department will measure installation of the Project Identification Signs in individual units, Each. Payment at the contract unit price Each shall be full compensation for all labor, materials, equipment, and incidentals required for picking up, installing, maintaining, and returning the project identification signs furnished by the Department.

<u>Code</u>	<u>Pay Item</u>	<u>Pay Unit</u>
20588NC	Install Project Identification Signs	Each

SPECIAL PROVISION FOR WASTE AND BORROW SITES

The contractor is advised that it is their responsibility to gain U.S. Army Corp of Engineer's approval before utilizing a waste or borrow site that involves "Waters of the United States". "Waters of the United States" are defined as perennial or intermittent streams, ponds or wetlands. Ephemeral streams are also considered jurisdictional waters, and are typically dry except during rainfall, but have a defined drainage channel. Questions concerning any potential impacts to "Waters..." should be brought to the attention of the appropriate District Office for the Corps of Engineers for a determination, prior to disturbance. Any fees associated with obtaining approval from the U.S. Army Corp of Engineer or other appropriate regulatory agencies for waste and borrow sites is the responsibility of the contractor.

This form must be completed and submitted to FHWA with the PS&E package for federal-aid funded Interstate, Appalachia, and Mega projects. This form shall also be submitted to FHWA for **all** federal-aid projects that fall under conditions No. 2 & 3 outlined elsewhere in this form. For all other federal-aid projects, this form shall be completed and retained in the KYTC project file.

Date: January 29, 2006

Project #: MARS 73504 01R

County: CHRISTIAN

Item #: 2-1060.00

Federal #: BRZ 0203(287)

Letting

Date: March 23, 2007

Projects that require NO new or additional right-of-way acquisitions and/or relocations

The proposed transportation improvement will be built within the existing rights-of-way and there are no properties to be acquired, individuals and families ("relocatees") to be relocated, or improvements to be removed as a part of this project.

Projects that require new or additional right-of-way acquisitions and/or relocations

Per 23 CFR 635.309, the KYTC hereby certify that all relocatees have been relocated to decent, safe, and sanitary housing or that KYTC has made available to relocatees adequate replacement housing in accordance with the provisions of the current FHWA directive(s) covering the administration of the Highway Relocation Assistance Program **and** that at least one of the following three conditions has been met. **(Check those that apply.)**

1. All necessary rights-of-way, including control of access rights when applicable, have been acquired including legal and physical possession. Trial or appeal of cases may be pending in court but legal possession has been obtained. There may be some improvements remaining on the right-of-way, but all occupants have vacated the lands and improvements, and KYTC has physical possession and the rights to remove, salvage, or demolish these improvements and enter on all land. **Fair market value has been paid or deposited with the court.**
2. Although all necessary rights-of-way have not been fully acquired, the right to occupy and to use all rights-of-way required for the proper execution of the project has been acquired. Trial or appeal of some parcels may be pending in court and on other parcels full legal possession has not been obtained, but right of entry has been obtained, the occupants of all lands and improvements have vacated, and KYTC has physical possession and right to remove, salvage, or demolish these improvements. **Fair market value has been paid or deposited with the court for most parcels. Fair market value for all pending parcels will be paid or deposited with the court prior to start of construction. (See note.)**

3. The acquisition or right of occupancy and use of a **few** remaining parcels are not complete and/or some parcels still have occupants. However, all remaining occupants have had replacement housing made available to them in accordance with 49 CFR 24.204. The KYTC is hereby requesting authorization to advertise this project for bids and to proceed with physical construction even though the necessary rights-of-way will not be fully acquired, and/or some occupants will not be relocated, and/or the fair market value will not be paid or deposited with the court for some parcels at the start of construction. KYTC will fully meet all the requirements outlined in 23 CFR 309(c) (3) and 49 CFR 102(j) and will expedite completion of all acquisitions, relocations, and full payments after construction starts. A full explanation and reason for this request, including identification of each such parcel and dates on which acquisitions, payments, and relocations will be completed, is attached to this certification form for FHWA consideration of approval. **(See note.)**

Note: The KYTC may request authorization on this basis only in unique and unusual circumstances. Proceeding to construction of projects on this basis shall be the exception and never become the rule. In all FHWA-approved cases, the KYTC shall make extraordinary efforts to expedite completion of the acquisition, payment for all affected parcels, and the relocation of all relocatees promptly after start of construction.

Approved: Everett T. Green _____ District ROW Supervisor
Printed Name Approved

Approved: Elsworth Turner 01-29-07 _____ Director of ROW &
Utilities or Designee
Printed Name Approved



1/29/2007

Approved: _____ FHWA, Right-of-Way
Officer

Printed Name

Approved

Date: January 29,
2007

Project #: MARS 73504 01 R County: CHRISTIAN
Item #: 2-1060.00 Federal #: BRZ 0203(287)

Letting

Date: March 23, 2007

This project has 3 total number of parcels to be acquired, and 0 total number of individual or families to be relocated, as well as 0 total number of businesses to be relocated.

- 3 Parcels where acquired by a signed fee simple deed and fair market value has been paid
- _____ Parcels have been acquired by IOJ through condemnation and fair market value has been deposited with the court
- _____ Parcels have not been acquired at this time (*explain below for each parcel*)
- _____ Parcels have been acquired or have a "right of entry" but fair market value has not been paid or has not been deposited with the court (*explain below for each parcel*)
- _____ Relocatees have not been relocated from _____ and _____ parcels: (*explain below for each parcel*)

Parcel #	Name/Station	Explanation for delayed acquisition, delayed relocation, or delayed payment of fair market value	Proposed date of payment or of relocation

There are 0 billboards and/or 0 cemeteries involved on this project.
water or monitoring wells on

There are 0 parcels _____ and _____. All
have been acquired and are the responsibility of the project contractor to close/cap.

**UTILITY NOTES TO BE INCLUDED IN THE PROPOSAL
SPECIAL NOTES FOR UTILITY CLEARANCE
IMPACT ON CONSTRUCTION**

**Christian County, BRZ 0203 (287)
FD52 024 73504 01U
Replace Bridge Over West Fork Of Pond River
Item No. 2-1060.00**

The following is a list of utility companies involved on this project. Contractor is advised to use caution and call **BUD** prior to beginning work.

There are no known utilities that will be impacted by this project.

PROTECTION OF UTILITIES

The location of utilities provided in the contract documents has been furnished by the facility owners and/or by reviewing record drawings and may not be accurate. It will be the roadway contractor's responsibility to locate utilities before excavating by calling the various utility owners and by examining any supplemental information supplied by the cabinet. If necessary, the roadway contractor shall determine the exact location and elevation of utilities by hand digging to expose utilities before excavating in the area of a utility. The cost of repair and any other associated costs for any damage to utilities caused by the roadway contractor's operations shall be borne by the roadway contractor.

The contractor is advised to contact the **BUD one-call system at 1-800-752-6007** at least two working days prior to excavating. Contractor should be aware that owners of underground facilities are not required to be members of the BUD one-call system. It may be necessary for the contractor to contact the County Court Clerk to determine what utility companies have facilities in the project area.

N O T I C E

**DEPARTMENT OF THE ARMY
CORPS OF ENGINEERS
(NATIONWIDE PERMIT AUTHORIZATION)**

PROJECT: Christian County (CR-1002), Item No. 2-1060.00
Replace Bridge & Approaches over West Fork of Pond River

The Section 404 activities for this project have been previously permitted under the authority of the Department of the Army Nationwide Permit No. 14 "Linear Transportation Crossings". In order for this authorization to be valid, the attached conditions must be followed. The contractor shall post a copy of this Nationwide Permit in a conspicuous location at the project site for the duration of construction and comply with the general conditions as required.

To more readily expedite construction, the contractor may elect to alter the design or perform the work in a manner different from what was originally proposed and specified. Prior to commencing such alternative work, the contractor shall obtain **written** permission from the Division of Construction and the Corps of Engineers. A copy of any request to the Corps of Engineers to alter this proposal and subsequent responses shall be forwarded to the Division of Environmental Analysis, DA Permit Coordinator, for office records and for informational purposes.



DEPARTMENT OF THE ARMY
U.S. ARMY ENGINEER DISTRICT, LOUISVILLE
CORPS OF ENGINEERS
NEWBURGH REGULATORY OFFICE
P.O. Box 489
NEWBURGH, INDIANA 47629-0489
FAX: (812) 858-2678
<http://www.lrl.usace.army.mil>

April 27, 2006

Operations Division
Regulatory Branch (South)
ID No. 200600253-jmb

Commonwealth of Kentucky Transportation Cabinet
Department of Highways
200 Mero Street
Frankfort, Kentucky 40622

Dear Sir or Madam:

This is in response to your request for authorization to replace an existing 76 foot long single span metal bridge, and approaches, with a 84 foot long pre-cast concrete bridge on County Road 1078 (JP Grace Road) over the West Fork of Pond River. In addition, there will be 81.1 cubic yards (0.04 acres) of fill material, clean limestone rip rap, placed below the ordinary high water mark of the West Fork of Pond River for bank stabilization and structural protection of the new bridge. The project is located approximately 3.5 miles south of White Plains, Christian County, Kentucky. The information supplied by you was reviewed to determine whether a Department of the Army (DA) permit will be required under the provisions of Section 404 of the Clean Water Act.

Your project is considered a discharge of backfill or bedding material for a road crossing. The project is authorized under the provisions of 33 CFR 330 A Nationwide Permit (NWP) No. 14, Linear Transportation Crossings, as published in the Federal Register January 15, 2002. Under the provisions of this authorization you must comply with the enclosed:

1. Terms for Nationwide Permit No. 14;
2. Nationwide Permit General Conditions; and
3. Water Quality Certification (WQC) Conditions for Nationwide Permit No. 14 dated March 17, 2002, issued by the Kentucky Division of Water.

Once you obtain your certification, or if no application was required, you may proceed with the work without further contact or verification from us. The enclosed Compliance Certification should be signed and returned when the project is completed. This verification is valid until the Nationwide Permit (NWP) is modified, reissued, or revoked. All of the existing NWPs are scheduled to be modified, reissued, or revoked prior to March 18, 2007. It is incumbent upon you to remain informed of changes to the NWPs. We will issue a public notice when the NWPs are reissued. Furthermore, if you commence or are under contract to commence this activity before the date that the relevant

nationwide permit is modified or revoked, you will have twelve (12) months from the date of the modification or revocation of the NWP to complete the activity under the present terms and conditions of this Nationwide Permit. A copy of this letter is being sent to your agent and the Kentucky Division of Water.

If you have any questions, please contact Jarrod Bonnick by writing to the above address, ATTN: CELRL-OP-FS, or by calling (812) 853-9715. Any correspondence on this matter should refer to our ID No. 200600253-jmb.

Sincerely,

ORIGINAL SIGNED

Michael Ricketts
Project Manager
Regulatory Branch
COPY

Copy Furnished:

ADDRESS FOR COORDINATING AGENCY

Mr. David Morgan
Director
Division of Water
Natural Resources and Environmental Protection Cabinet
14 Reilly Road
Frankfort, Kentucky 40601

ADDRESS FOR AUTHORIZED AGENT

✓ Mr. Ronald Rigney II
Permit Coordinator
Division of Environmental Analysis
200 Mero Street
Frankfort, Kentucky 40622

TERMS FOR NATIONWIDE PERMIT NO. 14
Linear Transportation Projects

Activities required for the construction, expansion, modification, or improvement of linear transportation crossings (e.g., highways, railways, trails, airport runways, and taxiways) in waters of the US, including wetlands, if the activity meets the following criteria:

a. This NWP is subject to the following acreage limits:

(1) For linear transportation projects in non-tidal waters, provided the discharge does not cause the loss of greater than 1/2-acre of waters of the US; or

(2) For linear transportation projects in tidal waters, provided the discharge does not cause the loss of greater than 1/3-acre of waters of the US.

b. The permittee must notify the District Engineer in accordance with General Condition 13 if any of the following criteria are met:

(1) The discharge causes the loss of greater than 1/10-acre of waters of the US; or

(2) There is a discharge in a special aquatic site, including wetlands;

c. The notification must include a compensatory mitigation proposal to offset permanent losses of waters of the US to ensure that those losses result only in minimal adverse effects to the aquatic environment and a statement describing how temporary losses will be minimized to the maximum extent practicable;

d. For discharges in special aquatic sites, including wetlands, and stream riffle and pool complexes, the notification must include a delineation of the affected special aquatic sites;

e. The width of the fill is limited to the minimum necessary for the crossing;

f. This permit does not authorize stream channelization, and the authorized activities must not cause more than minimal changes to the hydraulic flow characteristics of the stream, increase flooding, or cause more than minimal degradation of water quality of any stream (see General Conditions 9 and 21);

g. This permit cannot be used to authorize non-linear features commonly associated with transportation projects, such as vehicle maintenance or storage buildings, parking lots, train stations, or aircraft hangars; and

h. The crossing is a single and complete project for crossing waters of the US. Where a road segment (i.e., the shortest segment of a road with independent utility that is part of a larger project) has multiple crossings of streams (several single and complete projects) the Corps will consider whether it should use its discretionary authority to require an Individual Permit. (Sections 10 and 404)

Note: Some discharges for the construction of farm roads, forest roads, or temporary roads for moving mining equipment may be eligible for an exemption from the need for a Section 404 permit (see 33 CFR 323.4).

General Conditions: The following general conditions must be followed in order for any authorization by a NWP to be valid:

1. **Navigation.** No activity may cause more than a minimal adverse effect on navigation.
2. **Proper Maintenance.** Any structure or fill authorized shall be properly maintained, including maintenance to ensure public safety.
3. **Soil Erosion and Sediment Controls.** Appropriate soil erosion and sediment controls must be used and maintained in effective operating condition during construction, and all exposed soil and other fills, as well as any work below the ordinary high water mark or high tide line, must be permanently stabilized at the earliest practicable date. Permittees are encouraged to perform work within waters of the United States during periods of low-flow or no-flow.
4. **Aquatic Life Movements.** No activity may substantially disrupt the life-cycle movements of those species of aquatic life indigenous to the waterbody, including those species that normally migrate through the area, unless the activity's primary purpose is to impound water. Culverts placed in streams must be installed to maintain low flow conditions.
5. **Equipment.** Heavy equipment working in wetlands must be placed on mats, or other measures must be taken to minimize soil disturbance.
6. **Regional and Case-By-Case Conditions.** The activity must comply with any regional conditions, which may have been added by the Division Engineer (see 33 CFR 330.4(e)) and with any case specific conditions added by the Corps or by the state or tribe in its Section 401 Water Quality Certification and Coastal Zone Management Act consistency determination.
7. **Wild and Scenic Rivers.** No activity may occur in a component of the National Wild and Scenic River System; or in a river officially designated by Congress as a "study river" for possible mix inclusion in the system, while the river is in an official study status; unless the appropriate Federal agency, with direct management responsibility for such river, has determined in writing that the proposed activity will not adversely affect the Wild and Scenic River designation, or study status. Information on Wild and Scenic Rivers may be obtained from the appropriate Federal land management agency in the area (e.g., National Park Service, US Forest Service, Bureau of Land Management, US Fish and Wildlife Service).
8. **Tribal Rights.** No activity or its operation may impair reserved tribal rights, including, but not limited to, reserved water rights and treaty fishing and hunting rights.
9. **Water Quality.** (a) In certain States and tribal lands an individual 401 water quality certification must be obtained or waived (See 33 CFR 330.4(c)).
(b) For NWPs 12, 14, 17, 18, 32, 39, 40, 42, 43, and 44, where the State or tribal 401 certification (either generically or individually) does not require or approve a water quality management measures, the permittee must provide water quality management measures that will ensure that the authorized work does not result in more than minimal degradation of water quality (or the Corps determines that compliance with state or local standards, where applicable, will ensure no more than minimal adverse effect on water quality). An important component of a water quality management plan includes stormwater management that minimizes degradation of the downstream aquatic system, including water quality (Refer to General Condition 21 for stormwater management requirements). Another important component of a water quality management plan is the establishment and maintenance of vegetated buffers next to open waters, including streams (Refer to General Condition 19 for vegetated buffer requirements for the NWPs). This condition is only applicable to projects that have the potential to affect water quality. While appropriate measures must be taken, in most cases it is not necessary to conduct detailed studies to identify such measures or to require monitoring.
10. **Coastal Zone Management.** In certain states, an individual state coastal zone management consistency concurrence must be obtained or waived (see 33 CFR 330.4(d)).
11. **Endangered Species.** (a) No activity is authorized under any NWP, which is likely to jeopardize the continued existence of a threatened or endangered species, or a species proposed for such designation, as identified under the Federal Endangered Species Act, or which will destroy or adversely modify the critical habitat of such species. Non-federal permittees shall notify the District Engineer if any listed species or designated critical habitat might be affected or is in the vicinity of the project, or is located in the designated critical habitat and shall not begin work on the activity until notified by the District Engineer that the requirements of the Endangered Species Act have been satisfied and that the activity is authorized. For activities that may affect Federally-listed endangered or threatened species or designated critical habitat, the notification must include the name(s) of the endangered or threatened species that may be affected by the proposed work or that utilize the designated critical habitat that may be affected by the proposed work. As a result of formal or informal consultation with the FWS or NMFS, the District Engineer may add species-specific regional endangered

(b) Authorization of an activity by a nationwide permit does not authorize the 'take' of a threatened or endangered species as defined under the Federal Endangered Species Act. In the absence of separate authorization (e.g., an ESA Section 10 Permit, a Biological Opinion with 'incidental take' provisions, etc.) from the US Fish and Wildlife Service or the National Marine Fisheries Service, both lethal and non-lethal 'takes' of protected species are in violation of the Endangered Species Act. Information on the location of threatened and endangered species and their critical habitat can be obtained directly from the offices of the US Fish and Wildlife Service and National Marine Fisheries Service or their World Wide Web pages at <http://www.fws.gov/r9endspp/endspp.html> and http://www.nfms.noaa.gov/prot__res/overview/es.html, respectively.

12. Historic Properties. No activity, which may affect historic properties, listed, or eligible for listing, in the National Register of Historic Places is authorized, until the DE has complied with the provisions of 33 CFR part 325, Appendix C. The prospective permittee must notify the District Engineer if the authorized activity may affect any historic properties listed, determined to be eligible, or which the prospective permittee has reason to believe may be eligible for listing on the National Register of Historic Places, and shall not begin the activity until notified by the District Engineer that the requirements of the National Historic Preservation Act have been satisfied and that the activity is authorized. Information on the location and existence of historic resources can be obtained from the State Historic Preservation Office and the National Register of Historic Places (see 33 CFR 330.4(g)). For activities that may affect historic properties listed in, or eligible for listing in, the National Register of Historic Places, the notification must state which historic property may be affected by the proposed work or include a vicinity map indicating the location of the historic property.

13. Notification. (a) **Timing:** Where required by the terms of the NWP, the prospective permittee must notify the District Engineer with a preconstruction notification (PCN) as early as possible. The District Engineer must determine if the PCN is complete within 30 days of the date of receipt and can request the additional information necessary to make the PCN complete only once. However, if the prospective permittee does not provide all of the requested information, then the District Engineer will notify the prospective permittee that the PCN is still incomplete and the PCN review process will not commence until all of the requested information has been received by the District Engineer. The prospective permittee shall not begin the activity:

(1) Until notified in writing by the District Engineer that the activity may proceed under the NWP with any special conditions imposed by the District or Division Engineer; or

(2) If notified in writing by the District or Division Engineer that an individual permit is required; or

(3) Unless 45 days have passed from the District Engineer's receipt of the complete notification and the prospective permittee has not received written notice from the District or Division Engineer. Subsequently, the permittee's right to proceed under the NWP may be modified, suspended, or revoked only in accordance with the procedure set forth in 33 CFR 330.5(d)(2).

(b) **Contents of Notification:** The notification must be in writing and include the following information:

(1) Name, address, and telephone numbers of the prospective permittee;

(2) Location of the proposed project;

(3) Brief description of the proposed project; the project's purpose; direct and indirect adverse environmental effects the project would cause; any other NWP(s), regional general permit(s), or individual permit(s) Used or intended to be Used to authorize any part of the proposed project or any related activity. Sketches should be provided when necessary to show that the activity complies with the terms of the NWP (Sketches usually clarify the project and when provided result in a quicker decision); and

(4) For NWPs 7, 12, 14, 18, 21, 34, 38, 39, 40, 41, 42, and 43, the PCN must also include a delineation of affected special aquatic sites, including wetlands, vegetated shallows (e.g., submerged aquatic vegetation, seagrass beds), and riffle and pool complexes (see paragraph 13(f));

(5) For NWP 7, Outfall Structures and Maintenance, the PCN must include information regarding the original design capacities and configurations of those areas of the facility where maintenance dredging or excavation is proposed.

(6) For NWP 14, Linear Transportation Projects, the PCN must include a compensatory mitigation proposal to offset permanent losses of waters of the US and a statement describing how temporary losses of waters of the US will be minimized to the maximum extent practicable.

(7) For NWP 21, Surface Coal Mining Activities, the PCN must include an Office of Surface Mining (OSM) or state-approved mitigation plan. To be authorized by this NWP, the District Engineer must determine that the activity complies with the terms and conditions of the NWP and that the adverse environmental effects are minimal both individually and cumulatively and must notify the project sponsor of this determination in writing;

(8) For NWP 27, Stream and Wetland Restoration Activities, the PCN must include documentation of the prior condition of the site that will be reverted by the permittee.

(9) For NWP 29, Single-Family Housing, the PCN must also include:

(i) Any past use of this NWP by the individual permittee and/or the permittee's spouse;

(ii) A statement that the single-family housing activity is for a personal residence of the permittee;

(iii) A description of the entire parcel, including its size, and a delineation of wetlands. For the purpose of this NWP, parcels of land measuring 1/4 acre or less will not require a formal on-site delineation. However, the applicant shall provide an indication of where the wetlands are and the amount of wetlands that exists on the property. For parcels greater than 1/4 acre in size, a formal wetland delineation must be prepared in accordance with the current method required by the Corps. (See paragraph 13(f));

(iv) A written description of all land (including, if available, legal descriptions) owned by the prospective permittee and/or the

partner, corporation, joint tenant, co-tenant, or as a tenant-by-the-entirety) and any land on which a purchase and sale agreement or other contract for sale or purchase has been executed;

(10) For NWP 31, Maintenance of Existing Flood Control Facilities, the prospective permittee must either notify the District Engineer with a PCN prior to each maintenance activity or submit a five year (or less) maintenance plan. In addition, the PCN must include all of the following:

(i) Sufficient baseline information so as to identify the approved channel depths and configurations and existing facilities. Minor deviations are authorized, provided the approved flood control protection or drainage is not increased;

(ii) A delineation of any affected special aquatic sites, including wetlands; and,

(iii) Location of the dredged material disposal site.

(11) For NWP 33, Temporary Construction, Access, and Dewatering, the PCN must also include a restoration plan of reasonable measures to avoid and minimize adverse effects to aquatic resources.

(12) For NWP's 39, 43, and 44, the PCN must also include a written statement to the District Engineer explaining how avoidance and minimization of losses of waters of the US were achieved on the project site.

(13) For NWP 39 and NWP 42, the PCN must include a compensatory mitigation proposal that offsets unavoidable losses of waters of the US or justification explaining why compensatory mitigation should not be required. For discharges that cause the loss of greater than 300 linear feet of an intermittent stream bed, to be authorized, the District Engineer must determine that the activity complies with the other terms and conditions of the NWP, determine adverse environmental effects are minimal both individually and cumulatively, and waive the limitation on stream impacts in writing before the permittee may proceed;

(14) For NWP 40 (Agricultural Activities), the PCN must include a compensatory mitigation proposal to offset losses of waters of the US. This NWP does not authorize the relocation of greater than 300 linear-feet of existing serviceable drainage ditches constructed in non-tidal streams unless, for drainage ditches constructed in intermittent non-tidal streams, the District Engineer waives this criterion in writing, and the District Engineer has determined that the project complies with all terms and conditions of this NWP, and that any adverse impacts of the project on the aquatic environment are minimal, both individually and cumulatively;

(15) For NWP 43 (Stormwater Management Facilities), the PCN must include, for the construction of new stormwater management facilities, a maintenance plan (in accordance with state and local requirements, if applicable) and a compensatory mitigation proposal to offset losses of waters of the US. For discharges that cause the loss of greater than 300 linear feet of an intermittent streambed, to be authorized, the District Engineer must determine that the activity complies with the other terms and conditions of the NWP, determine adverse environmental effects are minimal both individually and cumulatively, and waive the limitation on stream impacts in writing before the permittee may proceed;

(16) For NWP 44, Mining Activities, the PCN must include a description of all waters of the US adversely affected by the project, a description of measures taken to minimize adverse effects to waters of the US, a description of measures taken to comply with the criteria of the NWP, and a reclamation plan (for aggregate mining activities in isolated waters and non-tidal wetlands adjacent to headwaters and any hard rock/mineral mining activities).

(17) For activities that may adversely affect Federally-listed endangered or threatened species, the PCN must include the name(s) of those endangered or threatened species that may be affected by the proposed work or utilize the designated critical habitat that may be affected by the proposed work.

(18) For activities that may affect historic properties listed in, or eligible for listing in, the National Register of Historic Places, the PCN must state which historic property may be affected by the proposed work or include vicinity map indicating the location of the historic property.

(c) Form of Notification: The standard individual permit application form (Form ENG 4345) may be Used as the notification but must clearly indicate that it is a PCN and must include all of the information required in (b) (1)-(19) of General Condition 13. A letter containing the requisite information may also be used.

(d) District Engineer's Decision: In reviewing the PCN for the proposed activity, the District Engineer will determine whether the activity authorized by the NWP will result in more than minimal individual or cumulative adverse environmental effects or may be contrary to the public interest. The prospective permittee may, optionally, submit a proposed mitigation plan with the PCN to expedite the process and the District Engineer will consider any proposed compensatory mitigation the applicant has included in the proposal in determining whether the net adverse environmental effects to the aquatic environment of the proposed work are minimal. If the District Engineer determines that the activity complies with the terms and conditions of the NWP and that the adverse effects on the aquatic environment are minimal, the District Engineer will notify the permittee and include any conditions the District Engineer deems necessary. Any compensatory mitigation proposal must be approved by the District Engineer prior to commencing work. If the prospective permittee is required to submit a compensatory mitigation proposal with the PCN, the proposal may be either conceptual or detailed. If the prospective permittee elects to submit a compensatory mitigation plan with the PCN, the District Engineer will expeditiously review the proposed compensatory mitigation plan. The District Engineer must review the plan within 45 days of receiving a complete PCN and determine whether the conceptual or specific proposed mitigation would ensure no more than minimal adverse effects on the aquatic environment. If the net adverse effects of the project on the aquatic environment (after consideration of the compensatory mitigation proposal) are determined by the District Engineer to be minimal, the District Engineer will provide a timely written response to the applicant stating that the project can proceed under the terms and conditions of the nationwide permit. If the District Engineer determines that the adverse effects of the proposed work are more than minimal, then he will notify the applicant either: (1) That the project does not qualify for authorization under the NWP and instruct the applicant on the procedures to seek

mitigation proposal that would reduce the adverse effects on the aquatic environment to the minimal level; or (3) that the project is authorized under the NWP with specific modifications or conditions. Where the District Engineer determines that mitigation is required in order to ensure no more than minimal adverse effects on the aquatic environment, the activity will be authorized within the 45-day PCN period, including the necessary conceptual or specific mitigation or a requirement that the applicant submit a mitigation proposal that would reduce the adverse effects on the aquatic environment to the minimal level. When conceptual mitigation is included, or a mitigation plan is required under item (2) above, no work in waters of the US will occur until the District Engineer has approved a specific mitigation plan.

(e) Agency Coordination: The District Engineer will consider any comments from Federal and State agencies concerning the proposed activity's compliance with the terms and conditions of the NWPs and the need for mitigation to reduce the project's adverse effects on the aquatic environment to a minimal level.

For activities requiring notification to the District Engineer that result in the loss of greater than 1/2 acre of waters of the US, the District Engineer will, upon receipt of a notification, provide immediately (e.g., via facsimile transmission, overnight mail, or other expeditious manner), a copy to the appropriate offices of the Fish and Wildlife Service, State natural resource or water quality agency, EPA, State Historic Preservation Officer (SHPO), and, if appropriate, the National Marine Fisheries Service. With the exception of NWP 37, these agencies will then have 10 calendar days from the date the material is transmitted to telephone or fax the District Engineer notice that they intend to provide substantive, site-specific comments. If so contacted by an agency, the District Engineer will wait an additional 15 calendar days before making a decision on the notification. The District Engineer will fully consider agency comments received within the specified time frame, but will provide no response to the resource agency, except as provided below. The District Engineer will indicate in the administrative record associated with each notification that the resource agencies' concerns were considered. As required by Section 305(b)(4)(B) of the Magnuson-Stevens Fishery Conservation and Management Act, the District Engineer will provide a response to National Marine Fisheries Service within 30 days of receipt of any Essential Fish Habitat conservation recommendations. Applicants are encouraged to provide the Corps multiple copies of notifications to expedite agency notification.

(f) Wetlands Delineations: Wetland delineations must be prepared in accordance with the current method required by the Corps. For NWP 29 see paragraph (b)(9)(iii) for parcels less than 1/4 acre in size. The permittee may ask the Corps to delineate the special aquatic site. There may be some delay if the Corps does the delineation. Furthermore, the 45-day period will not start until the wetland delineation has been completed and submitted to the Corps, where appropriate.

14. Compliance Certification. Every permittee who has received a nationwide permit verification from the Corps will submit a signed certification regarding the completed work and any required mitigation. The certification will be forwarded by the Corps with the authorization letter. The certification will include: (a) A statement that the authorized work was done in accordance with the Corps authorization, including any general or specific conditions; (b) A statement that any required mitigation was completed in accordance with the permit conditions; and (c) The signature of the permittee certifying the completion of the work and mitigation.

15. Use of Multiple Nationwide Permits. The use of more than one NWP for a single and complete project is prohibited, except when the acreage loss of waters of the US authorized by the NWPs does not exceed the acreage limit of the NWP with the highest specified acreage limit. For example, if a road crossing over tidal waters is constructed under NWP 14, with associated bank stabilization authorized by NWP 13, the maximum acreage loss of waters of the US for the total project cannot exceed 1/3 acre.

16. Water Supply Intakes. No activity, including structures and work in navigable waters of the US or discharges of dredged or fill material, may occur in the proximity of a public water supply intake except where the activity is for repair of the public water supply intake structures or adjacent bank stabilization.

17. Shellfish Beds. No activity, including structures and work in navigable waters of the US or discharges of dredged or fill material, may occur in areas of concentrated shellfish populations, unless the activity is directly related to a shellfish harvesting activity authorized by NWP 4.

18. Suitable Material. No activity, including structures and work in navigable waters of the US or discharges of dredged or fill material, may consist of unsuitable material (e.g., trash, debris, car bodies, asphalt, etc.) and material Used for construction or discharged must be free from toxic pollutants in toxic amounts (see Section 307 of the Clean Water Act).

19. Mitigation. The District Engineer will consider the factors discussed below when determining the acceptability of appropriate and practicable mitigation necessary to offset adverse effects on the aquatic environment that are more than minimal.

(a) The project must be designed and constructed to avoid and minimize adverse effects to waters of the US to the maximum extent practicable at the project site (i.e., on site).

(b) Mitigation in all its forms (avoiding, minimizing, rectifying, reducing or compensating) will be required to the extent necessary to ensure that the adverse effects to the aquatic environment are minimal.

(c) Compensatory mitigation at a minimum one-for-one ratio will be required for all wetland impacts requiring a PCN, unless the District

(d) Compensatory mitigation (i.e., replacement or substitution of aquatic resources for those impacted) will not be used to increase the acreage losses allowed by the acreage limits of some of the NWP. For example, 1/4 -acre of wetlands cannot be created to change a 3/4 -acre loss of wetlands to a 1/2 -acre loss associated with NWP 39 verification. However, 1/2 -acre of created wetlands can be used to reduce the impacts of a 1/2 -acre loss of wetlands to the minimum impact level in order to meet the minimal impact requirement associated with NWPs.

(e) To be practicable, the mitigation must be available and capable of being done considering costs, existing technology, and logistics in light of the overall project purposes. Examples of mitigation that may be appropriate and practicable include, but are not limited to: reducing the size of the project; establishing and maintaining wetland or upland vegetated buffers to protect open waters such as streams; and replacing losses of aquatic resource functions and values by creating, restoring, enhancing, or preserving similar functions and values, preferably in the same watershed.

(f) Compensatory mitigation plans for projects in or near streams or other open waters will normally include a requirement for the establishment, maintenance, and legal protection (e.g., easements, deed restrictions) of vegetated buffers to open waters. In many cases, vegetated buffers will be the only compensatory mitigation required. Vegetated buffers should consist of native species. The width of the vegetated buffers required will address documented water quality or aquatic habitat loss concerns. Normally, the vegetated buffer will be 25 to 50 feet wide on each side of the stream, but the District Engineers may require slightly wider vegetated buffers to address documented water quality or habitat loss concerns. Where both wetlands and open waters exist on the project site, the Corps will determine the appropriate compensatory mitigation (e.g., stream buffers or wetlands compensation) based on what is best for the aquatic environment on a watershed basis. In cases where vegetated buffers are determined to be the most appropriate form of compensatory mitigation, the District Engineer may waive or reduce the requirement to provide wetland compensatory mitigation for wetland impacts.

(g) Compensatory mitigation proposals submitted with the "notification" may be either conceptual or detailed. If conceptual plans are approved under the verification, then the Corps will condition the verification to require detailed plans be submitted and approved by the Corps prior to construction of the authorized activity in waters of the US.

(h) Permittees may propose the use of mitigation banks, in-lieu fee arrangements or separate activity-specific compensatory mitigation. In all cases that require compensatory mitigation, the mitigation provisions will specify the party responsible for accomplishing and/or complying with the mitigation plan.

20. Spawning Areas. Activities, including structures and work in navigable waters of the US or discharges of dredged or fill material, in spawning areas during spawning seasons must be avoided to the maximum extent practicable. Activities that result in the physical destruction (e.g., excavate, fill, or smother downstream by substantial turbidity) of an important spawning area are not authorized.

21. Management of Water Flows. To the maximum extent practicable, the activity must be designed to maintain preconstruction downstream flow conditions (e.g., location, capacity, and flow rates). Furthermore, the activity must not permanently restrict or impede the passage of normal or expected high flows (unless the primary purpose of the fill is to impound waters) and the structure or discharge of dredged or fill material must withstand expected high flows. The activity must, to the maximum extent practicable, provide for retaining excess flows from the site, provide for maintaining surface flow rates from the site similar to preconstruction conditions, and provide for not increasing water flows from the project site, relocating water, or redirecting water flow beyond preconstruction conditions. Stream channelizing will be reduced to the minimal amount necessary, and the activity must, to the maximum extent practicable, reduce adverse effects such as flooding or erosion downstream and upstream of the project site, unless the activity is part of a larger system designed to manage water flows. In most cases, it will not be a requirement to conduct detailed studies and monitoring of water flow.

This condition is only applicable to projects that have the potential to affect waterflows. While appropriate measures must be taken, it is not necessary to conduct detailed studies to identify such measures or require monitoring to ensure their effectiveness. Normally, the Corps will defer to state and local authorities regarding management of water flow.

22. Adverse Effects From Impoundments. If the activity, including structures and work in navigable waters of the US or discharge of dredged or fill material, creates an impoundment of water, adverse effects on the aquatic system caused by the accelerated passage of water and/or the restriction of its flow shall be minimized to the maximum extent practicable.

23. Waterfowl Breeding Areas. Activities, including structures and work in navigable waters of the US or discharges of dredged or fill material, into breeding areas for migratory waterfowl must be avoided to the maximum extent practicable.

24. Removal of Temporary Fills. Any temporary fills must be removed in their entirety and the affected areas returned to their preexisting elevation.

25. Designated Critical Resource Waters. Critical resource waters include, NOAA-designated marine sanctuaries, National Estuarine Research Reserves, National Wild and Scenic Rivers, critical habitat for Federally listed threatened and endangered species, coral

The District Engineer may also designate additional critical resource waters after notice and opportunity for comment.

(a) Except as noted below, discharges of dredged or fill material into waters of the US are not authorized by NWP's 7, 12, 14, 16, 17, 21, 29, 31, 35, 39, 40, 42, 43, and 44 for any activity within, or directly affecting, critical resource waters, including wetlands adjacent to such waters. Discharges of dredged or fill materials into waters of the US may be authorized by the above NWP's in National Wild and Scenic Rivers if the activity complies with General Condition 7. Further, such discharges may be authorized in designated critical habitat for Federally listed threatened or endangered species if the activity complies with General Condition 11 and the US Fish and Wildlife Service or the National Marine Fisheries Service has concurred in a determination of compliance with this condition.

(b) For NWP's 3, 8, 10, 13, 15, 18, 19, 22, 23, 25, 27, 28, 30, 33, 34, 36, 37, and 38, notification is required in accordance with General Condition 13, for any activity proposed in the designated critical resource waters including wetlands adjacent to those waters. The District Engineer may authorize activities under these NWP's only after he determines that the impacts to the critical resource waters will be no more than minimal.

26. Fills Within 100-Year Floodplains. For purposes of this General Condition, 100-year floodplains will be identified through the existing Federal Emergency Management Agency's (FEMA) Flood Insurance Rate Maps or FEMA-approved local floodplain maps.

(a) *Discharges in Floodplain; Below Headwaters.* Discharges of dredged or fill material into waters of the US within the mapped 100-year floodplain, below headwaters (i.e. five cfs), resulting in permanent above-grade fills, are not authorized by NWP's 39, 40, 42, 43, and 44.

(b) *Discharges in Floodway; Above Headwaters.* Discharges of dredged or fill material into waters of the US within the FEMA or locally mapped floodway, resulting in permanent above-grade fills, are not authorized by NWP's 39, 40, 42, and 44.

(c) The permittee must comply with any applicable FEMA-approved state or local floodplain management requirements.

27. Construction Period. For activities the Corps has not verified that and the project were commenced or under contract to commence by the expiration date of the NWP (or modification or revocation date), the work must be completed within 12- months after such date (including any modification that affects the project).

For activities that have been verified and the project was commenced or under contract to commence within the verification period, the work must be completed by the date determined by the Corps.

For projects that have been verified by the Corps, an extension of a Corps approved completion date maybe requested. This request must be submitted at least one month before the previously approved completion date.

D. Further Information

1. District engineers have authority to determine if an activity complies with the terms and conditions of an NWP.
2. NWP's do not obviate the need to obtain other Federal, State, or local permits, approvals, or authorizations required by law.
3. NWP's do not grant any property rights or exclusive privileges.
4. NWP's do not authorize any injury to the property or rights of others.
5. NWP's do not authorize interference with any existing or proposed Federal project.

Section 10 Special Condition: The permittee understands and agrees that, if future operations by the US require the removal, relocation, or other alteration, of the structure or work herein authorized, or if, in the opinion of the Secretary of the Army or its authorized representative, said structure or work shall cause unreasonable obstruction to the free navigation of the navigable waters, the permittee will be required, upon due notice from the Corps of Engineers, to remove, relocate, or alter the structure work or obstructions caused thereby, without expense to the US. No claim shall be made against the US on account of any such removal or alteration.

N O T I C E

**DIVISION OF WATER
(WATER QUALITY CERTIFICATION)
“GENERAL”**

PROJECT: Christian County (CR-1002), Item No. 2-1060.00
Replace Bridge & Approaches over West Fork of Pond River

The Division of Water has previously approved the Section 401 activities for this project by issuance of a “General” Water Quality Certification for Nationwide Permit #14, “Linear Transportation Crossings”. In order for this authorization to be valid, the attached conditions must be followed. The contractor shall post a copy of this Water Quality Certification in a conspicuous location at the project site for the duration of construction and comply with the general conditions as required.

To more readily expedite construction, the contractor may elect to alter the design or perform the work in a manner different from what was originally proposed and specified. Prior to commencing such alternative work, the contractor shall obtain **written** permission from the Division of Construction and the appropriate permit agency. A copy of any request to alter this proposal and subsequent responses shall be forwarded to the Division of Environmental Analysis, DA Permit Coordinator, for office records and for informational purposes.

JAMES E. BICKFORD
SECRETARY



PAUL E. PATTON
GOVERNOR

COMMONWEALTH OF KENTUCKY
NATURAL RESOURCES AND ENVIRONMENTAL PROTECTION CABINET
DEPARTMENT FOR ENVIRONMENTAL PROTECTION
FRANKFORT OFFICE PARK
14 REILLY RD
FRANKFORT KY 40601

General Certification--Nationwide Permit #14
Road Crossings

This General Certification is issued on March 17, 2002, in conformity with the requirements of Section 401 of the Clean Water Act of 1977, as amended (33USC 1314), as well as Kentucky Statute KRS 224.16-070.

The Commonwealth of Kentucky hereby certifies under Section 401 of the Clean Water Act (CWA) that it has reasonable assurances that applicable water quality standards under Kentucky Administrative Regulations Title 401, Chapter 5, established pursuant to Sections 301, 302, 304, 306 and 307 of the CWA, will not be violated for the activity covered under 33 CFR Part 330 Appendix A(B) (14), namely road crossings provided that the following conditions are met:

1. Individual road culvert or bridges, either for public or private purposes, that exceed 200 linear feet in width shall require an individual Water Quality Certification.
2. Stream and riparian impacts will be limited to the minimum necessary to construct the road crossing. For the purpose of this General Certification, streams are defined as a solid or dashed blue line on the most recent version of USGS 1:24,000 topographic map.
3. All equipment access and excavations within a stream, necessary to complete a road crossing project, shall be done in such a manner as to prevent degradation of Waters of the Commonwealth. Temporary equipment crossing structures shall be constructed with sufficient pipe capacity so as not to impede normal stream flow.
4. Stream bed gravel and rock shall not be used for construction material.
5. The stream crossing structure shall be constructed in such a manner that does not impede the movement of aquatic organisms. The bottom of any culverts shall be level with the stream bed.
6. This General Certification shall not apply to those waters of the Commonwealth identified as Outstanding State Resource Waters, Exceptional Waters or Cold Water Aquatic Habitat Waters, as designated by the Division of Water. An individual Water Quality Certification will be required for projects in these waters.
7. Stream impacts covered under this nationwide permit and undertaken by those persons defined as an agricultural operation under the Agricultural Water Quality Act must be completed in compliance with the Kentucky Agricultural Water Quality Plan.



Nationwide Permit # 14
Page Two

Non-compliance with the conditions of this general certification or violation of Kentucky state water quality standards may result in civil penalties.

This general certification will expire on March 19, 2007, or sooner if the COE makes significant changes to this nationwide permit.

SYP8161
31 JAN 2007

KENTUCKY TRANSPORTATION CABINET
COMMUNICATING ALL PROMISES (CAP)

Page: 1

Item No.	2 - 1060	Project Mgr.	JOE PLUNK
		County	CHRISTIAN
		Route	CR-1002
CAP #	Date of Promise	Promise made to:	Location of Promise
1	03-AUG-06	JOE PLUNK	BRIDGE
CAP Description			
EXISTING BRIDGE TO BE DISASSEMBLED AND DELIVERED TO CAROLYN SUE TYSON AS PER MEMORANDUM OF AGREEMENT. SEE GENERAL NOTE SHEET FOR INSTRUCTIONS.			
2	29-JAN-07	JOE PLUNK	BRIDGE
CAP Description			
DISREGARD CAP #1			
3	29-JAN-07	JOE PLUNK	BRIDGE
CAP Description			
EXISTING BRIDGE IS A HISTORIC BRIDGE, WHICH SHALL BE REMOVED BY PROPERTY OWNER (ROCKFORD FARM). PROPERTY OWNER'S PRIVATE CONTRACTOR WILL COORDINATE WITH DISTRICT ENVIRONMENTAL COORDINATOR AND ENGINEER AND SHALL BE READY TO REMOVE BRIDGE WITHIN SEVEN (7) DAYS OF NOTICE TO PROCEED, AS PER MAINTENANCE AGREEMENT.			
4	31-JAN-07	JOE PLUNK	BRIDGE
CAP Description			
BRIDGE SHALL NOT BE REMOVED UNTIL CONTRACTOR HAS INSTALLED TRAFFIC CONTROL DEVICES AND CLOSED ROAD.			
5	31-JAN-07	JOE PLUNK	BRIDGE
CAP Description			
TO AVOID DISRUPTING SCHOOL BUS ROUTE, PROJECT START DATE SHALL BEGIN NO EARLIER THAN JUNE 1, 2007, WITH A COMPLETION DATE SET FOR JULY 31, 2007.			

PART II

SPECIFICATIONS AND STANDARD DRAWINGS

**Supplemental Specifications to The Standard Specifications
for Road and Bridge Construction, 2004 Edition**
(Effective with the January 19, 2007 Letting)

<p>SUBSECTION: 105.07 COOPERATION WITH UTILITIES. REVISION: In the last paragraph, replace “KRS 367 Sections 1 through 10” with “KRS 367.4901 through 367.4917”</p>
<p>SUBSECTION: 108.01 SUBCONTRACTING OF CONTRACT. REVISION: Replace the second and third sentence of the first paragraph with the following:</p> <p>When the Engineer gives such consent, the Engineer will allow the Contractor to subcontract a portion, but the Contractor must perform with his own organization work amounting to no less than 30 percent of the total Contract cost. The Department will not allow any subcontractor to exceed the percentage to be performed by the Contractor and will require the Contractor to maintain a supervisory role over the entire project.</p>
<p>SUBSECTION: 109.07 PRICE ADJUSTMENT. REVISION: Replace the section with the following:</p> <p>109.07 PRICE ADJUSTMENTS. Due to the fluctuating costs of petroleum products, the Department will adjust the compensation of specified liquid asphalt items and diesel fuel in contracts when contract quantity thresholds are met.</p> <p>109.07.01 Liquid Asphalt. The Department will compare the Kentucky Average Price Index (KAPI), for the month that the Contract is let, to the index for the month that the Contractor places the material on the project to determine the percent change. When the original contract quantity for asphalt items is equal to or greater than 3,000 tons and when the average price of the liquid asphalt products increases or decreases more than 5 percent, the Department will adjust the Contractor’s compensation. The KAPI is calculated monthly using the average price, per ton at the terminal, from the active suppliers of liquid asphalt.</p> <p><u>Adjustable Contract Items:</u></p> <ul style="list-style-type: none"> • Asphalt Curing Seal • Asphalt Material for Prime • Asphalt Base, All Classes • Asphalt Binder • Asphalt Surface, All Classes • Sand Asphalt Surface • Asphalt Open-Graded Surface • Asphalt Seal Coat • Asphalt Mixture for Leveling and Wedging • Drainage Blanket - Type II - Asphalt <p>The Department will determine the price adjustment using the following formulas:</p> <p><u>When PC is greater than PL</u> Asphalt Price Adjustment = $(Q \times A) / 100 \times PL \times [(PC - PL) / PL - 0.05]$</p> <p><u>When PC is less than PL</u> Asphalt Price Adjustment = $(Q \times A) / 100 \times PL \times [(PC - PL) / PL + 0.05]$</p> <p>Where: Q = Tons of material or mixture placed each month. A = Percent of material or mixture that is asphalt. PL = KAPI for the month that the Contract is let. PC = KAPI for the month that the Contractor places the material or mixture.</p> <p>The job-mix formula for asphalt base, binder, and surface mixtures determines “A”, which is the percent of asphalt. For recycled mixtures, the Department will determine the adjustment for the new asphalt cement only. The Department will consider materials for prime and seal as 100 percent asphalt.</p>

**Supplemental Specifications to The Standard Specifications
for Road and Bridge Construction, 2004 Edition**
(Effective with the January 19, 2007 Letting)

Revision
Continued

109.07.02 Fuel. The Department will adjust the Contractor's compensation when the average price of diesel fuel increases or decreases more than 5 percent and the original Contract quantity for the item on which the fuel is consumed is equal to or greater than the threshold quantities listed in the following table.

<u>Item</u>	<u>Threshold Quantity</u>	<u>Fuel/Work</u>
Roadway Excavation	10,000 cubic yards	0.25
Embankment-in-Place	10,000 cubic yards	0.25
Borrow Excavation	10,000 cubic yards	0.25
DGA Base or Crushed Stone Base	5,000 tons	0.52
Stabilized Aggregate Base	5,000 tons	0.52
Drainage Blanket, Cement Treated or Untreated	5,000 tons	0.52
Drainage Blanket, Asphalt Treated	5,000 tons	3.00
Crushed Sandstone Base (Cement Treated)	5,000 tons	0.52
Hot-Mixed Asphalt Mixtures for Pavements or Shoulders	3,000 tons ⁽¹⁾	3.00
PCC Pavement, Base, or Shoulders	2,000 square yards ⁽²⁾	0.14

⁽¹⁾Total of all hot mixed asphalt Contract items.

⁽²⁾Total of all JPC pavement, JPC shoulder, and PCC base, Contract items.

The Department will determine the price adjustment using the following formulas:

When PC is greater than PL

$$\text{Fuel Price Adjustment} = Q \times F \times PL \times [(PC-PL)/PL - 0.05]$$

When PC is less than PL

$$\text{Fuel Price Adjustment} = Q \times F \times PL \times [(PC-PL)/PL + 0.05]$$

Where:

Q = Quantity for applicable item placed or performed that month.

F = The fuel to work unit ratio for each applicable item.

PL = Average reseller price of diesel fuel, excluding taxes, discounts, and superfund line items, in the Kentucky region for the month that the Contract is let.

PC = Average reseller price of diesel fuel, excluding taxes, discounts, and superfund line items, in the Kentucky region for the month that the Contractor uses the fuel on the project.

109.07.03 Payments and Deductions. When thresholds are met, the Department will adjust the Contractor's compensation for each eligible pay item, paid or deducted, monthly.

If later price decreases indicate that the Department made an overpayment, the Department will withhold the overpayment from succeeding pay estimates on the project, or the Contractor shall immediately refund the over payment to the Department.

When the Contractor places materials during any month after the month that the Contract time (including all approved time extensions) expires, the Department will use the average price for the month that the Contractor places the material or the average price for the last month of the Contract time; whichever is least.

The Department will not grant a time extension for any overrun in the Contract amount due to payments made according to this section. The Department will not make any additional compensation due to adjustments made according to this section.

The Department will adjust the Contractor's compensation on the following months pay estimate and on the final pay estimate. The Department will make the final adjustment of the Contractor's compensation on the final estimate for the project.

**Supplemental Specifications to The Standard Specifications
for Road and Bridge Construction, 2004 Edition**
(Effective with the January 19, 2007 Letting)

SUBSECTION: 110.01 MOBILIZATION. REVISION: Replace the third paragraph with the following: Do not bid an amount for Mobilization that exceeds 5 percent of the sum of the total amounts bid for all items in the Bid Proposal, excluding Mobilization, Demobilization, and contingent amounts established for adjustments and incentives. The Department will automatically adjust any bids in excess of this amount to 5 percent for bid comparisons. The Department will base the award on the maximum allowable bid of 5 percent. If any errors in unit bid prices for other Contract items in a Contractor's Bid Proposal are discovered after bid opening and such errors reduce the total amount bid for all other items, excluding Mobilization, Demobilization, and contingent amounts established for adjustments and incentives, so that the percent bid for Mobilization is larger than 5 percent, the Department will adjust the amount bid for Mobilization to 5 percent of the sum of the corrected total bid amounts.
SUBSECTION: 110.02 DEMOBILIZATION. REVISION: Replace the first sentence of the third paragraph with the following: Do not bid an amount for Demobilization that is less than 1.5 percent of the sum of the total amounts bid for all other items in the Bid Proposal, excluding Mobilization, Demobilization, and contingent amounts established for adjustments and incentives.
SUBSECTION: 206.03.03 Compaction. REVISION: Replace "KM 64-412" with "KM 64-002"
SUBSECTION: 212.03.03 Permanent Seeding and Protection. PART: B) Procedures for Permanent Seeding. REVISION: Add the following after the fourth sentence: Unless the Engineer directs otherwise, track all slopes 3:1 or greater. Ensure that tracking is performed up and down and not across.
SUBSECTION: 213.03.01 Best Management Practices (BMP). REVISION: Replace the third sentence of the first paragraph with the following: Ensure that the BMP provides storage for 3,600 cubic feet of water per surface acre disturbed.
SUBSECTION: 213.03.03 Inspection and Maintenance REVISION: Replace both "0.1-inch" references with "0.5-inch".
SUBSECTION: 213.03.05 Temporary Control Measures. PART: B) Silt Checks. REVISION: B) Silt Checks. Use one of the following types: 1) Silt Check Type II - Crushed stone such as cyclopean stone riprap, quarry run stone, or other size material approved by the Engineer, dumped in place and shaped to the configuration required. 2) Silt Check Type III - Blasted or broken rock dumped in place and shaped to the configuration required. Remove and properly dispose of sediment deposited at silt checks as necessary. When no longer needed, remove the silt checks and dispose of surplus materials as excavated materials according to Section 204. Seed and protect the entire area disturbed, as directed. Do not leave silt checks in place after completion of the project unless allowed by the Engineer or specified in the Plans.
SUBSECTION: 213.03.05 Temporary Control Measures. PART: G) Temporary Mulch. REVISION: Replace the last sentence with the following: Place temporary mulch to an approximate 2-inch loose depth (2 tons per acre) and apply tackifier.
SUBSECTION: 213.04.15 Temporary Silt Ditch. REVISION: Replace with the following: The Department will measure the quantity in linear feet.

**Supplemental Specifications to The Standard Specifications
for Road and Bridge Construction, 2004 Edition**
(Effective with the January 19, 2007 Letting)

SUBSECTION:	213.04 MEASUREMENT.
REVISION:	Add the following Subsection: 213.04.24 Clean Temporary Silt Ditch. The Department will measure the quantity in linear feet along the ditch line.
SUBSECTION:	213.05 PAYMENT.
REVISION:	Add the following lines: 20594 Temporary Silt Ditch Linear Foot 20601 Clean Temporary Silt Ditch Linear Foot
SUBSECTION:	303.03.01 Mixture
PART:	C) Cement Treated Mixture.
REVISION:	Delete the "For asphalt pavements" from the second paragraph.
SUBSECTION:	303.03.01 Mixture
PART:	C) Cement Treated Mixture.
REVISION:	Delete requirement "2".
SUBSECTION:	402.03.02 Acceptance.
PART:	D) Testing Responsibilities.
NUMBER:	4) Density.
REVISION:	Replace the first sentence of the third paragraph with the following: For surface mixtures placed on driving lanes and ramps, furnish 2 cores per subplot to the nearest laboratory facility (Contractor or Department lab) for density determination by the Engineer.
SUBSECTION:	402.03.02 Acceptance.
PART:	H) Unsatisfactory Work.
NUMBER:	1) Based on Lab Data.
REVISION:	Replace the "AASHTO MP2" references in the second paragraph with "AASHTO M 323".
SUBSECTION:	402.04 MEASUREMENT.
REVISION:	Replace the last sentence with the following: The Department will not measure construction of rolled rumble strips or pavement wedge texturing for payment and will consider them incidental to the asphalt mixture.
SUBSECTION:	402.04.01 Weight.
REVISION:	Replace first sentence of the second paragraph with the following: The Department will determine the bulk, oven-dry specific gravity for the fine and coarse aggregates according to KM64-605 and AASHTO T 85, respectively.
SUBSECTION:	402.04.02 Thickness on New Construction.
REVISION:	Delete the third paragraph and add the following at the end of the subsection: The Department will not measure initial thickness check coring or coring of corrective work for payment and will consider it incidental to the asphalt mixture.

**Supplemental Specifications to The Standard Specifications
for Road and Bridge Construction, 2004 Edition**
(Effective with the January 19, 2007 Letting)

SUBSECTION:	402.05.02												
PARTS:	Lot Pay Adjustment Schedule, Compaction Option A, Base and Binder Mixtures Lot Pay Adjustment Schedule, Compaction Option A, Surface Mixtures Lot Pay Adjustment Schedule, Compaction Option B Mixtures												
REVISION:	Replace the VMA table with the following:												
<table border="1" style="margin: auto; border-collapse: collapse;"> <thead> <tr> <th colspan="2">VMA</th> </tr> <tr> <th style="width: 50%;">Pay Value</th> <th style="width: 50%;">Deviation From Minimum</th> </tr> </thead> <tbody> <tr> <td style="text-align: center;">1.00</td> <td style="text-align: center;">≤ 0.5 below min. VMA</td> </tr> <tr> <td style="text-align: center;">0.95</td> <td style="text-align: center;">0.6-1.0 below min.</td> </tr> <tr> <td style="text-align: center;">0.90⁽²⁾</td> <td style="text-align: center;">1.1-1.5 below min.</td> </tr> <tr> <td style="text-align: center;">⁽¹⁾/₍₂₎</td> <td style="text-align: center;">> 1.5 below min.</td> </tr> </tbody> </table>		VMA		Pay Value	Deviation From Minimum	1.00	≤ 0.5 below min. VMA	0.95	0.6-1.0 below min.	0.90 ⁽²⁾	1.1-1.5 below min.	⁽¹⁾ / ₍₂₎	> 1.5 below min.
VMA													
Pay Value	Deviation From Minimum												
1.00	≤ 0.5 below min. VMA												
0.95	0.6-1.0 below min.												
0.90 ⁽²⁾	1.1-1.5 below min.												
⁽¹⁾ / ₍₂₎	> 1.5 below min.												
SUBSECTION:	403.03.03 Preparation of Mixture.												
PART:	A) Mixture Composition.												
REVISION:	Replace the "AASHTO MP2" reference in the first paragraph with "AASHTO M 323". From the aggregate requirements list, delete 3) Type C.												
SUBSECTION:	403.03.03 Preparation of Mixture.												
PART:	C) Mix Design Criteria.												
REVISION:	Replace the "AASHTO MP2" references with "AASHTO M 323". Replace the "AASHTO PP28" references in the second paragraph with "AASHTO R 35".												
SUBSECTION:	403.03.03 Preparation of Mixture.												
PART:	C) Mix Design Criteria.												
NUMBER	1) Preliminary Mix Design.												
REVISION:	Add the following footnote to the table and associate it with the ESAL's field "<0.3": * For CL1 ASPH SURF 0.38D PG64-22 only.												
SUBSECTION:	403.03.06 Thickness Tolerances.												
PART:	B) New Construction.												
REVISION:	Replace the first paragraph with the following: Under the Engineer's supervision, perform coring for thickness checks according to KM 64-420, as soon as practical after completion of all, or a major portion, of the asphalt base. The Engineer will measure the cores. Fill all core holes either with compacted asphalt mixture or non-shrink grout. Complete all remedial overlay work before placing the final course.												

**Supplemental Specifications to The Standard Specifications
for Road and Bridge Construction, 2004 Edition
(Effective with the January 19, 2007 Letting)**

SUBSECTION: 403.03.08 Rumble Strips.
REVISION: Replace with the following:

403.03.08 Shoulder Rumble Strips and Pavement Wedge Texturing.

A) Shoulder Rumble Strips.

1) Interstates and Parkways. Construct sawed rumble strips on all mainline shoulders to the dimensions shown below. Do not place rumble strips on ramps.

2) Other Roads. Construct rolled rumble strips on shoulders of facilities with posted speed limits greater than 45 MPH. Unless specified in the plans or directed by the Engineer, do not construct rumble strips on facilities with posted speed limits of 45 MPH or less.

Construct rolled rumble strips on mainline shoulders to the dimensions shown below. On shoulders less than 3 feet wide, shorten the width and distance of the strips as the Engineer directs. Time the rolling operation so indentations are at the specified size and depth without causing unacceptable displacement of the asphalt mat. Correct unacceptable rolled rumble strips by sawing.

B) Pavement Wedge Texturing. Perform texturing on all pavement wedges constructed monolithically with the mainline or constructed using a surface mixture. When furnishing Asphalt Mixture for Pavement Wedge, binder, or a base mixture for the wedge, the Department will not require texturing.

Texture to the dimensions shown below. On wedges less than 3 feet, shorten the length and distance of the texturing as the Engineer directs. Time the rolling operation so indentations are at the specified size and depth without causing unacceptable displacement of the asphalt mat.

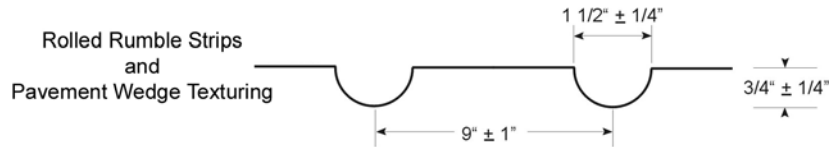

Place one foot out from the mainline pavement and to a width of 2 feet.

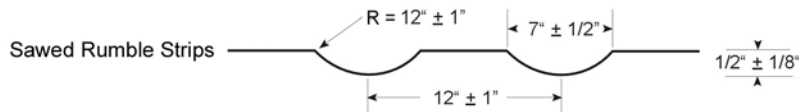

Place one foot out from the mainline pavement and to a width of 16 inches.

SUBSECTION: 403.04.03 Asphalt Mixtures.
REVISION: Replace the second sentence with the following:

The Department will not measure rolled rumble strips or pavement wedge texturing for payment and will consider them incidental to this bid item.

SUBSECTION: 403.04.07 Sawed Rumble Strips.
REVISION: Add the following subsection:

403.04.07 Sawed Rumble Strips. The Department will measure the quantity in linear feet. When rolled in rumble strips are specified, the Department will not measure sawed rumble strips for payment and will consider them incidental to the asphalt mixture.

**Supplemental Specifications to The Standard Specifications
for Road and Bridge Construction, 2004 Edition**
(Effective with the January 19, 2007 Letting)

SUBSECTION:	403.05 PAYMENT						
REVISION:	Add the following bid item:						
	<table border="0"> <thead> <tr> <th align="left"><u>Code</u></th> <th align="left"><u>Pay Item</u></th> <th align="left"><u>Pay Unit</u></th> </tr> </thead> <tbody> <tr> <td>20362</td> <td>Shoulder Rumble Strips – Sawed</td> <td>Linear Foot</td> </tr> </tbody> </table>	<u>Code</u>	<u>Pay Item</u>	<u>Pay Unit</u>	20362	Shoulder Rumble Strips – Sawed	Linear Foot
<u>Code</u>	<u>Pay Item</u>	<u>Pay Unit</u>					
20362	Shoulder Rumble Strips – Sawed	Linear Foot					
SUBSECTION:	501.03.20 Opening to Public Traffic.						
REVISION:	Delete the last sentence of the first paragraph.						
SUBSECTION:	501.03.21 Tolerance in Pavement Thickness.						
REVISION:	Add the following: Core the pavement as the Engineer directs.						
SUBSECTION:	501.04.06 Thickness.						
REVISION:	Add the following: The Department will not measure coring for payment and will consider it incidental to the concrete pay items.						
SUBSECTION:	502.03 CONSTRUCTION.						
PART:	C) Curing and Protecting Pavement.						
NUMBER:	3)						
REVISION:	Replace the last sentence with the following: The Department will allow permanent removal of the cover when the concrete attains the required opening strength of 3,000 psi.						
SUBSECTION:	502.03 CONSTRUCTION.						
PART:	D) Strength Testing and Opening to Traffic.						
NUMBER:	2) Testing.						
REVISION:	Replace the second paragraph with the following: When the average compressive strength is 3,000 psi, the Department will allow the pavement to be opened to traffic and will test the remaining sets of cylinders at the required age. When the average compressive strength is less than 3,000 psi at the required age, do not open the pavement to traffic until the pavement has been in place for 7 days. The Engineer may accept the pavement based on additional testing.						
SUBSECTION:	503.03.09 Ride Quality.						
REVISION:	Replace parts 5) and 6) with the following: 5) Perform corrective work to achieve the required IRI by regrinding the entire width of the traffic lane at areas having a high IRI. The Engineer may exclude pavement areas where grinding alone will not correct deficiency. 6) The Department will create a strip chart when the test results show that the IRI is greater than 60 or upon request for lower IRI values.						
SUBSECTION:	601.03.02 Concrete Producer Responsibilities.						
REVISION:	Replace the first sentence with the following: Use a concrete producer from the List of Approved Materials when the quantity of concrete delivered to the project in a plastic condition is 250 cubic yards or more. Ensure that the concrete producer complies with the following requirements:						

**Supplemental Specifications to The Standard Specifications
for Road and Bridge Construction, 2004 Edition**
(Effective with the January 19, 2007 Letting)

SUBSECTION: 601.03.02 Concrete Producer Responsibilities. PART: C) Quality Control. REVISION: Replace the first paragraph with the following: Take full responsibility for the batch weight calculations and quality control of concrete mixtures at the plant. Ensure that the Level II concrete technician is present when work is in progress and is responsible for inspecting trucks, batch weight calculations, monitoring batching, making mixture adjustments, reviewing the slump, air content and unit weight tests, and monitoring the concrete temperature, all to provide concrete to the project conforming to specifications. A Level I concrete technician is responsible for testing production material for slump, entrained air, unit weight and temperature of the mixture. Ensure the technician performs all sampling and testing according to the appropriate Kentucky Methods. Delete the third paragraph.
SUBSECTION: 601.03.02 Concrete Producer Responsibilities. PART: F) Records. REVISION: Retain all concrete technician records, test results and batch tickets pertaining to concrete produced for a Department project for at least 3 years after formal acceptance of the project. Make all records available to the Engineer and the Contractor on the project for review upon request.
SUBSECTION: 601.03.02 Concrete Producer Responsibilities. PART: G) Mix Designs. REVISION: Replace the last sentence of the first paragraph with the following: Before producing any concrete for the project, submit a proposed mixture design to the Engineer and obtain the District Materials engineer's or the Central Office Material's approval.
SUBSECTION: 601.03.02 Concrete Producer Responsibilities. PART: G) Mix Designs. NUMBER: 1) New Mixture Designs. REVISION: Replace the first sentence with the following: Base the proposed mix design on standard Department methods unless the District Materials Engineer, or Central Office Materials approves otherwise.
SUBSECTION: 601.03.02 Concrete Producer Responsibilities. PART: G) Mix Designs. NUMBER: 1) Changes in Approved Mix Designs. REVISION: Replace the second sentence with the following: The District Materials Engineer or Central Office Materials will provide an average value of the specific gravity aggregate absorption.
SUBSECTION: 601.03.02 Concrete Producer Responsibilities. PART: G) Mix Designs. NUMBER: 3) Changes in Approved Mix Designs. LETTER: g) REVISION: Replace the fourth and fifth sentence with the following: Central Office Materials will observe all phases of the trial batches. Have the producer submit a report containing mix proportions and test results for slump, air content, water/cement ratio, unit weight, and compressive strength for each trial batch to the Engineer for Central Office Materials review and approval.
SUBSECTION: 601.03.02 Concrete Producer Responsibilities. PART: G) Mix Designs. NUMBER: 2) Approval. REVISION: Replace the first sentence with the following: The District Materials Engineer or Central Office Materials will base approval of the mixture design on the following criteria:

**Supplemental Specifications to The Standard Specifications
for Road and Bridge Construction, 2004 Edition**
(Effective with the January 19, 2007 Letting)

<p>SUBSECTION: 601.03.02 Concrete Producer Responsibilities. PART: G) Mix Designs. NUMBER: 3) Changes in Approved Mix Designs. REVISION: Replace the first sentence with the following:</p> <p style="padding-left: 40px;">Do not change the source of supply of the mixture ingredients without the District Materials Engineer's or Central Office Materials written permission.</p> <p style="padding-left: 40px;">Replace the third sentence with the following:</p> <p style="padding-left: 40px;">Upon the District Materials Engineer's or Central Office Materials written approval, the Department will allow the use of aggregate from the new source.</p>
<p>SUBSECTION: 601.03.03 Proportioning and Requirements. PART: A) Concrete. TABLE: INGREDIENT PROPORTIONS AND REQUIREMENTS FOR VARIOUS CLASSES OF CONCRETE REVISION: Under Class of Concrete replace "A"AA⁽⁹⁾" with "AAA⁽⁸⁾"</p>
<p>SUBSECTION: 601.03.03 Proportioning and Requirements. PART: A) Concrete. FOOTNOTE: (6) REVISION: Add the following after the first sentence of the first paragraph:</p> <p style="padding-left: 40px;">For products with voids, the slump may be increased to 7 inches.</p> <p style="padding-left: 40px;">Replace the "0.3" requirement for Spring and Fall mix designs with "0.37".</p>
<p>SUBSECTION: 601.03.03 Proportioning and Requirements. PART: A) Concrete. FOOTNOTE: (7) REVISION: Replace with the following:</p> <p style="padding-left: 40px;">The precast fabricator may increase the slump of Class A concrete to a maximum of 7 inches provided the fabricator uses a high range water reducer (Type F and G) and maximum water/cement ratio of 0.46.</p>
<p>SUBSECTION: 601.03.03 Proportioning and Requirements. PART: E) Measuring. NUMBER: 3) Water. REVISION: Delete the last sentence of the second paragraph.</p>
<p>SUBSECTION: 601.03.03 Proportioning and Requirements. PART: E) Measuring. NUMBER: 4) Measuring Admixtures. REVISION: Replace with the following:</p> <p style="padding-left: 40px;">4) Measuring Admixtures. Introduce liquid admixtures into the concrete batch along with, or as part of, the mixing water. Keep air-entraining admixtures completely separate from all other admixtures until introduction into the batch. Maintain and equip dispensing equipment to ensure no chlorides are introduced into any Department mix.</p> <p style="padding-left: 40px;">Use approved dispensing equipment with a meter, gauge, or scale that can accurately be pre-set for the needed amount of admixture and can consistently deliver quantities of admixture to successive batches at any setting with satisfactory accuracy. The dispensing equipment must be visible to the batch operator if the actual dispensed amounts are not recorded on the computer batch ticket. Ensure admixture dispensers are inspected, calibrated and certified every 6 months.</p> <p style="padding-left: 40px;">The Department may allow admixtures to be added, to the truck, at the project site provided the Engineer's approval is obtained first.</p>

**Supplemental Specifications to The Standard Specifications
for Road and Bridge Construction, 2004 Edition
(Effective with the January 19, 2007 Letting)**

SUBSECTION:	601.03.04 Classes and Primary Uses.
REVISION:	Add the following part: R) Dry Cast. Precast units.
SUBSECTION:	601.03.05 Admixtures.
REVISION:	Replace the last sentence of the fourth paragraph with the following: Store admixtures where the liquid temperatures can be maintained between 32 and 110 °F.
SUBSECTION:	601.03.09 Placing Concrete.
PART:	D) Weather Limitations and Protection.
REVISION:	Delete the last sentence of paragraph two.
SUBSECTION:	605.03 CONSTRUCTION.
REVISION:	Insert the following sentence after the first sentence: Ensure all non-composite box beam concrete contains an approved corrosion inhibitor from the List of Approved Materials.
SUBSECTION:	605.03.03 Casting.
REVISION:	Delete the first sentence in the first paragraph. Add the following after the first sentence of the third paragraph: Do not vibrate Self-Consolidating Concrete (SCC).
SUBSECTION:	605.03.04 Tack welding.
REVISION:	Replace the first sentence with the following: When tack welding steel reinforcement, use ASTM A 706 steel and conform to the following conditions.
SUBSECTION:	605.03.04 Tack Welding.
NUMBER:	3)
REVISION:	Replace the first sentence with the following: Tack weld only at intersections of bars except do not tack weld in any bend or within 2 bar diameters of a bend.
SUBSECTION:	605.03.04 Tack Welding.
NUMBER:	5)
REVISION:	Replace the last sentence with the following: Each sample must meet the minimum requirement for elongation, ductility, tensile and yield strength of the bar stock.
SUBSECTION:	605.03.04 Tack Welding.
NUMBER:	6)
REVISION:	Delete the last sentence.
SUBSECTION:	605.03.04 Tack Welding.
REVISION:	Change footnote “(4) (d)” to “(5)”
SUBSECTION:	605.03.07 Removal of Forms and Surface Finish.
REVISION:	Add the following sentence before the last sentence of the paragraph: Finish dry cast products according to the Precast/Prestressed Concrete Manual.
SUBSECTION:	611.02.01 Concrete.
REVISION:	Replace with the following: Conform to Subsections 601.02 and 601.03 and the Precast/Prestress Concrete Manual.
SUBSECTION:	611.03.02 Precast Unit Construction.
REVISION:	Replace “AASHTO C 1433” with “ASTM C 1433”

**Supplemental Specifications to The Standard Specifications
for Road and Bridge Construction, 2004 Edition**
(Effective with the January 19, 2007 Letting)

SUBSECTION: NUMBER: REVISION:	611.03.02 Precast Unit Construction. 2) Replace with the paragraph with the following: Mark all box culverts sections with the following information on the inside top of each section with letters no less than 2 inches high: a) Span, rise, maximum and minimum design earth cover, and KY Table 3. b) Date of manufacture. c) Name and trademark of the manufacturer. For entrance and exit box sections, indent the required information. Mark interior sections by indenting or with waterproof paint.
SUBSECTION: PART: NUMBER: REVISION:	701.02.05 Backfill Materials. A) Granular Backfill. 1) Remove "A2" from the list of acceptable materials.
SUBSECTION: REVISION:	701.03.03 Pipe Bedding. Replace with the following: 701.03.03 Pipe Bedding. A) Reinforced Concrete Pipe. Construct bedding according to the Standard Drawings and this section. 1) Type 1 Installation. When working on a rock foundation, place bedding to a depth of 6 inches or equal to $Bc/12$, the pipe diameter in inches divided by 12, whichever is greater. For all other foundations, place a minimum of 4 inches of bedding. Shape the bedding to conform to the invert shape throughout the entire width and length of the proposed structure. Compact the bedding, but leave the center third of the pipe diameter ($Bc/3$) uncompacted. Place and compact additional bedding material in lifts 6 inches or less to an elevation of 0.30 the culvert diameter. 2) Type 4 Installation. When working on a rock foundation, place bedding to a depth of 6 inches or equal to $Bc/12$, the pipe diameter in inches divided by 12, whichever is greater. For all other foundations, place a minimum of 4 inches of bedding. B) Corrugated Metal, Thermoplastic, and Structural Plate Pipe. Place and compact bedding to provide 4 inches of bedding below the outside invert of the pipe after shaping. Shape the bedding to conform to the invert shape throughout the entire width and length of the proposed structure. Place and compact additional bedding material in lifts 6 inches or less to an elevation of 0.30 the culvert diameter.
SUBSECTION: PART: REVISION:	701.03.06 Initial Backfill. A) Reinforced Concrete Replace with the following: A) Reinforced Concrete Pipe. 1) Type 1 Installation. When the top of the pipe is not within one pipe diameter of the subgrade, backfill with granular backfill, additional bedding material, or flowable fill from the top of the bedding to an elevation equal to 1/2 the pipe diameter, and either granular backfill, flowable fill, or embankment material in 6-inch lifts to an elevation of one-foot above the pipe. 2) Type 4 Installation. Backfill from the top of the bedding with granular backfill, flowable fill, or embankment material in 6-inch lifts to an elevation of one-foot above the pipe. The Department will allow Type 4 installations for median drains and pipe installations located 35 feet or more from the edge of shoulder, back of curb, or any paved surface.

**Supplemental Specifications to The Standard Specifications
for Road and Bridge Construction, 2004 Edition
(Effective with the January 19, 2007 Letting)**

SUBSECTION:	701.05 PAYMENT.
REVISION:	Replace bid item “2599 Fabric-Geotextile, Type IV Square Yard” with “21433ES214 Fabric-Geotextile, Type IV for Pipe Square Yard ⁽²⁾ ”
	Replace foot note “** The unit bid price is \$2.00 per square yard for Geotextile Fabric, Type III” with “ ⁽²⁾ The unit price is \$2.00 per square yard for Fabric-Geotextile, Type IV for Pipe”
SUBSECTION:	710.02.15 Plastic Adjusting Rings.
REVISION:	Replace this section with:
	710.02.15 Plastic or Rubber Adjusting Rings. Provide plastic or rubber adjusting rings that are on the Department’s List of Approved Materials.
SUBSECTION:	710.03.03 Adjusted Small Drainage Structures.
REVISION:	Replace the last sentence of the first paragraph:
	For plastic or rubber adjusting rings, install and seal according to the manufacturer’s recommendations.
SUBSECTION:	711.02 MATERIALS.
REVISION:	Replace with the following:
	Conform to the Contract requirements.
SUBSECTION:	713.03 CONSTRUCTION.
REVISION:	Add the following after the third paragraph:
	Offset longitudinal lines at least 2 inches from longitudinal pavement construction joints. Offset longitudinal lane lines on multi-lane highways 2 inches towards the median.
SUBSECTION:	714.03.06 Proving Period for Durable Markings.
PART:	B) Failure.
REVISION:	Replace the first sentence with the following:
	During the proving period, the Department will consider markings defective when the retroreflectivity falls below the minimum required or the material fails to meet the other requirements of A) above. Additionally, when more than 10 percent of any one-mile section or individual gore area is defective, the Department will consider the entire section defective.
SUBSECTION:	716.03.08 Testing.
REVISION:	Replace “10 megohms” with “100 megohms”
SUBSECTION:	723.03 CONSTRUCTION.
REVISION:	Replace the first sentence of the fourth paragraph with the following:
	Set right-of-way markers within 12 inches of the right-of-way line.
SUBSECTION:	724.02.01 Plants.
REVISION:	Replace the reference “American Association of Nurserymen” with “American Nursery and Landscape Association”.
SUBSECTION:	801.01 REQUIREMENTS.
REVISION:	Add the following sentence after the third sentence of the first paragraph:
	Mills must request and be approved by the Department to supply cement with an SO ₃ content above the value in Table 1 of ASTM C 150.
SUBSECTION:	804.01.03 Conglomerate Sand.
REVISION:	Replace second sentence of the paragraph with the following:
	Conglomerate sand may include some material which has been produced by crushing larger pieces of the parent material.
SUBSECTION:	804.02 Approval.
REVISION:	Replace first sentence of the second paragraph with the following:
	The Department will consider a source for inclusion on the Aggregate Source List when the aggregate producer complies with KM 64-608 and provides the following:

**Supplemental Specifications to The Standard Specifications
for Road and Bridge Construction, 2004 Edition
(Effective with the January 19, 2007 Letting)**

SUBSECTION: 804.03 Concrete. REVISION: Second sentence in first paragraph should be a separate paragraph immediately following the first and should read as follows: Provide natural, crushed, or conglomerate sand. The Department will allow any combination of natural, crushed, or conglomerate sand when the combination is achieved in the concrete plant weigh hopper. The Engineer may allow other sands. Use natural or conglomerate sands as fine aggregates in concrete intended as a wearing surface for traffic. Conform to the following:
SUBSECTION: 804.04.03 Polish-Resistant Aggregate. REVISION: Add the following paragraph: Provide a signed certification from the aggregate producer for the manufactured polish-resistant fine aggregate stating that the aggregate is supplied from the approved parent material as found on the Department's List of Approved Materials, Polish-Resistant Aggregate Source List and Guidelines on the Division of Materials' webpage.
SUBSECTION: 804.04.04 Requirements for Combined Aggregates. PART: D) Absorption. REVISION: Delete the first sentence and replace the second sentence with the following: Provide total combined fine aggregates having a water absorption of no more than 4.0 percent.
SUBSECTION: 804.11 Sampling and Testing. REVISION: For Absorption (Fine Aggregate), replace method "AASHTO T 84" with "KM 64-605"
SUBSECTION: 805.02 Approval. REVISION: Replace first sentence of the second paragraph with the following: The Department will consider a source for inclusion on the Aggregate Source List when the aggregate producer complies with KM 64-608 and provides the following:
SUBSECTION: 805.04.01 JPC Base, JPC Pavement, JPC Shoulders, and Concrete for Bridge Decks. REVISION: Replace the subsection heading and first sentence with the following: 805.04.01 JPC Base, JPC Pavement, JPC Shoulders, Concrete for Bridge Decks, and Precast Products. Add the following paragraph: Provide a signed certification from the aggregate producer for the approved freeze-thaw coarse aggregate stating that the aggregate is supplied from the approved parent material as found on the Department's List of Approved Materials and Concrete Aggregate Restriction List.
SUBSECTION: 805.04.01 JPC Base, JPC Shoulders, and Concrete for Bridge Decks. PART: 3) REVISION: Replace the "tests" with "test" in the last sentence.
SUBSECTION: 805.05.05 Polish-Resistant Aggregate. REVISION: Add the following paragraph: Provide a signed certification from the aggregate producer for the manufactured polish-resistant coarse aggregate stating that the aggregate is supplied from the approved parent material as found on the Department's List of Approved Materials, Polish-Resistant Aggregate Source List and Guidelines on the Division of Materials' webpage.

**Supplemental Specifications to The Standard Specifications
for Road and Bridge Construction, 2004 Edition**
(Effective with the January 19, 2007 Letting)

SUBSECTION: 805.13.01 Cyclopean Stone Riprap and Channel Lining Class III. REVISION: Replace the subsection with the following: 805.13.01 Cyclopean Stone Riprap and/or Channel Lining Class III. Provide material meeting the general requirements of Section 805. Ensure that 100 percent passes through a square opening of 16 inches by 16 inches, and no more than 20 percent passes through square openings of 8 inches by 8 inches. The Department may allow stones of smaller sizes for filling voids in the upper surface and dressing to the proper slope.
SUBSECTION: 806.03.03 Modification. REVISION: Replace the first sentence with the following: Use only styrene-butadiene (SB) or styrene-butadiene-styrene (SBS) modifiers.
SUBSECTION: 810.02 APPROVAL. REVISION: Replace reference "KM 114" with "KM 115".
SUBSECTION: 810.03.06 Identification and Markings. REVISION: Delete the following text from the first paragraph: "When the manufacturer has more than one plant, include the plant letter assigned by the Division of Materials after the date of manufacture as follows: L-Louisville N-London" Delete the following paragraph: "The Department will not require the certification on the shipment approval form to be notarized. The Department will not require the information under "Pipe Data" on the approval form when the manufacture's shipment ticket is attached and contains the necessary information."
SUBSECTION: 811.02.01 Requirements. REVISION: Replace the subsection with the following: Furnish bar reinforcement for bridges, cast-in-place culverts, and cast-in-place retaining walls that conforms to ASTM A 615 (billet) or ASTM A 996 (rail). ASTM A 706 steel is acceptable with prior approval of the Division of Materials. Do not weld any steel bar reinforcement unless it is ASTM A 706 rebar. The Engineer will accept rail steel bar reinforcement in straight lengths only. Do not use rail steel reinforcement where field bending is allowed or required.
SUBSECTION: 811.09.02 Dowel Bars. REVISION: Replace the reference to "ASTM A 616" with "ASTM A 996" Insert the following sentence between the third and fourth sentence of the first paragraph: Broken or sheared ends are acceptable with prior approval of the Division of Materials.
SUBSECTION: 811.06 BAR MATS. REVISION: Replace the subsection with the following: Conform to ASTM A 184 and fabricate by welding deformed Grade 60 weldable bars.
SUBSECTION: 811.09.02 Dowel Bars. REVISION: Replace the first paragraph with the following: Furnish dowel bars that are plain round bars conforming to ASTM A 706, A 615, A 996, or A 617 with respect to mechanical properties only. Provide either Grade 40, 50 or 60 steel. Saw cut the free ends of the dowels and ensure that they are free of burrs or projections. Broken or sheared ends are acceptable with prior approval of the Division of Materials. Coat dowel bars according to AASHTO M 254 with the following exceptions for Type B coatings:

**Supplemental Specifications to The Standard Specifications
for Road and Bridge Construction, 2004 Edition**
(Effective with the January 19, 2007 Letting)

SUBSECTION:	811.10.02 Epoxy Coating Material.
REVISION:	Replace both the reference to "ASTM D 3963 Annex" and "ASTM D 3963" with "AASHTO M 284".
SUBSECTION:	812.01.02 Hot-Rolled Carbon Steel Sheets and Strip of Structural Quality, Grade 33 (Corrugated Steel Plank for Bridge Floors).
REVISION:	Replace the reference to "ASTM A 570" with "ASTM A 1011"
SUBSECTION:	827.04 SEED.
PART:	1)
REVISION:	Replace with the following: Obtain seed only through registered dealers holding a permit to label seed.
SUBSECTION:	827.04 SEED.
REVISION:	Replace the second paragraph with the following: Do not use seed (grasses, native grasses and legumes) if the seed test date is over 9 months old exclusive of the month tested, or if the limits of noxious weed seed is exceeded.
SUBSECTION:	827.04 SEED.
REVISION:	Replace the last paragraph with the following: Wildflower seed shall not be planted until approved by the Division of Materials
SUBSECTION:	828.02 APPROVAL.
REVISION:	Add the following: The Department will continue to include the masonry coatings on the list contingent upon receiving an annual certification containing the following information: 1) A statement that the masonry coating to be furnished during the particular calendar year is of the same composition as that previously approved for inclusion on the approved list. 2) A statement that the masonry coating conforms to the appropriate requirements of the Kentucky Standard Specifications for Road and Bridge Construction. 3) A statement that notification will be made to the Division of Materials of any changes in composition for review and approval before furnishing the material to projects.
SUBSECTION:	843.01.02 Acceptance Procedures for Non-Specification Fabric.
TABLE:	GRAB STRENGTH PAYMENT REDUCTION
REVISION:	Add the following note: The Department will use the lowest value of MACHINE and CROSS for the reduction calculation.
SUBSECTION:	844.02.01 Fly Ash.
PART:	1)
REVISION:	Delete the last sentence.
SUBSECTION:	844.02.01 Fly Ash.
REVISION:	Replace the subsection with the following: 844.02.01 Fly Ash. Select from the Department's List of Approved Materials for fly ash sources. To be placed on the list, furnish samples and ASTM C 618 test data developed over the previous 3 months, and confirm to the requirements in KM 64-325.

**SPECIAL PROVISION FOR EMBANKMENT AT
BRIDGE END BENT STRUCTURES**

This Special Provision will apply when indicated on the plans or in the proposal. Section references herein are to the Department's 2004 Standard Specifications for Road and Bridge Construction.

1.0 DESCRIPTION. Construct a soil, granular, or rock embankment with granular or cohesive pile core and place structure granular backfill, as the Plans require. Construct the embankment according to the requirements of this Special Provision, the Plans, Standard Drawing RGX 100 and 105, and the 2004 Standard Specifications.

2.0 MATERIALS.

2.1 Granular Embankment. Conform to Subsection 805.10. When Granular Embankment materials are erodible or unstable according to Subsection 805.03.04, use the Special Construction Methods found in 3.2 of the Special Provision.

2.2 Rock Embankment. Provide durable rock from roadway excavation that consists principally of Unweathered Limestone, Durable Shale (SDI equal to or greater than 95 according to KM 64-513), or Durable Sandstone.

2.3 Granular Pile Core. Select a gradation of durable rock to facilitate pile driving that conforms to Subsection 805.11. If granular pile core material hinders pile driving operations, take appropriate means necessary to reach the required pile tip elevation, at no expense to the Department.

2.4 Cohesive Pile Core. Conform to Section 206 of the Standard Specifications and use soil with at least 50 percent passing a No. 4 sieve having a minimum Plasticity Index (PI) of 10. In addition, keep the cohesive pile core free of boulders, larger than 6 inches in any dimension, or any other obstructions, which would interfere with drilling operations. If cohesive pile core material interferes with drilling operations, take appropriate means necessary to maintain excavation stability, at no expense to the Department.

2.5 Structure Granular Backfill. Conform to Subsection 805.11

2.6 Geotextile Fabric. Conform to Type I or Type IV in Section 214 and 843 as required in the plans.

3.0 CONSTRUCTION.

3.1 General. Construct roadway embankments at end bents according to Section 206 and in accordance with the Special Provision, the Plans, and Standard Drawings for the full embankment section. In some instances, granular or rock embankment will be required for embankment construction for stability purposes, but this special provision does not prevent the use of soil when appropriate. Refer to the plans for specific details regarding material requirements for embankment construction.

Place and compact granular or cohesive pile core, soil, granular or rock embankment, and structure granular backfill according to the applicable density requirements for the project. When constructing granular or rock embankments, use granular pile core for driven pile foundations and use cohesive pile core for pre-drilled pile or drilled shaft foundations. Place geotextile fabric, Type IV between cohesive pile core and structure granular backfill and granular or rock embankment.

When granular or rock embankment is required for embankment construction, conform to the general requirements of Subsection 206.03.02 B). In addition, place the material in no greater than 2-foot lifts and compact with a vibrating smooth wheel roller capable of producing a minimum centrifugal force of 15 tons. Apply these requirements to the full width of the embankment for a distance of twice the embankment height or 50 feet, whichever is less, as shown on Standard Drawing RGX-105.

When using granular pile core, install 8-inch perforated underdrain pipe at or near the elevation of the original ground in the approximate locations depicted on the standard drawing, and as the Engineer directs, to ensure positive drainage of the embankment. Wrap the perforated pipe with a fabric of a type recommended by the pipe manufacturer.

After constructing the embankment, excavate for the end bent cap, drive piling or install shafts, place the mortar bed, construct the end bent, and complete the embankment to finish grade according to the construction sequence shown on the Plans or Standard Drawings and as specified hereinafter.

After piles are driven or shafts installed (see design drawings), slope the bottom of the excavation towards the ends of the trench as noted on the plans for drainage. Using a separate pour, place concrete mortar, or any class concrete, to provide a base for forming and placing the cap. Place side forms for the end bent after the mortar has set sufficiently to support workmen and forms without being disturbed.

Install 4-inch perforated pipe in accordance with the plans and Standard Drawings. In the event slope protection extends above the elevation of the perforated pipe, extend the pipe through the slope protection.

After placing the end bent cap and removing adjacent forms, fill the excavation

69

with structure granular backfill material to the level of the berm prior to placing beams for the bridge. For soil embankments, place Type IV geotextile fabric between embankment material and structure granular backfill. After completing the end bent backwall, or after completing the span end wall, place the structure granular backfill to subgrade elevation. If the original excavation is enlarged, fill the entire volume with compacted structure granular backfill at no expense to the Department. Do not place backfill before removing adjacent form work. Place structure granular backfill material in trench ditches at the ends of the excavation. Place Geotextile Fabric, Type IV over the surface of structure granular backfill prior to placing aggregate base course.

Tamp the backfill with hand tampers, pneumatic tampers, or other means the Engineer approves. Thoroughly compact the backfill under the overhanging portions of the structure to ensure that the backfill is in intimate contact with the sides of the structure.

Do not apply seeding, sodding, or other vegetation to the exposed granular embankment.

3.2 Special Construction Methods. Erodible or unstable materials may erode even when protected by riprap or channel lining; use the special construction method described below when using these materials.

Use fine aggregates or friable sandstone granular embankment at “dry land” structures only. Do not use them at stream crossings or locations subject to flood waters.

For erodible or unstable materials having 50 percent or more passing the No. 4 sieve, protect with geotextile fabric. Extend the fabric from the original ground to the top of slope over the entire area of the embankment slopes on each side of, and in front of, the end bent. Cover the fabric with at least 12 inches of non-erodible material.

For erodible or unstable materials having less than 50 percent passing a No. 4 sieve, cover with at least 12 inches of non-erodible material.

Where erodible or unstable granular embankment will be protected by riprap or channel lining, place geotextile fabric between the embankment and the specified slope protection.

4.0 MEASUREMENT.

4.1 Granular Embankment. The Department will measure the quantity in cubic yards using the plan quantity, increased or decreased by authorized adjustments as specified in Section 204. The Department will not measure for payment any Granular Embankment that is not called for in the plans.

The Department will not measure for payment any special construction caused by using erodible or unstable materials and will consider it incidental to the Granular Embankment regardless of whether the erodible or unstable material was

specified or permitted.

4.2 Rock Embankment. The Department will not measure for payment any rock embankment and will consider it incidental to roadway excavation or embankment in place, as applicable. (embankments requiring rock with none present within project excavation limits will be constructed using granular embankment)

4.3 Granular Pile Core. The Department will measure the quantity in cubic yards using the plan quantity, increased or decreased by authorized adjustments as specified in Section 204. The Department will not measure for payment furnishing and placing 8-inch perforated underdrain pipe and will consider it incidental to the Granular pile core. The Department will not measure for payment any granular pile core that is necessary because the contractor elects to use granular or rock embankment when it is not specified in the plans.

4.4 Cohesive Pile Core. The Department will measure the quantity in cubic yards using the plan quantity, increased or decreased by authorized adjustments as specified in Section 204.

4.5 Structure Granular Backfill. The Department will measure the quantity in cubic yards using the plan quantity, increased or decreased by authorized adjustments as specified in Section 204. The Department will not measure any additional material required for backfill outside the limits shown on the Plans and Standard Drawings for payment and will consider it incidental to the work.

When following construction sequence "A", as shown on the Standard Drawings, the Department will not measure structure excavation at the end bent for payment and will consider it incidental to Structure Granular Backfill.

The Department will not measure for payment the 4-inch perforated underdrain pipe and will consider it incidental to the Structure Granular Backfill.

4.4 4.6 Geotextile Fabric. The Department will measure the quantities as specified in Section 214. The Department will not measure the quantity of fabric used for separating granular or rock embankment and cohesive pile core and will consider it incidental to cohesive pile core.

4.7 End Bent. The Department will measure the quantities according to the Contract. The Department will not measure furnishing and placing the 2-inch mortar or concrete bed for payment and will consider it incidental to the end bent construction.

5.0 PAYMENT. The Department will make payment for the completed and

69

accepted quantities under the following:

<u>Code</u>	<u>Pay Item</u>	<u>Pay Unit</u>
2223	Granular Embankment	Cubic Yards
20209EP69	Granular Pile Core	Cubic Yards
20210EP69	Cohesive Pile Core	Cubic Yards
2231	Structure Granular Backfill	Cubic Yards
2596, 2599	Geotextile Fabric, Type	See Section 214

The Department will consider payment as full compensation for all work required in this provision.

January 10, 2005

COUNTY OF	ITEM NO.	SHEET NO.

~NOTES~

1. BREAKAWAY SIGN SUPPORT SYSTEM FOR TYPE C BEAM SHALL BE SELECTED FROM THE KENTUCKY DEPARTMENT OF HIGHWAYS APPROVED LIST FOR BREAKAWAY SIGN SUPPORT SYSTEMS OR AN APPROVED EQUAL. ACCEPTABLE ALTERNATE BREAKAWAY SIGN SUPPORT SYSTEMS SHALL BE APPROVED BY THE DIVISION OF HIGHWAY DESIGN AND FHWA PRIOR TO INSTALLATION.
2. SELECTION OF THE PROPER BRACKET NUMBER SHALL BE IN ACCORDANCE WITH MANUFACTURER'S RECOMMENDATIONS.
3. ALL HARDWARE ITEMS SUPPLIED ARE AMERICAN STANDARD SIZES AND SHALL BE GALVANIZED AND CONFORM TO ASTM A153 OR ASTM B695.
4. FASTENERS, EXCEPT FOR SPECIAL BOLT AND COUPLINGS, ARE INSTALLED WITH LOCKWASHERS, AND DO NOT HAVE SPECIFIC TORQUE REQUIREMENTS. FASTENERS SHALL BE SECURED AS TIGHT AS POSSIBLE WITH CONVENTIONAL WRENCHES, UNLESS NOTED OTHERWISE.
5. SQUARE UP AND LEVEL INDIVIDUAL COMPONENTS, PARTICULARLY ANCHORS TO MINIMIZE THE NEED FOR SHIMMING BETWEEN THE COUPLINGS AND ANCHORS.
6. NO MORE THAN TWO SHIMS SHALL BE PLACED UNDER ANY ONE COUPLING.
7. NO MORE THAN THREE SHIMS UNDERNEATH ANY PAIR OF COUPLINGS.
8. THE CONTRACTOR SHALL FURNISH TWO (2) COMPLETE SETS OF SHOP PLANS FOR APPROVAL BY THE ENGINEER A MINIMUM OF TWO WEEKS PRIOR TO INSTALLATION.
9. THE HINGE SHOULD BE AT LEAST 7'-0" ABOVE THE GROUND.
10. A SINGLE POST IF 7'-0" OR MORE FROM ANOTHER POST, SHALL HAVE A WEIGHT LESS THAN 45 LB./FT. TOTAL WEIGHT BELOW THE HINGE, BUT ABOVE THE SHEAR PLATE OF THE BREAKAWAY BASE, SHOULD NOT EXCEED 600 LB.
11. FOR TWO POSTS SPACED LESS THAN 7'-0" APART, EACH POST SHOULD HAVE A WEIGHT LESS THAN 18 LB./FT. COUPLINGS SHALL NOT BE USED IN SIGN STRUCTURES WITH THREE SUPPORTS OR MORE IF POSTS ARE CLOSER THAN 7'-0" APART.
12. REFER TO DETAIL SHEET "FOOTING DETAILS FOR TYPE C BEAM" FOR FOOTER DETAILS.

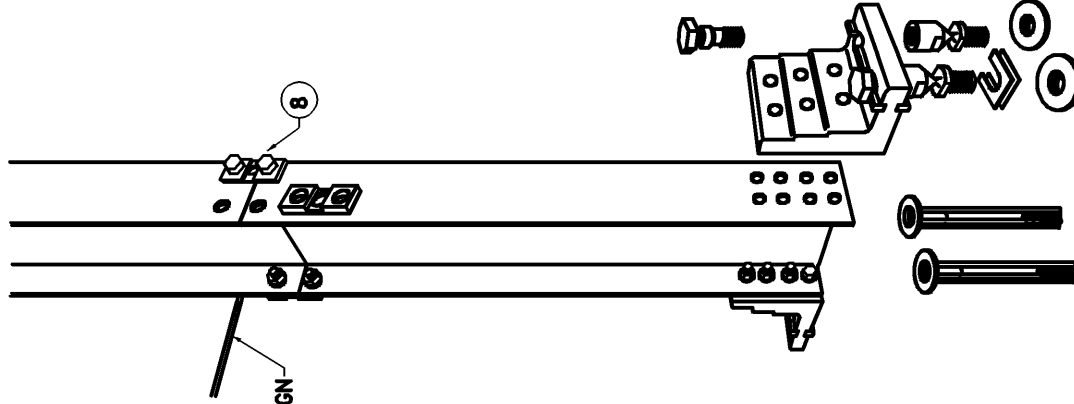

~ PICTORIAL VIEW ~

BRACKET SELECTION TABLE

I-BEAM POST SIZE	BRACKET NO. 1		BRACKET NO. 2		BRACKET NO. 3	
	MIN. "L"	MAX. "L"	MIN. "L"	MAX. "L"	MIN. "L"	MAX. "L"
6"	12'-0"	29'-0"	9'-0"	12'-0"	0	9'-0"
8"	14'-0"	29'-0"	10'-0"	14'-0"	0	10'-0"
10"	16'-0"	29'-0"	11'-0"	16'-0"	0	11'-0"
12"	18'-0"	29'-0"	13'-0"	18'-0"	0	13'-0"
14"	19'-0"	29'-0"	14'-0"	19'-0"	0	14'-0"
16"	21'-0"	29'-0"	15'-0"	21'-0"	0	15'-0"
18"	23'-0"	29'-0"	16'-0"	23'-0"	0	16'-0"
21"	25'-0"	29'-0"	18'-0"	25'-0"	0	18'-0"

$L = L_T - H/2$

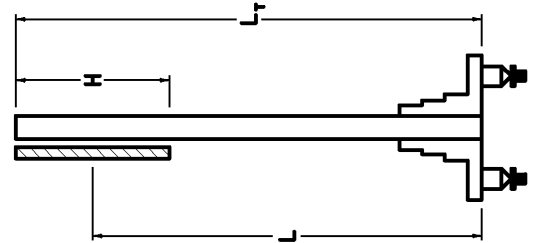

~ ELEVATION VIEW ~

KENTUCKY
DEPARTMENT OF HIGHWAYS

**BREAKAWAY SIGN
SUPPORT SYSTEM
FOR TYPE C BEAM**

Contract ID 070011
89 of 100
6-6-2005
DA 161

SUBMITTED TO: DESIGN

COUNTY OF _____
ITEM NO. _____

SHEET NO. _____
OF _____

FOOTING SELECTION TABLE

POST SIZE	L ₁ DIA.	D ₁ DEPTH	STEEL F. BARS		CONC. CUL YD.
			QTY	SIZE	
W6	2'-0"	5'-0"	5	#4	0.58
W8	2'-6"	7'-0"	7	#4	1.27
W10	3'-0"	8'-0"	8	#4	2.09
W12	3'-0"	8'-0"	8	#4	2.09
W14	3'-0"	9'-0"	9	#4	2.36
W16	3'-6"	9'-0"	9	#4	3.21
W18	3'-5"	9'-0"	9	#4	3.21
W21	4'-0"	9'-0"	9	#4	4.19

~NOTES~

1. ENTER FOOTING SELECTION TABLE WITH REQUIRED POST SIZE AND FIND REQUIRED FOOTING VALUES AS SHOWN IN DETAILS.
2. THE ANCHOR SHALL BE 304 STAINLESS STEEL WITH 1053 STEEL ROD AND COIL.
3. FORM TOP 1'-0" OF THE FOOTING.
4. USE CLASS "A" CONCRETE IN ALL FOOTINGS.
5. ACTUAL DIMENSIONS 'A' & 'B' SHOULD BE OBTAINED FROM THE MANUFACTURER OR MEASURED FROM THE ASSEMBLED BRACKET'S PRIOR TO PLACEMENT OF ANCHORS.
6. TO INSURE PROPER SPACING AND ALIGNMENT OF ANCHORS, IT IS RECOMMENDED THAT ALL ANCHORS BE HELD IN PLACE BY A RIGID TEMPLATE WHILE THE CONCRETE IS PLACED AND CURED.
7. FOOTING PROJECTIONS ABOVE GROUND LINE SHALL BE MINIMIZED. THE MAXIMUM PERMISSIBLE FOOTING PROJECTION SHALL BE 4" ON THE LOWER SLOPE SIDE. WHERE NECESSARY, THE SHADED AREA OF THE FOOTING SHALL BE REMOVED AND REINFORCEMENT SHALL BE BENT TO FIT.
8. THE TOP OF THE FOOTING SHALL NOT PROJECT MORE THAN 4" ABOVE ANY 5'-0" CHORD ALIGNED PERPENDICULAR TO THE EDGE OF THE ROADWAY BETWEEN A POINT ON THE GROUND SURFACE ON ONE SIDE OF THE SUPPORT TO A POINT ON THE GROUND SURFACE ON THE OTHER SIDE OF THE SUPPORT.

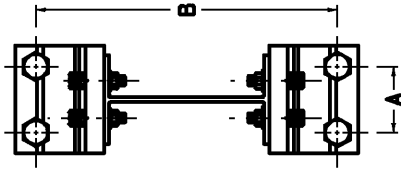
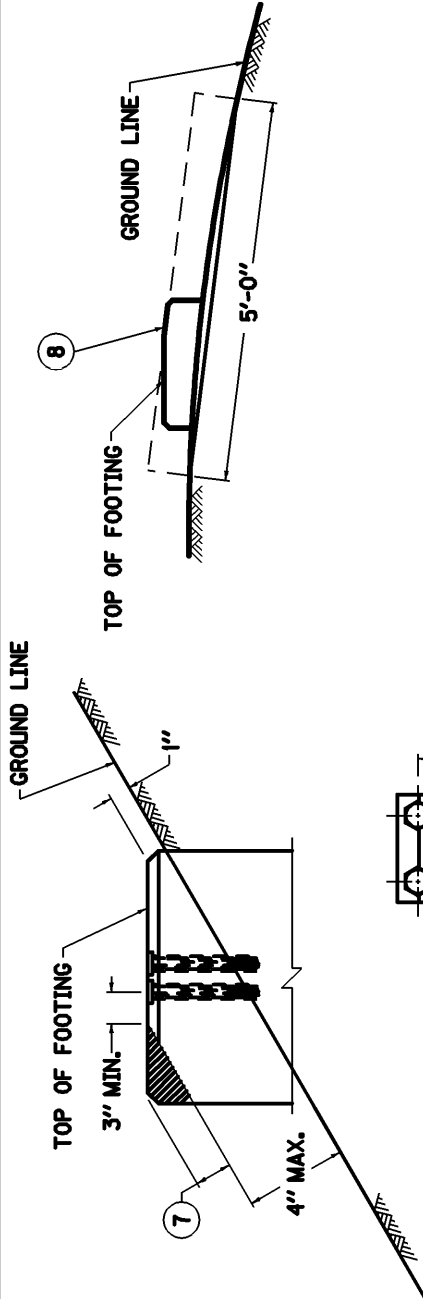

~ PLAN VIEW ~

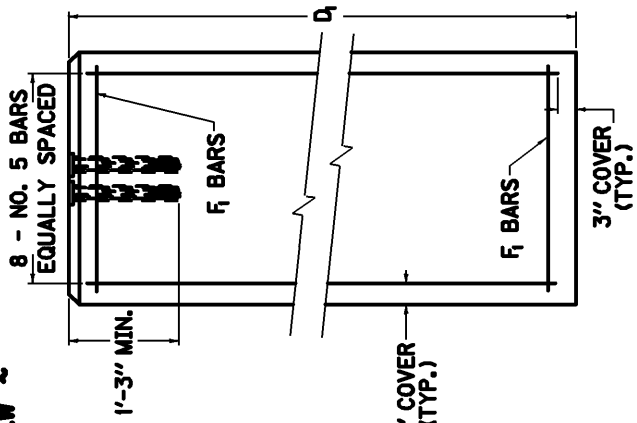

~ SIDE VIEW ~

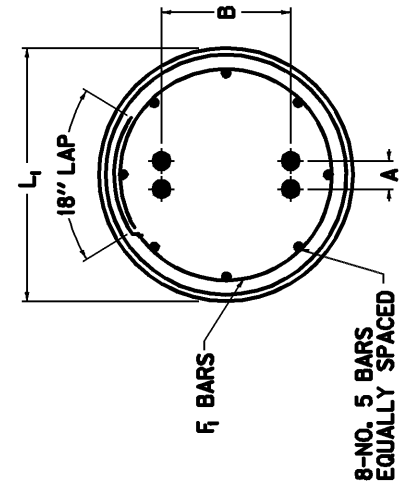

~ TOP VIEW ~

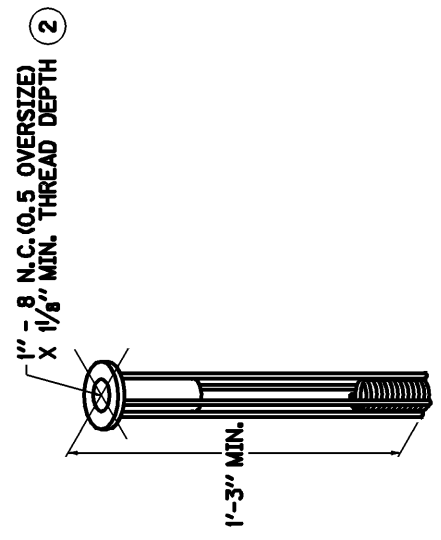

~ ANCHOR PICTORIAL VIEW ~

KENTUCKY
DEPARTMENT OF HIGHWAYS

**FOOTING DETAILS
FOR
TYPE C BEAM**

Contract ID 072011
Page 60 of 61

6-6-2015

TESTED APPROVED DESIGN

SUBMITTED

PART III

EMPLOYMENT, WAGE AND RECORD REQUIREMENTS

Note: The KYTC shall re-submit a right-of-way certification form for this project prior to the start of construction, verifying that fair market value for all parcels has been paid or deposited with the court.

**REQUIRED CONTRACT PROVISIONS
FEDERAL-AID CONSTRUCTION CONTRACTS**

	Page
I. General-----	1
II. Nondiscrimination-----	1
III. Nonsegregated Facilities-----	3
IV. Payment of Predetermined Minimum Wage-----	3
V. Statements and Payrolls-----	6
VI. Record of Materials, Supplies, and Labor-----	6
VII. Subletting or Assigning the Contract-----	7
VIII. Safety: Accident Prevention-----	7
IX. False Statements Concerning Highway Projects-----	7
X. Implementation of Clean Air Act and Federal Water Pollution Control Act-----	8
XI. Certification Regarding Debarment, Suspension, Ineligibility, and Voluntary Exclusion-----	8
XII. Certification Regarding Use of Contract Funds for Lobbying-----	9

ATTACHMENTS

- A. Employment Preference for Appalachian Contracts
(included in Appalachian contracts only)

I. GENERAL

1. These contract provisions shall apply to all work performed on the contract by the contractor's own organization and with the assistance of workers under the contractor's immediate superintendence and to all work performed on the contract by piecework, station work, or by subcontract.

2. Except as otherwise provided for in each section, the contractor shall insert in each subcontract all of the stipulations contained in these Required Contract Provisions, and further require their inclusion in any lower tier subcontract or purchase order that may in turn be made. The Required Contract Provisions shall not be incorporated by reference in any case. The prime contractor shall be responsible for compliance by any subcontractor or lower tier subcontractor with these Required Contract Provisions.

3. A breach of any of the stipulations contained in these Required Contract Provisions shall be sufficient grounds for termination of the contract.

4. A breach of the following clauses of the Required Contract Provisions may also be grounds for debarment as provided in 29 CFR 5.12:

- Section I, paragraph 2;
- Section IV, paragraphs 1, 2, 3, 4, and 7;
- Section V, paragraphs 1 and 2a through 2g.

5. Disputes arising out of the labor standards provisions of Section IV (except paragraph 5) and Section V of these Required Contract Provisions shall not be subject to the general disputes clause of this contract. Such disputes shall be resolved in accordance with the procedures of the U.S. Department of Labor (DOL) as set forth in 29 CFR 5, 6, and 7. Disputes within the meaning of this clause include disputes between the contractor (or any of its subcontractors) and the contracting agency, the DOL, or the contractor's employees or their representatives.

6. **Selection of Labor:** During the performance of this contract, the contractor shall not:

a. discriminate against labor from any other State, possession, or territory of the United States (except for employment preference for Appalachian contracts, when applicable, as specified in Attachment A), or

b. employ convict labor for any purpose within the limits of the project unless it is labor performed by convicts who are on parole, supervised release, or probation.

II. NONDISCRIMINATION

(Applicable to all Federal-aid construction contracts and to all related subcontracts of \$10,000 or more.)

1. **Equal Employment Opportunity:** Equal employment opportunity (EEO) requirements not to discriminate and to take affirmative action to assure equal opportunity as set forth under laws, executive orders, rules, regulations (28 CFR 35, 29 CFR 1630 and 41 CFR 60) and orders of the Secretary of Labor as modified by the provisions prescribed herein, and imposed pursuant to 23 U.S.C. 140 shall constitute the EEO and specific affirmative action standards for the contractor's project activities under this contract. The Equal Opportunity Construction Contract Specifications set forth under 41 CFR 60-4.3 and the provisions of the American Disabilities Act of 1990 (42 U.S.C. 12101 *et seq.*) set forth under 28 CFR 35 and 29 CFR 1630 are incorporated by reference in this contract. In the execution of this contract, the contractor agrees to comply with the following minimum specific requirement activities of EEO:

a. The contractor will work with the State highway agency (SHA) and the Federal Government in carrying out EEO obligations and in their review of his/her activities under the contract.

b. The contractor will accept as his operating policy the following statement:

"It is the policy of this Company to assure that applicants are employed, and that employees are treated during employment, without regard to their race, religion, sex, color, national origin, age or disability. Such action shall include: employment, upgrading, demotion, or transfer; recruitment or recruitment advertising; layoff or termination; rates of pay or other forms of compensation; and selection for training, including apprenticeship, preapprenticeship, and/or on-the-job training."

2. **EEO Officer:** The contractor will designate and make known to the SHA contracting officers an EEO Officer who will have the responsibility for and must be capable of effectively administering and promoting an active contractor program of EEO and who must be assigned adequate authority and responsibility to do so.

3. **Dissemination of Policy:** All members of the contractor's staff who are authorized to hire, supervise, promote, and discharge employees, or who recommend such action, or who are substantially involved in such action, will be made fully cognizant of, and will implement, the contractor's EEO policy and contractual responsibilities to provide EEO in each grade and classification of employment. To ensure that the above agreement will be met, the following actions will be taken as a minimum:

a. Periodic meetings of supervisory and personnel office employees will be conducted before the start of work and then not less often than once every six months, at which time the contractor's EEO policy and its implementation will be reviewed and explained. The meetings will be conducted by the EEO Officer.

b. All new supervisory or personnel office employees will be given a thorough indoctrination by the EEO Officer, covering all major aspects of the contractor's EEO obligations within thirty days following their reporting for duty with the contractor.

c. All personnel who are engaged in direct recruitment for the project will be instructed by the EEO Officer in the contractor's procedures for locating and hiring minority group employees.

d. Notices and posters setting forth the contractor's EEO policy will be placed in areas readily accessible to employees, applicants for employment and potential employees.

e. The contractor's EEO policy and the procedures to implement such policy will be brought to the attention of employees by means of meetings, employee handbooks, or other appropriate means.

4. **Recruitment:** When advertising for employees, the contractor will include in all advertisements for employees the notation: "An Equal Opportunity Employer." All such advertisements will be placed in publications having a large circulation among minority groups in the area from which the project work force would normally be derived.

a. The contractor will, unless precluded by a valid bargaining agreement, conduct systematic and direct recruitment through public and private employee referral sources likely to yield qualified minority group applicants. To meet this requirement, the contractor will identify sources of potential minority group employees, and establish with such identified sources procedures whereby minority group applicants may be referred to the contractor for employment consideration.

b. In the event the contractor has a valid bargaining agreement providing for exclusive hiring hall referrals, he is expected to observe the provisions of that agreement to the extent that the system permits the contractor's compliance with EEO contract provisions. (The DOL has held that where implementation of such agreements have the effect of discriminating against minorities or women, or obligates the contractor to do the same, such implementation violates Executive Order 11246, as amended.)

c. The contractor will encourage his present employees to refer minority group applicants for employment. Information and procedures with regard to referring minority group applicants will be discussed with employees.

5. **Personnel Actions:** Wages, working conditions, and employee benefits shall be established and administered, and personnel actions of every type, including hiring, upgrading, promotion, transfer, demotion, layoff, and termination, shall be taken without regard to race, color, religion, sex, national origin, age or disability. The following procedures shall be followed:

a. The contractor will conduct periodic inspections of project sites to insure that working conditions and employee facilities do not indicate discriminatory treatment of project site personnel.

b. The contractor will periodically evaluate the spread of wages paid within each classification to determine any evidence of discriminatory wage practices.

c. The contractor will periodically review selected personnel actions in depth to determine whether there is evidence of discrimination. Where evidence is found, the contractor will promptly take corrective action. If the review indicates that the discrimination may extend beyond the actions reviewed, such corrective action shall include all affected persons.

d. The contractor will promptly investigate all complaints of alleged discrimination made to the contractor in connection with his obligations under this contract, will attempt to resolve such complaints, and will take appropriate corrective action within a reasonable time. If the investigation indicates that the discrimination may affect persons other than the complainant, such corrective action shall include such other persons. Upon completion of each investigation, the contractor will inform every complainant of all of his avenues of appeal.

6. **Training and Promotion:**

a. The contractor will assist in locating, qualifying, and increasing the skills of minority group and women employees, and applicants for employment.

b. Consistent with the contractor's work force requirements and as permissible under Federal and State regulations, the contractor shall make full use of training programs, i.e., apprenticeship, and on-the-job training programs for the geographical area of contract performance. Where feasible, 25 percent of apprentices or trainees in each occupation shall be in their first year of apprenticeship or training. In the event a special provision for training is provided under this contract, this subparagraph will be superseded as indicated in the special provision.

c. The contractor will advise employees and applicants for employment of available training programs and entrance requirements for each.

d. The contractor will periodically review the training and promotion potential of minority group and women employees and will encourage eligible employees to apply for such training and promotion.

7. **Unions:** If the contractor relies in whole or in part upon unions as a source of employees, the contractor will use his/her best efforts to obtain the cooperation of such unions to increase opportunities for minority groups and women within the unions, and to effect referrals by such unions of minority and female employees. Actions by the contractor either directly or through a contractor's association acting as agent will include the procedures set forth below:

a. The contractor will use best efforts to develop, in cooperation with the unions, joint training programs aimed toward qualifying more minority group members and women for membership in the unions and increasing the skills of minority group employees and women so that they may qualify for higher paying employment.

b. The contractor will use best efforts to incorporate an EEO clause into each union agreement to the end that such union will be contractually bound to refer applicants without regard to their race, color, religion, sex, national origin, age or disability.

c. The contractor is to obtain information as to the referral practices and policies of the labor union except that to the extent such information is within the exclusive possession of the labor union and such labor union refuses to furnish such information to the contractor, the contractor shall so certify to the SHA and shall set forth what efforts have been made to obtain such information.

d. In the event the union is unable to provide the contractor with a reasonable flow of minority and women referrals within the time limit set forth in the collective bargaining agreement, the contractor will, through independent recruitment efforts, fill the employment vacancies without regard to race, color, religion, sex, national origin,

age or disability; making full efforts to obtain qualified and/or qualifiable minority group persons and women. (The DOL has held that it shall be no excuse that the union with which the contractor has a collective bargaining agreement providing for exclusive referral failed to refer minority employees.) In the event the union referral practice prevents the contractor from meeting the obligations pursuant to Executive Order 11246, as amended, and these special provisions, such contractor shall immediately notify the SHA.

8. Selection of Subcontractors, Procurement of Materials and Leasing of Equipment: The contractor shall not discriminate on the grounds of race, color, religion, sex, national origin, age or disability in the selection and retention of subcontractors, including procurement of materials and leases of equipment.

a. The contractor shall notify all potential subcontractors and suppliers of his/her EEO obligations under this contract.

b. Disadvantaged business enterprises (DBE), as defined in 49 CFR 23, shall have equal opportunity to compete for and perform subcontracts which the contractor enters into pursuant to this contract. The contractor will use his best efforts to solicit bids from and to utilize DBE subcontractors or subcontractors with meaningful minority group and female representation among their employees. Contractors shall obtain lists of DBE construction firms from SHA personnel.

c. The contractor will use his best efforts to ensure subcontractor compliance with their EEO obligations.

9. Records and Reports: The contractor shall keep such records as necessary to document compliance with the EEO requirements. Such records shall be retained for a period of three years following completion of the contract work and shall be available at reasonable times and places for inspection by authorized representatives of the SHA and the FHWA.

a. The records kept by the contractor shall document the following:

(1) The number of minority and non-minority group members and women employed in each work classification on the project;

(2) The progress and efforts being made in cooperation with unions, when applicable, to increase employment opportunities for minorities and women;

(3) The progress and efforts being made in locating, hiring, training, qualifying, and upgrading minority and female employees; and

(4) The progress and efforts being made in securing the services of DBE subcontractors or subcontractors with meaningful minority and female representation among their employees.

b. The contractors will submit an annual report to the SHA each July for the duration of the project, indicating the number of minority, women, and non-minority group employees currently engaged in each work classification required by the contract work. This information is to be reported on Form FHWA-1391. If on-the-job training is being required by special provision, the contractor will be required to collect and report training data.

III. NONSEGREGATED FACILITIES

(Applicable to all Federal-aid construction contracts and to all related subcontracts of \$10,000 or more.)

a. By submission of this bid, the execution of this contract or subcontract, or the consummation of this material supply agreement or purchase order, as appropriate, the bidder, Federal-aid construction contractor, subcontractor, material supplier, or vendor, as appropriate, certifies that the firm does not maintain or provide for its employees any segregated facilities at any of its establishments, and that the firm does not permit its employees to perform their services at any location, under its control, where segregated facilities are maintained. The firm agrees that a breach of this certification is a violation of the EEO provisions of this contract. The firm further certifies that no employee will be denied access to adequate facilities on the basis of sex or disability.

b. As used in this certification, the term "segregated facilities" means any waiting rooms, work areas, restrooms and washrooms, restaurants and other eating areas, timeclocks, locker rooms, and other storage or dressing areas, parking lots, drinking fountains, recreation or entertainment areas, transportation, and housing facilities provided for employees which are segregated by explicit directive, or are, in fact, segregated on the basis of race, color, religion, national origin, age or disability, because of habit, local custom, or otherwise. The only exception will be for the disabled when the demands for accessibility override (e.g. disabled parking).

c. The contractor agrees that it has obtained or will obtain identical certification from proposed subcontractors or material suppliers prior to award of subcontracts or consummation of material supply agreements of \$10,000 or more and that it will retain such certifications in its files.

IV. PAYMENT OF PREDETERMINED MINIMUM WAGE

(Applicable to all Federal-aid construction contracts exceeding \$2,000 and to all related subcontracts, except for projects located on roadways classified as local roads or rural minor collectors, which are exempt.)

1. General:

a. All mechanics and laborers employed or working upon the site of the work will be paid unconditionally and not less often than once a week and without subsequent deduction or rebate on any account [except such payroll deductions as are permitted by regulations (29 CFR 3) issued by the Secretary of Labor under the Copeland Act (40 U.S.C. 276c)] the full amounts of wages and bona fide fringe benefits (or cash equivalents thereof) due at time of payment. The payment shall be computed at wage rates not less than those contained in the wage determination of the Secretary of Labor (hereinafter "the wage determination") which is attached hereto and made a part hereof, regardless of any contractual relationship which may be alleged to exist between the contractor or its subcontractors and such laborers and mechanics. The wage determination (including any additional classifications and wage rates conformed under paragraph 2 of this Section IV and the DOL poster (WH-1321) or Form FHWA-1495) shall be posted at all times by the contractor and its subcontractors at the site of the work in a prominent and accessible place where it can be easily seen by the workers. For the purpose of this Section, contributions made or costs reasonably anticipated for bona fide fringe benefits under Section 1(b)(2) of the Davis-Bacon Act (40 U.S.C. 276a) on behalf of laborers or mechanics are considered wages paid to such laborers or mechanics, subject to the provisions of Section IV, paragraph 3b, hereof. Also, for the purpose of this Section, regular contributions made or costs incurred for more than a weekly period (but not less often than quarterly) under plans, funds, or programs, which cover the particular weekly period, are deemed to be constructively made or incurred during such weekly period. Such laborers and mechanics

shall be paid the appropriate wage rate and fringe benefits on the wage determination for the classification of work actually performed, without regard to skill, except as provided in paragraphs 4 and 5 of this Section IV.

b. Laborers or mechanics performing work in more than one classification may be compensated at the rate specified for each classification for the time actually worked therein, provided, that the employer's payroll records accurately set forth the time spent in each classification in which work is performed.

c. All rulings and interpretations of the Davis-Bacon Act and related acts contained in 29 CFR 1, 3, and 5 are herein incorporated by reference in this contract.

2. Classification:

a. The SHA contracting officer shall require that any class of laborers or mechanics employed under the contract, which is not listed in the wage determination, shall be classified in conformance with the wage determination.

b. The contracting officer shall approve an additional classification, wage rate and fringe benefits only when the following criteria have been met:

(1) the work to be performed by the additional classification requested is not performed by a classification in the wage determination;

(2) the additional classification is utilized in the area by the construction industry;

(3) the proposed wage rate, including any bona fide fringe benefits, bears a reasonable relationship to the wage rates contained in the wage determination; and

(4) with respect to helpers, when such a classification prevails in the area in which the work is performed.

c. If the contractor or subcontractors, as appropriate, the laborers and mechanics (if known) to be employed in the additional classification or their representatives, and the contracting officer agree on the classification and wage rate (including the amount designated for fringe benefits where appropriate), a report of the action taken shall be sent by the contracting officer to the DOL, Administrator of the Wage and Hour Division, Employment Standards Administration, Washington, D.C. 20210. The Wage and Hour Administrator, or an authorized representative, will approve, modify, or disapprove every additional classification action within 30 days of receipt and so advise the contracting officer or will notify the contracting officer within the 30-day period that additional time is necessary.

d. In the event the contractor or subcontractors, as appropriate, the laborers or mechanics to be employed in the additional classification or their representatives, and the contracting officer do not agree on the proposed classification and wage rate (including the amount designated for fringe benefits, where appropriate), the contracting officer shall refer the questions, including the views of all interested parties and the recommendation of the contracting officer, to the Wage and Hour Administrator for determination. Said Administrator, or an authorized representative, will issue a determination within 30 days of receipt and so advise the contracting officer or will notify the contracting officer within the 30-day period that additional time is necessary

e. The wage rate (including fringe benefits where appropriate) determined pursuant to paragraph 2c or 2d of this Section IV shall be paid to all workers performing work in the additional classification from the first day on which work is performed in the classification.

3. Payment of Fringe Benefits:

a. Whenever the minimum wage rate prescribed in the contract for a class of laborers or mechanics includes a fringe benefit which is not expressed as an hourly rate, the contractor or subcontractors, as appropriate, shall either pay the benefit as stated in the wage determination or shall pay another bona fide fringe benefit or an hourly case equivalent thereof.

b. If the contractor or subcontractor, as appropriate, does not make payments to a trustee or other third person, he/she may consider as a part of the wages of any laborer or mechanic the amount of any costs reasonably anticipated in providing bona fide fringe benefits under a plan or program, provided, that the Secretary of Labor has found, upon the written request of the contractor, that the applicable standards of the Davis-Bacon Act have been met. The Secretary of Labor may require the contractor to set aside in a separate account assets for the meeting of obligations under the plan or program.

4. Apprentices and Trainees (Programs of the U.S. DOL) and Helpers:

a. Apprentices:

(1) Apprentices will be permitted to work at less than the predetermined rate for the work they performed when they are employed pursuant to and individually registered in a bona fide apprenticeship program registered with the DOL, Employment and Training Administration, Bureau of Apprenticeship and Training, or with a State apprenticeship agency recognized by the Bureau, or if a person is employed in his/her first 90 days of probationary employment as an apprentice in such an apprenticeship program, who is not individually registered in the program, but who has been certified by the Bureau of Apprenticeship and Training or a State apprenticeship agency (where appropriate) to be eligible for probationary employment as an apprentice.

(2) The allowable ratio of apprentices to journeyman-level employees on the job site in any craft classification shall not be greater than the ratio permitted to the contractor as to the entire work force under the registered program. Any employee listed on a payroll at an apprentice wage rate, who is not registered or otherwise employed as stated above, shall be paid not less than the applicable wage rate listed in the wage determination for the classification of work actually performed. In addition, any apprentice performing work on the job site in excess of the ratio permitted under the registered program shall be paid not less than the applicable wage rate on the wage determination for the work actually performed. Where a contractor or subcontractor is performing construction on a project in a locality other than that in which its program is registered, the ratios and wage rates (expressed in percentages of the journeyman-level hourly rate) specified in the contractor's or subcontractor's registered program shall be observed.

(3) Every apprentice must be paid at not less than the rate specified in the registered program for the apprentice's level of progress, expressed as a percentage of the journeyman-level hourly rate specified in the applicable wage determination. Apprentices shall be paid fringe benefits in accordance with the provisions of the apprenticeship program. If the apprenticeship program does not specify fringe benefits, apprentices must be paid the full amount of fringe benefits listed on the wage determination for the applicable

classification. If the Administrator for the Wage and Hour Division determines that a different practice prevails for the applicable apprentice classification, fringes shall be paid in accordance with that determination.

(4) In the event the Bureau of Apprenticeship and Training, or a State apprenticeship agency recognized by the Bureau, withdraws approval of an apprenticeship program, the contractor or subcontractor will no longer be permitted to utilize apprentices at less than the applicable predetermined rate for the comparable work performed by regular employees until an acceptable program is approved.

b. Trainees:

(1) Except as provided in 29 CFR 5.16, trainees will not be permitted to work at less than the predetermined rate for the work performed unless they are employed pursuant to and individually registered in a program which has received prior approval, evidenced by formal certification by the DOL, Employment and Training Administration.

(2) The ratio of trainees to journeyman-level employees on the job site shall not be greater than permitted under the plan approved by the Employment and Training Administration. Any employee listed on the payroll at a trainee rate who is not registered and participating in a training plan approved by the Employment and Training Administration shall be paid not less than the applicable wage rate on the wage determination for the classification of work actually performed. In addition, any trainee performing work on the job site in excess of the ratio permitted under the registered program shall be paid not less than the applicable wage rate on the wage determination for the work actually performed.

(3) Every trainee must be paid at not less than the rate specified in the approved program for his/her level of progress, expressed as a percentage of the journeyman-level hourly rate specified in the applicable wage determination. Trainees shall be paid fringe benefits in accordance with the provisions of the trainee program. If the trainee program does not mention fringe benefits, trainees shall be paid the full amount of fringe benefits listed on the wage determination unless the Administrator of the Wage and Hour Division determines that there is an apprenticeship program associated with the corresponding journeyman-level wage rate on the wage determination which provides for less than full fringe benefits for apprentices, in which case such trainees shall receive the same fringe benefits as apprentices.

(4) In the event the Employment and Training Administration withdraws approval of a training program, the contractor or subcontractor will no longer be permitted to utilize trainees at less than the applicable predetermined rate for the work performed until an acceptable program is approved.

c. Helpers:

Helpers will be permitted to work on a project if the helper classification is specified and defined on the applicable wage determination or is approved pursuant to the conformance procedure set forth in Section IV.2. Any worker listed on a payroll at a helper wage rate, who is not a helper under an approved definition, shall be paid not less than the applicable wage rate on the wagedetermination for the classification of work actually performed.

5. Apprentices and Trainees (Programs of the U.S. DOT):

Apprentices and trainees working under apprenticeship and skill training programs which have been certified by the Secretary of

Transportation as promoting EEO in connection with Federal-aid highway construction programs are not subject to the requirements of paragraph 4 of this Section IV. The straight time hourly wage rates for apprentices and trainees under such programs will be established by the particular programs. The ratio of apprentices and trainees to journeymen shall not be greater than permitted by the terms of the particular program.

6. Withholding:

The SHA shall upon its own action or upon written request of an authorized representative of the DOL withhold, or cause to be withheld, from the contractor or subcontractor under this contract or any other Federal contract with the same prime contractor, or any other Federally-assisted contract subject to Davis-Bacon prevailing wage requirements which is held by the same prime contractor, as much of the accrued payments or advances as may be considered necessary to pay laborers and mechanics, including apprentices, trainees, and helpers, employed by the contractor or any subcontractor the full amount of wages required by the contract. In the event of failure to pay any laborer or mechanic, including any apprentice, trainee, or helper, employed or working on the site of the work, all or part of the wages required by the contract, the SHA contracting officer may, after written notice to the contractor, take such action as may be necessary to cause the suspension of any further payment, advance, or guarantee of funds until such violations have ceased.

7. Overtime Requirements:

No contractor or subcontractor contracting for any part of the contract work which may require or involve the employment of laborers, mechanics, watchmen, or guards (including apprentices, trainees, and helpers described in paragraphs 4 and 5 above) shall require or permit any laborer, mechanic, watchman, or guard in any workweek in which he/she is employed on such work, to work in excess of 40 hours in such workweek unless such laborer, mechanic, watchman, or guard receives compensation at a rate not less than one-and-one-half times his/her basic rate of pay for all hours worked in excess of 40 hours in such workweek.

8. Violation:

Liability for Unpaid Wages; Liquidated Damages: In the event of any violation of the clause set forth in paragraph 7 above, the contractor and any subcontractor responsible thereof shall be liable to the affected employee for his/her unpaid wages. In addition, such contractor and subcontractor shall be liable to the United States (in the case of work done under contract for the District of Columbia or a territory, to such District or to such territory) for liquidated damages. Such liquidated damages shall be computed with respect to each individual laborer, mechanic, watchman, or guard employed in violation of the clause set forth in paragraph 7, in the sum of \$10 for each calendar day on which such employee was required or permitted to work in excess of the standard work week of 40 hours without payment of the overtime wages required by the clause set forth in paragraph 7.

9. Withholding for Unpaid Wages and Liquidated Damages:

The SHA shall upon its own action or upon written request of any authorized representative of the DOL withhold, or cause to be withheld, from any monies payable on account of work performed by the contractor or subcontractor under any such contract or any other Federal contract with the same prime contractor, or any other Federally-assisted contract subject to the Contract Work Hours and Safety Standards Act, which is held by the same prime contractor, such sums as may be determined to be necessary to satisfy any

liabilities of such contractor or subcontractor for unpaid wages and liquidated damages as provided in the clause set forth in paragraph 8 above.

V. STATEMENTS AND PAYROLLS

(Applicable to all Federal-aid construction contracts exceeding \$2,000 and to all related subcontracts, except for projects located on roadways classified as local roads or rural collectors, which are exempt.)

1. Compliance with Copeland Regulations (29 CFR 3):

The contractor shall comply with the Copeland Regulations of the Secretary of Labor which are herein incorporated by reference.

2. Payrolls and Payroll Records:

a. Payrolls and basic records relating thereto shall be maintained by the contractor and each subcontractor during the course of the work and preserved for a period of 3 years from the date of completion of the contract for all laborers, mechanics, apprentices, trainees, watchmen, helpers, and guards working at the site of the work.

b. The payroll records shall contain the name, social security number, and address of each such employee; his or her correct classification; hourly rates of wages paid (including rates of contributions or costs anticipated for bona fide fringe benefits or cash equivalent thereof the types described in Section 1(b)(2)(B) of the Davis Bacon Act); daily and weekly number of hours worked; deductions made; and actual wages paid. In addition, for Appalachian contracts, the payroll records shall contain a notation indicating whether the employee does, or does not, normally reside in the labor area as defined in Attachment A, paragraph 1. Whenever the Secretary of Labor, pursuant to Section IV, paragraph 3b, has found that the wages of any laborer or mechanic include the amount of any costs reasonably anticipated in providing benefits under a plan or program described in Section 1(b)(2)(B) of the Davis Bacon Act, the contractor and each subcontractor shall maintain records which show that the commitment to provide such benefits is enforceable, that the plan or program is financially responsible, that the plan or program has been communicated in writing to the laborers or mechanics affected, and show the cost anticipated or the actual cost incurred in providing benefits. Contractors or subcontractors employing apprentices or trainees under approved programs shall maintain written evidence of the registration of apprentices and trainees, and ratios and wage rates prescribed in the applicable programs.

c. Each contractor and subcontractor shall furnish, each week in which any contract work is performed, to the SHA resident engineer a payroll of wages paid each of its employees (including apprentices, trainees, and helpers, described in Section IV, paragraphs 4 and 5, and watchmen and guards engaged on work during the preceding weekly payroll period). The payroll submitted required to be maintained under paragraph 2b of this Section V. This information may be submitted in any form desired. Optional Form WH-347 is available for this purpose and may be purchased from the Superintendent of Documents (Federal stock number 029-005-0014-1), U.S. Government Printing Office, Washington, D.C. 20402. The prime contractor is responsible for the submission of copies of payrolls by all subcontractors.

d. Each payroll submitted shall be accompanied by a "Statement of Compliance," signed by the contractor or subcontractor or his/her agent who pays or supervises the payment of the persons employed under the contract and shall certify the following:

(1) that the payroll for the payroll period contains the information required to be maintained under paragraph 2b of this Section V and that such information is correct and complete;

(2) that such laborer or mechanic (including each helper, apprentice, and trainee) employed on the contract during the payroll period has been paid the full weekly wages earned, without rebate, either directly or indirectly, and that no deductions have been made either directly or indirectly from the full wages earned, other than permissible deductions as set forth in the Regulations, 29 CFR 3;

(3) that each laborer or mechanic has been paid not less than the applicable wage rate and fringe benefits or cash equivalent for the classification of worked performed, as specified in the applicable wage determination incorporated into the contract.

e. The weekly submission of a properly executed certification set forth on the reverse side of Optional Form WH-347 shall satisfy the requirement for submission of the "Statement of Compliance" required by paragraph 2d of this Section V.

f. The falsification of any of the above certifications may subject the contractor to civil or criminal prosecution under 18 U.S.C. 1001 and 31 U.S.C. 231.

g. The contractor or subcontractor shall make the records required under paragraph 2b of this Section V available for inspection, copying, or transcription by authorized representatives of the SHA, the FHWA, or the DOL, and shall permit such representatives to interview employees during working hours on the job. If the contractor or subcontractor fails to submit the required records or to make them available, the SHA, the FHWA, the DOL, or all may, after written notice to the contractor, sponsor, applicant, or owner, take such actions as may be necessary to cause the suspension of any further payment, advance, or guarantee of funds. Furthermore, failure to submit the required records upon request or to make such records available may be grounds for debarment action pursuant to 29 CFR 5.12.

VI. RECORD OF MATERIALS, SUPPLIES, AND LABOR

1. On all Federal-aid contracts on the National Highway System, except those which provide solely for the installation of protective devices at railroad grade crossings, those which are constructed on a force account or direct labor basis, highway beautification contracts, and contracts for which the total final construction cost for roadway and bridge is less than \$1,000,000 (23 CFR 635) the contractor shall:

a. Become familiar with the list of specific materials and supplies contained in Form FHWA-47, "Statement of Materials and Labor Used by Contractor of Highway Construction Involving Federal Funds," prior to the commencement of work under this contract.

b. Maintain a record of the total cost of all materials and supplies purchased for and incorporated in the work, and also of the quantities of those specific materials and supplies listed on Form FHWA-47, and in the units shown on Form FHWA-47.

c. Furnish, upon the completion of the contract, to the SHA resident engineer on Form FHWA-47 together with the data required in paragraph 1b relative to materials and supplies, a final labor summary of all contract work indicating the total hours worked and the total amount earned.

2. At the prime contractor's option, either a single report covering all contract work or separate reports for the contractor and for each subcontract shall be submitted.

VII. SUBLETTING OR ASSIGNING THE CONTRACT

1. The contractor shall perform with its own organization contract work amounting to not less than 30 percent (or a greater percentage if specified elsewhere in the contract) of the total original contract price, excluding any specialty items designated by the State. Specialty items may be performed by subcontract and the amount of any such specialty items performed may be deducted from the total original contract price before computing the amount of work required to be performed by the contractor's own organization (23 CFR 635).

a. "Its own organization" shall be construed to include only workers employed and paid directly by the prime contractor and equipment owned or rented by the prime contractor, with or without operators. Such term does not include employees or equipment of a subcontractor, assignee, or agent of the prime contractor.

b. "Specialty Items" shall be construed to be limited to work that requires highly specialized knowledge, abilities, or equipment not ordinarily available in the type of contracting organizations qualified and expected to bid on the contract as a whole and in general are to be limited to minor components of the overall contract.

2. The contract amount upon which the requirements set forth in paragraph 1 of Section VII is computed includes the cost of material and manufactured products which are to be purchased or produced by the contractor under the contract provisions.

3. The contractor shall furnish (a) a competent superintendent or supervisor who is employed by the firm, has full authority to direct performance of the work in accordance with the contract requirements, and is in charge of all construction operations (regardless of who performs the work) and (b) such other of its own organizational resources (supervision, management, and engineering services) as the SHA contracting officer determines is necessary to assure the performance of the contract.

4. No portion of the contract shall be sublet, assigned or otherwise disposed of except with the written consent of the SHA contracting officer, or authorized representative, and such consent when given shall not be construed to relieve the contractor of any responsibility for the fulfillment of the contract. Written consent will be given only after the SHA has assured that each subcontract is evidenced in writing and that it contains all pertinent provisions and requirements of the prime contract.

VIII. SAFETY: ACCIDENT PREVENTION

1. In the performance of this contract the contractor shall comply with all applicable Federal, State, and local laws governing safety, health, and sanitation (23 CFR 635). The contractor shall provide all safeguards, safety devices and protective equipment and take any other needed actions as it determines, or as the SHA contracting officer may determine, to be reasonably necessary to protect the life and health of employees on the job and the safety of the public and to protect property in connection with the performance of the work covered by the contract.

2. It is a condition of this contract, and shall be made a condition of each subcontract, which the contractor enters into pursuant to this contract, that the contractor and any subcontractor shall not permit any employee, in performance of the contract, to work in surroundings or under conditions which are unsanitary, hazardous or dangerous to his/her health or safety, as determined under construction safety and health standards (29 CFR 1926) promulgated by the Secretary of Labor, in accordance with Section 107 of the Contract Work Hours and Safety Standards Act (40 U.S.C. 333).

3. Pursuant to 29 CFR 1926.3, it is a condition of this contract that the Secretary of Labor or authorized representative thereof, shall have right of entry to any site of contract performance to inspect or investigate the matter of compliance with the construction safety and health standards and to carry out the duties of the Secretary under Section 107 of the Contract Work Hours and Safety Standards Act (40 U.S.C. 333).

IX. FALSE STATEMENTS CONCERNING HIGHWAY PROJECTS

In order to assure high quality and durable construction in conformity with approved plans and specifications and a high degree of reliability on statements and representations made by engineers, contractors, suppliers, and workers on Federal-aid highway projects, it is essential that all persons concerned with the project perform their functions as carefully, thoroughly, and honestly as possible. Willful falsification, distortion, or misrepresentation with respect to any facts related to the project is a violation of Federal law. To prevent any misunderstanding regarding the seriousness of these and similar acts, the following notice shall be posted on each Federal-aid highway project (23 CFR 635) in one or more places where it is readily available to all persons concerned with the project:

NOTICE TO ALL PERSONNEL ENGAGED ON FEDERAL-AID HIGHWAY PROJECTS

18 U.S.C. 1020 reads as follows:

"Whoever, being an officer, agent, or employee of the United States, or of any State or Territory, or whoever, whether a person, association, firm, or corporation, knowingly makes any false statement, false representation, or false report as to the character, quality, quantity, or cost of the material used or to be used, or the quantity or quality of the work performed or to be performed, or the cost thereof in connection with the submission of plans, maps, specifications, contracts, or costs of construction on any highway or related project submitted for approval to the Secretary of Transportation; or

Whoever knowingly makes any false statement, false representation, false report or false claim with respect to the character, quality, quantity, or cost of any work performed or to be performed, or materials furnished or to be furnished, in connection with the construction of any highway or related project approved by the Secretary of Transportation; or

Whoever knowingly makes any false statement or false representation as to material fact in any statement, certificate, or report submitted pursuant to provisions of the Federal-aid Roads Act approved July 1, 1916, (39 Stat. 355), as amended and supplemented;

Shall be fined not more than \$10,000 or imprisoned not more than 5 years or both."

X. IMPLEMENTATION OF CLEAN AIR ACT AND FEDERAL WATER POLLUTION CONTROL ACT

(Applicable to all Federal-aid construction contracts and to all related subcontracts of \$100,000 or more.)

By submission of this bid or the execution of this contract, or subcontract, as appropriate, the bidder, Federal-aid construction contractor, or subcontractor, as appropriate, will be deemed to have stipulated as follows:

1. That any facility that is or will be utilized in the performance of this contract, unless such contract is exempt under the Clean Air Act, as amended (42 U.S.C. 1857 et seq., as amended by Pub.L. 91-604), and under the Federal Water Pollution Control Act, as amended (33 U.S.C. 1251 et seq., as amended by Pub.L. 92-500), Executive Order 11738, and regulations in implementation thereof (40 CFR 15) is not listed, on the date of contract award, on the U.S. Environmental Protection Agency (EPA) List of Violating Facilities pursuant to 40 CFR 15.20.

2. That the firm agrees to comply and remain in compliance with all the requirements of Section 114 of the Clean Air Act and Section 308 of the Federal Water Pollution Control Act and all regulations and guidelines listed thereunder.

3. That the firm shall promptly notify the SHA of the receipt of any communication from the Director, Office of Federal Activities, EPA, indicating that a facility that is or will be utilized for the contract is under consideration to be listed on the EPA List of Violating Facilities.

4. That the firm agrees to include or cause to be included the requirements of paragraph 1 through 4 of this Section X in every nonexempt subcontract, and further agrees to take such action as the government may direct as a means of enforcing such requirements.

XI. CERTIFICATION REGARDING DEBARMENT, SUSPENSION, INELIGIBILITY AND VOLUNTARY EXCLUSION

1. Instructions for Certification - Primary Covered Transactions:

(Applicable to all Federal-aid contracts - 49 CFR 29)

a. By signing and submitting this proposal, the prospective primary participant is providing the certification set out below.

b. The inability of a person to provide the certification set out below will not necessarily result in denial of participation in this covered transaction. The prospective participant shall submit an explanation of why it cannot provide the certification set out below. The certification or explanation will be considered in connection with the department or agency's determination whether to enter into this transaction. However, failure of the prospective primary participant to furnish a certification or an explanation shall disqualify such a person from participation in this transaction.

c. The certification in this clause is a material representation of fact upon which reliance was placed when the department or agency determined to enter into this transaction. If it is later determined that the prospective primary participant knowingly rendered an erroneous certification, in addition to other remedies available to the Federal Government, the department or agency may terminate this transaction for cause of default.

d. The prospective primary participant shall provide immediate written notice to the department or agency to whom this proposal is submitted if any time the prospective primary participant learns that its certification was erroneous when submitted or has become erroneous by reason of changed circumstances.

e. The terms "covered transaction," "debarred," "suspended," "ineligible," "lower tier covered transaction," "participant," "person," "primary covered transaction," "principal," "proposal," and "voluntarily excluded," as used in this clause, have the meanings set out in the Definitions and Coverage sections of rules implementing Executive Order 12549. You may contact the department or agency to which

this proposal is submitted for assistance in obtaining a copy of those regulations.

f. The prospective primary participant agrees by submitting this proposal that, should the proposed covered transaction be entered into, it shall not knowingly enter into any lower tier covered transaction with a person who is debarred, suspended, declared ineligible, or voluntarily excluded from participation in this covered transaction, unless authorized by the department or agency entering into this transaction.

g. The prospective primary participant further agrees by submitting this proposal that it will include the clause titled "Certification Regarding Debarment, Suspension, Ineligibility and Voluntary Exclusion-Lower Tier Covered Transaction," provided by the department or agency entering into this covered transaction, without modification, in all lower tier covered transactions and in all solicitations for lower tier covered transactions.

h. A participant in a covered transaction may rely upon a certification of a prospective participant in a lower tier covered transaction that is not debarred, suspended, ineligible, or voluntarily excluded from the covered transaction, unless it knows that the certification is erroneous. A participant may decide the method and frequency by which it determines the eligibility of its principals. Each participant may, but is not required to, check the nonprocurement portion of the "Lists of Parties Excluded From Federal Procurement or Nonprocurement Programs" (Nonprocurement List) which is compiled by the General Services Administration.

i. Nothing contained in the foregoing shall be construed to require establishment of a system of records in order to render in good faith the certification required by this clause. The knowledge and information of participant is not required to exceed that which is normally possessed by a prudent person in the ordinary course of business dealings.

j. Except for transactions authorized under paragraph f of these instructions, if a participant in a covered transaction knowingly enters into a lower tier covered transaction with a person who is suspended, debarred, ineligible, or voluntarily excluded from participation in this transaction, in addition to other remedies available to the Federal Government, the department or agency may terminate this transaction for cause or default.

* * * * *

Certification Regarding Debarment, Suspension, Ineligibility and Voluntary Exclusion--Primary Covered Transactions

1. The prospective primary participant certifies to the best of its knowledge and belief, that it and its principals:

a. Are not presently debarred, suspended, proposed for debarment, declared ineligible, or voluntarily excluded from covered transactions by any Federal department or agency;

b. Have not within a 3-year period preceding this proposal been convicted of or had a civil judgement rendered against them for commission of fraud or a criminal offense in connection with obtaining, attempting to obtain, or performing a public (Federal, State or local) transaction or contract under a public transaction; violation of Federal or State antitrust statutes or commission of embezzlement, theft, forgery, bribery, falsification or destruction of records, making false statements, or receiving stolen property;

c. Are not presently indicted for or otherwise criminally or civilly charged by a governmental entity (Federal, State or local) with commission of any of the offenses enumerated in paragraph 1b of this certification; and

d. Have not within a 3-year period preceding this application/proposal had one or more public transactions (Federal, State or local) terminated for cause or default.

2. Where the prospective primary participant is unable to certify to any of the statements in this certification, such prospective participant shall attach an explanation to this proposal.

2. Instructions for Certification - Lower Tier Covered Transactions:

(Applicable to all subcontracts, purchase orders and other lower tier transactions of \$25,000 or more - 49 CFR 29)

a. By signing and submitting this proposal, the prospective lower tier is providing the certification set out below.

b. The certification in this clause is a material representation of fact upon which reliance was placed when this transaction was entered into. If it is later determined that the prospective lower tier participant knowingly rendered an erroneous certification, in addition to other remedies available to the Federal Government, the department, or agency with which this transaction originated may pursue available remedies, including suspension and/or debarment.

c. The prospective lower tier participant shall provide immediate written notice to the person to which this proposal is submitted if at any time the prospective lower tier participant learns that its certification was erroneous by reason of changed circumstances.

d. The terms "covered transaction," "debarred," "suspended," "ineligible," "primary covered transaction," "participant," "person," "principal," "proposal," and "voluntarily excluded," as used in this clause, have the meanings set out in the Definitions and Coverage sections of rules implementing Executive Order 12549. You may contact the person to which this proposal is submitted for assistance in obtaining a copy of those regulations.

e. The prospective lower tier participant agrees by submitting this proposal that, should the proposed covered transaction be entered into, it shall not knowingly enter into any lower tier covered transaction with a person who is debarred, suspended, declared ineligible, or voluntarily excluded from participation in this covered transaction, unless authorized by the department or agency with which this transaction originated.

f. The prospective lower tier participant further agrees by submitting this proposal that it will include this clause titled "Certification Regarding Debarment, Suspension, Ineligibility and Voluntary Exclusion-Lower Tier Covered Transaction," without modification, in all lower tier covered transactions and in all solicitations for lower tier covered transactions.

g. A participant in a covered transaction may rely upon a certification of a prospective participant in a lower tier covered transaction that is not debarred, suspended, ineligible, or voluntarily excluded from the covered transaction, unless it knows that the certification is erroneous. A participant may decide the method and frequency by which it determines the eligibility of its principals. Each participant may, but is not required to, check the Nonprocurement List.

h. Nothing contained in the foregoing shall be construed to require establishment of a system of records in order to render in good faith the certification required by this clause. The knowledge and information of participant is not required to exceed that which is normally possessed by a prudent person in the ordinary course of business dealings.

i. Except for transactions authorized under paragraph e of these instructions, if a participant in a covered transaction knowingly enters into a lower tier covered transaction with a person who is suspended, debarred, ineligible, or voluntarily excluded from participation in this transaction, in addition to other remedies available to the Federal Government, the department or agency with which this transaction originated may pursue available remedies, including suspension and/or debarment.

Certification Regarding Debarment, Suspension, Ineligibility and Voluntary Exclusion--Lower Tier Covered Transactions:

1. The prospective lower tier participant certifies, by submission of this proposal, that neither it nor its principals is presently debarred, suspended, proposed for debarment, declared ineligible, or voluntarily excluded from participation in this transaction by any Federal department or agency.

2. Where the prospective lower tier participant is unable to certify to any of the statements in this certification, such prospective participant shall attach an explanation to this proposal.

XII. CERTIFICATION REGARDING USE OF CONTRACT FUNDS FOR LOBBYING

(Applicable to all Federal-aid construction contracts and to all related subcontracts which exceed \$100,000 - 49 CFR 20)

1. The prospective participant certifies, by signing and submitting this bid or proposal, to the best of his or her knowledge and belief, that:

a. No Federal appropriated funds have been paid or will be paid, by or on behalf of the undersigned, to any person for influencing or attempting to influence an officer or employee of any Federal agency, a Member of Congress, an officer or employee of Congress, or an employee of a Member of Congress in connection with the awarding of any Federal contract, the making of any Federal grant, the making of any Federal loan, the entering into of any cooperative agreement, and the extension, continuation, renewal, amendment, or modification of any Federal contract, grant, loan, or cooperative agreement.

b. If any funds other than Federal appropriated funds have been paid or will be paid to any person for influencing or attempting to influence an officer or employee of any Federal agency, a Member of Congress, an officer or employee of Congress, or an employee of a Member of Congress in connection with this Federal contract, grant, loan, or cooperative agreement, the undersigned shall complete and

submit Standard Form-LLL, "Disclosure Form to Report Lobbying," in accordance with its instructions.

2. This certification is a material representation of fact upon which reliance was placed when this transaction was made or entered into. Submission of this certification is a prerequisite for making or entering into this transaction imposed by 31 U.S.C. 1352. Any person who fails to file the required certification shall be subject to a civil penalty of not less than \$10,000 and not more than \$100,000 for each such failure.

3. The prospective participant also agrees by submitting his or her bid or proposal that he or she shall require that the language of this certification be included in all lower tier subcontracts, which exceed \$100,000 and that all such recipients shall certify and disclose accordingly.

**KENTUCKY TRANSPORTATION CABINET
DEPARTMENT OF HIGHWAYS**

**EMPLOYMENT REQUIREMENTS
RELATING TO
NONDISCRIMINATION OF EMPLOYEES
(APPLICABLE TO FEDERAL-AID SYSTEM CONTRACTS)**

**AN ACT OF THE KENTUCKY GENERAL ASSEMBLY
TO PREVENT DISCRIMINATION IN EMPLOYMENT**

**KRS CHAPTER 344
EFFECTIVE JUNE 16, 1972**

The contract on this project, in accordance with KRS Chapter 344, provides that during the performance of this contract, the contractor agrees as follows:

1. The contractor shall not fail or refuse to hire, or shall not discharge any individual, or otherwise discriminate against an individual with respect to his compensation, terms, conditions, or privileges of employment, because of such individual's race, color, religion, national origin, sex, disability or age (between forty and seventy); or limit, segregate, or classify his employees in any way which would deprive or tend to deprive an individual of employment opportunities or otherwise adversely affect his status as an employee, because of such individual's race, color, religion, national origin, sex, disability or age (between forty and seventy). The contractor agrees to post in conspicuous places, available to employees and applicants for employment, notices to be provided setting forth the provisions of this nondiscrimination clause.

2. The contractor shall not print or publish or cause to be printed or published a notice or advertisement relating to employment by such an employer or membership in or any classification or referral for employment by the employment agency, indicating any preference, limitation, specification, or discrimination, based on race, color, religion, national origin, sex, disability or age (between forty and seventy), except that such notice or advertisement may indicate a preference, limitation, or specification based on religion, or national origin when religion, or national origin is a bona fide occupational qualification for employment.

3. If the contractor is in control of apprenticeship or other training or retraining, including on-the-job training programs, he shall not discriminate against an individual because of his race, color, religion, national origin, sex, disability or age (between forty and seventy), in admission to, or employment in any program established to

provide apprenticeship or other training.

4. The contractor will send to each labor union or representative of workers with which he has a collective bargaining agreement or other contract or understanding, a notice to be provided advising the said labor union or workers' representative of the contractor's commitments under this section, and shall post copies of the notice in conspicuous places available to employees and applicants for employment. The contractor will take such action with respect to any subcontract or purchase order as the administering agency may direct as a means of enforcing such provisions, including sanctions for non-compliance.

REVISED: 12-3-92

EXECUTIVE BRANCH CODE OF ETHICS

In the 1992 regular legislative session, the General Assembly passed and Governor Brereton Jones signed Senate Bill 63 (codified as KRS 11A), the Executive Branch Code of Ethics, which states, in part:

KRS 11A.040 (6) provides:

No present or former public servant shall, within six (6) months of following termination of his office or employment, accept employment, compensation or other economic benefit from any person or business that contracts or does business with the state in matters in which he was directly involved during his tenure. This provision shall not prohibit an individual from returning to the same business, firm, occupation, or profession in which he was involved prior to taking office or beginning his term of employment, provided that, for a period of six (6) months, he personally refrains from working on any matter in which he was directly involved in state government. This subsection shall not prohibit the performance of ministerial functions, including, but not limited to, filing tax returns, filing applications for permits or licenses, or filing incorporation papers.

KRS 11A.040 (8) states:

A former public servant shall not represent a person in a matter before a state agency in which the former public servant was directly involved, for a period of one (1) year after the latter of:

- a) The date of leaving office or termination of employment; or
- b) The date the term of office expires to which the public servant was elected.

This law is intended to promote public confidence in the integrity of state government and to declare as public policy the idea that state employees should view their work as a public trust and not as a way to obtain private benefits.

If you have worked for the executive branch of state government within the past six months, you may be subject to the law's prohibitions. The law's applicability may be different if you hold elected office or are contemplating representation of another before a state agency.

Also, if you are affiliated with a firm which does business with the state and which employs former state executive-branch employees, you should be aware that the law may apply to them.

In case of doubt, the law permits you to request an advisory opinion from the Executive Branch Ethics Commission, Room 136, Capitol Building, 700 Capitol Avenue, Frankfort, Kentucky 40601; telephone (502) 564-7954.

**TRANSPORTATION CABINET
DIVISION OF CONSTRUCTION PROCUREMENT
COMPLIANCE SECTION
PROJECT WAGE RATES**

HIGHWAY BASIC HOURLY RATES	FRINGE BENEFIT PAYMENTS COMBINED
---	---

CRAFTS:

Ballard, Butler, Caldwell, Carlisle, Crittenden, Daviess, Edmonson, Fulton, Graves, Hancock, Henderson, Hickman, Hopkins, Livingston, Lyon, Marshall, McCracken, McLean, Muhlenberg, Ohio, Union & Webster Counties:

Bricklayers25.25.....10.20

Allen, Calloway, Christian, Logan, Simpson, Todd, Trigg & Warren Counties:

Bricklayers25.10.....1.60

All Counties:

Carpenters23.60.....8.97

Divers35.78.....8.97

Piledrivermen23.85.....8.97

Butler, Edmonson, Logan, Todd & Warren Counties:

Electricians25.91.....23.5% + 4.55

Allen & Simpson Counties:

Electricians15.85.....4.115

Ballard, Caldwell, Calloway, Carlisle, Christian, Crittenden, Fulton (Except a 5 mile radius of City Hall in Fulton), Graves, Hickman, Livingston, Lyon, Marshall, McCracken & Trigg Counties:

Electricians:

Electricians26.57.....24% + 5.15

Cable Splicers26.32.....24% + 5.15

Daviess, Hancock, Henderson, Hopkins, McLean, Muhlenberg, Ohio, Union & Webster Counties:

Electricians:

Electricians25.12.....26.125% + 5.35

Heilarc Welding & Cable Splicing25.37.....26.125% + 5.35

Fulton County (Up to a 5 mile radius of City Hall in Fulton):

Electricians18.50.....9.99

Cable Splicers19.00.....9.99

Butler County (Eastern eighth, including the Townships of Decker, Lee & Tilford);

Edmonson County (Northern three-fourths, including the Townships of Asphalt, Bee Spring, Brownsville, Grassland, Huff, Kyrock, Lindseyville, Mammoth Cave, Ollie, Prosperity, Rhoda, Sunfish & Sweden):

Ironworkers:

Structural; Ornamental; Reinforcing;

Precast Concrete Erectors23.49.....14.80

**TRANSPORTATION CABINET
DIVISION OF CONSTRUCTION PROCUREMENT
COMPLIANCE SECTION
PROJECT WAGE RATES**

HIGHWAY BASIC HOURLY RATES	FRINGE BENEFIT PAYMENTS COMBINED
---	---

CRAFTS: (continued)

Butler County (Townships of Aberdeen, Bancock, Casey, Dexterville, Dunbar, Elfie, Gilstrap, Huntsville, Logansport, Monford, Morgantown, Provo, Rochester, and South Hill & Welchs Creek); Caldwell County (Northeastern third, including the Township of Creswell); Christian County (Northern third, including Townships of Apex, Crofton, Kelly, Mannington and Wynns); Crittenden County (Northeastern half, including the Townships of Grove, Mattoon, Repton, Shady Grove and Tribune); Muhlenberg County (Townships of Bavier, Beech Creek Junction, Benton, Brennen, Browder, Central City, Cleaton, Depoy, Drakesboro, Eunis, Graham, Hillside, Luzerne, Lynn City, Martwick, McNary, Moorman, Millport, Nelson, Paradise, Powderly, South Carrollton, Tarina and Weir);

Daviess, Hancock, Henderson, Hopkins, McLean, Ohio, Union and Webster Counties:

Ironworkers	23.50.....	12.475
-------------------	------------	--------

Butler County (Southern third, including the Townships of Boston, Berrys Lick, Dimple, Jetson, Quality, Sharer, Sugar Grove and Woodbury);

Christian County (Eastern two-thirds, including the Townships of Bennettstown, Casky, Herndon, Hopkinsville, Howell, Masonville, Pembroke and Thompsonville);

Edmonson County (Southern fourth, including the Townships of Chalybeate & Rocky Hill);

Muhlenberg County (Southern eighth, including the Townships of Dunnior, Penrod & Rosewood);

Allen, Logan, Simpson, Todd and Warren Counties:

Ironworkers	19.58.....	8.57
-------------------	------------	------

Caldwell County (Southwestern two-thirds, including the Townships of Cedar Bluff, Cider, Claxton, Cobb, Crowtown, Dulaney, Farmersville, Fredonia, McGowan, Otter Pond and Princeton);

Christian County (Western third, excluding the Townships of Apex, Crofton, Kelly, Mannington, Wynns, Bennettstown, Casky, Herndon, Hopkinsville, Howell, Masonville, Pembroke and Thompsonville);

Crittenden County (Southwestern half, including the Townships of Crayne, Dycusburg, Frances, Marion, Mexico, Midway, Sheridan and Told);

Ballard, Calloway, Carlisle, Fulton, Graves, Hickman, Livingston, Lyon, Marshall, McCracken and Trigg Counties:

Ironworkers

Projects with a total contract cost of \$20,000,000.00 or above

.....	23.50.....	13.55
-------	------------	-------

All other work.....	22.20.....	12.49
---------------------	------------	-------

Allen, Butler, Edmonson, Logan, Simpson & Warren Counties:

Millwrights.....	23.25.....	13.52
------------------	------------	-------

**TRANSPORTATION CABINET
DIVISION OF CONSTRUCTION PROCUREMENT
COMPLIANCE SECTION
PROJECT WAGE RATES**

HIGHWAY BASIC HOURLY RATES	FRINGE BENEFIT PAYMENTS COMBINED
---	---

CRAFTS: (continued)

Ballard, Caldwell, Calloway, Carlisle, Christian, Crittenden, Fulton, Graves, Hickman, Hopkins, Livingston, Lyon, Marshall, McCracken, Todd & Trigg Counties:

Millwrights:.....	21.75.....	12.68
-------------------	------------	-------

Daviess, Hancock, Henderson, McLean, Muhlenberg, Ohio, Union & Webster Counties:

Millwrights:.....	21.83.....	12.75
-------------------	------------	-------

Ballard County:

Painters:

Bridges and Dams	27.09.....	10.18
------------------------	------------	-------

All Other Work	22.79.....	10.18
----------------------	------------	-------

Spray, Blast, Steam, High and Hazardous (Including Lead Abatement) and All Epoxy – 1.00 Premium.

Edmonson County:

Painters:

Brush & Roller	17.37.....	8.32
----------------------	------------	------

Spray, Sandblast, Power Tools, Waterblast & Steam Cleaning.....	17.87.....	8.32
--	------------	------

Daviess, Hancock, Henderson, McLean, Ohio, Union & Webster Counties:

Painters:

Bridges, Locks & Dams:

GROUP 1	24.00.....	9.48
---------------	------------	------

GROUP 2	24.25.....	9.48
---------------	------------	------

GROUP 3	25.00.....	9.48
---------------	------------	------

GROUP 4	26.00.....	9.48
---------------	------------	------

All Other Work:

GROUP 1	22.85.....	9.48
---------------	------------	------

GROUP 2	23.10.....	9.48
---------------	------------	------

GROUP 3	23.85.....	9.48
---------------	------------	------

GROUP 4	24.85.....	9.48
---------------	------------	------

PAINTER CLASSIFICATIONS

GROUP 1 – Brush & Roller

GROUP 2 – Plasterers

GROUP 3 – Spray; Sandblast; Power Tools; Waterblast; Steamcleaning; Brush & Roller of Mastics, Creosotes, Kwinch Koate & Coal Tar Epoxy

GROUP 4 – Spray of Mastics, Creosotes, Kwinch Koate & Coal Tar Epoxy

**TRANSPORTATION CABINET
DIVISION OF CONSTRUCTION PROCUREMENT
COMPLIANCE SECTION
PROJECT WAGE RATES**

HIGHWAY BASIC HOURLY RATES	FRINGE BENEFIT PAYMENTS COMBINED
Allen, Butler, Logan, Muhlenberg, Simpson, Todd & Warren Counties:	
Painters:	
Bridges, Locks & Dams	
Brush & Roller	21.03 6.80
Bridges, Locks & Dams	
Spray; Sandblast; Power Tools; Waterblast & Steam	
Cleaning	22.03 6.80
All Other Work	
Brush & Roller	17.03 6.80
All Other Work	
Spray; Sandblast; Power Tools; Waterblast & Steam	
Cleaning	18.03 6.80
All Other Work – High Time Pay	
Over 35 feet (up to 100 feet) - \$1.00 above base wage	
100 feet and over - \$2.00 above base wage	
During spray painting and sandblasting operations, pot tenders shall receive the same wage rates as the spray painter or nozzle operator	
Caldwell, Calloway, Carlisle, Christian, Crittenden, Fulton, Graves, Hickman, Hopkins, Livingston, Lyon, Marshall, McCracken & Trigg Counties:	
Painters:	
Bridges and Dams	24.00 8.30
All Other Work	17.75 8.30
Waterblasting units with 3500 PSI and above - \$.50 premium	
Spraypainting and all abrasive blasting - \$1.00 premium	
Work 40 ft. and above ground level - \$1.00 premium	
Allen, Butler, Edmonson, Simpson, Warren Counties:	
Plumber/Pipefitter	27.20 12.47
Ballard, Caldwell, Calloway, Carlisle, Christian, Crittenden, Fulton, Graves, Hickman, Livingston, Lyon, Marshall, McCracken & Trigg Counties:	
Plumbers & Steamfitters	26.33 12.05
Allen, Butler, Edmonson, Simpson & Warren Counties:	
Plumbers & Steamfitters	27.20 12.47
Daviss, Hancock, Henderson, Hopkins, Logan, McLean, Muhlenberg, Ohio, Todd, Union & Webster Counties:	
Plumbers & Pipefitters	25.42 8.85
Welders - Receive rate for craft in which welding is incidental.	

**TRANSPORTATION CABINET
DIVISION OF CONSTRUCTION PROCUREMENT
COMPLIANCE SECTION
PROJECT WAGE RATES**

LABORERS:

Ballard, Calloway, Carlisle, Fulton, Graves, Hickman, Livingston, Lyon, Marshall and McCracken Counties:

GROUP 1 - Aging & curing of concrete, asbestos abatement worker, asphalt plant, asphalt, batch truck dump, carpenter tender, cement mason tender, cleaning of machines, concrete, demolition, dredging, environmental -nuclear radiation, toxic & hazardous waste - Level D, flagperson, grade checker, hand digging & hand back filling, highway marker placer, landscaping, mesh handler & placer, puddler, railroad, rip-rap & grouter, right-of-way, sign, guard rail & fence installer, signal person, sound barrier installer, storm & sanitary sewer, swamper, truck spotter & dumper & wrecking of concrete forms, general cleanup.

BASE RATE.....18.40
FRINGE BENEFITS9.21

GROUP 2 - Batter board man (sanitary & storm sewer), brickmason tender, mortar mixer operator, scaffold builder, burner & welder, bushhammer, chain saw operator, concrete saw operator, deckhand scow man, dry cement handler, environmental - nuclear, radiation, toxic & hazardous waste - Level C, forklift operator for masonry, form setter, green concrete cutting, hand operated grouter & grinder machine operator, jackhammer, pavement breaker, paving joint machine, pipelayer, plastic pipe fusion, power driven georgia buggy & wheel barrow, power post hole digger, precast manhole setter, walk-behind tamper, walk-behind trencher, sand blaster, concrete chipper, surface grinder, vibrator operator and wagon driller.

BASE RATE.....18.65
FRINGE BENEFITS9.21

GROUP 3 - Asphalt luteman & raker, gunnite nozzleman, gunnite operator & mixer, grout pump operator, blaster, side rail setter, rail paved ditches, screw operator, tunnel (free air), and water blaster .

BASE RATE.....18.70
FRINGE BENEFITS9.21

GROUP 4 - Caisson worker (free air), cement finisher, environmental - nuclear, radiation, toxic & hazardous waste - levels A & B, miner & driller (free air), tunnel blaster and tunnel mucker (free air), directional & horizontal boring, air track drillers (all types), powderman & blasters, troxler & concrete tester if laborer is utilized.

BASE RATE.....19.30
FRINGE BENEFITS9.21

**TRANSPORTATION CABINET
DIVISION OF CONSTRUCTION PROCUREMENT
COMPLIANCE SECTION
PROJECT WAGE RATES**

LABORERS:

Allen, Butler, Caldwell, Christian, Daviess, Edmonson, Hancock, Hopkins, Logan, McLean, Muhlenberg, Ohio Simpson, Todd, Trigg and Warren Counties;

GROUP 1 - Aging & curing of concrete, asbestos abatement worker, asphalt plant, asphalt, batch truck dump, carpenter tender, cement mason tender, cleaning of machines, concrete, demolition, dredging, environmental -nuclear radiation, toxic & hazardous waste - Level D, flagperson, grade checker, hand digging & hand back filling, highway marker placer, landscaping, mesh handler & placer, puddler, railroad, rip-rap & grouter, right-of-way, sign, guard rail & fence installer, signal person, sound barrier installer, storm & sanitary sewer, swamper, truck spotter & dumper & wrecking of concrete forms, general cleanup.

BASE RATE.....19.18
FRINGE BENEFITS8.43

GROUP 2 - Batter board man (sanitary & storm sewer), brickmason tender, mortar mixer operator, scaffold builder, burner & welder, bushhammer, chain saw operator, concrete saw operator, deckhand scow man, dry cement handler, environmental - nuclear, radiation, toxic & hazardous waste - Level C, forklift operator for masonry, form setter, green concrete cutting, hand operated grouter & grinder machine operator, jackhammer, pavement breaker, paving joint machine, pipelayer, plastic pipe fusion, power driven georgia buggy & wheel barrow, power post hole digger, precast manhole setter, walk-behind tamper, walk-behind trencher, sand blaster, concrete chipper, surface grinder, vibrator operator and wagon driller.

BASE RATE.....19.43
FRINGE BENEFITS8.43

GROUP 3 - Asphalt luteman & raker, gunnite nozzleman, gunnite operator & mixer, grout pump operator, blaster, side rail setter, rail paved ditches, screw operator, tunnel (free air), and water blaster .

BASE RATE.....19.48
FRINGE BENEFITS8.43

GROUP 4 - Caisson worker (free air), cement finisher, environmental - nuclear, radiation, toxic & hazardous waste - levels A & B, miner & driller (free air), tunnel blaster and tunnel mucker (free air), directional & horizontal boring, air track drillers (all types), powderman & blasters, troxler & concrete tester if laborer is utilized.

BASE RATE.....20.08
FRINGE BENEFITS8.43

**TRANSPORTATION CABINET
DIVISION OF CONSTRUCTION PROCUREMENT
COMPLIANCE SECTION
PROJECT WAGE RATES**

LABORERS:

Crittenden, Henderson, Union and Webster Counties:

GROUP 1 - Aging & curing of concrete, asbestos abatement worker, asphalt plant, asphalt, batch truck dump, carpenter tender, cement mason tender, cleaning of machines, concrete, demolition, dredging, environmental -nuclear radiation, toxic & hazardous waste - Level D, flagperson, grade checker, hand digging & hand back filling, highway marker placer, landscaping, mesh handler & placer, puddler, railroad, rip-rap & grouter, right-of-way, sign, guard rail & fence installer, signal person, sound barrier installer, storm & sanitary sewer, swamper, truck spotter & dumper & wrecking of concrete forms, general cleanup.

BASE RATE19.56
FRINGE BENEFITS8.05

GROUP 2 - Batter board man (sanitary & storm sewer), brickmason tender, mortar mixer operator, scaffold builder, burner & welder, bushhammer, chain saw operator, concrete saw operator, deckhand scow man, dry cement handler, environmental - nuclear, radiation, toxic & hazardous waste - Level C, forklift operator for masonry, form setter, green concrete cutting, hand operated grouter & grinder machine operator, jackhammer, pavement breaker, paving joint machine, pipelayer, plastic pipe fusion, power driven georgia buggy & wheel barrow, power post hole digger, precast manhole setter, walk-behind tamper, walk-behind trencher, sand blaster, concrete chipper, surface grinder, vibrator operator and wagon driller.

BASE RATE19.81
FRINGE BENEFITS8.05

GROUP 3 - Asphalt lutean & raker, gunnite nozzleman, gunnite operator & mixer, grout pump operator, blaster, side rail setter, rail paved ditches, screw operator, tunnel (free air), and water blaster .

BASE RATE19.86
FRINGE BENEFITS8.05

GROUP 4 - Caisson worker (free air), cement finisher, environmental - nuclear, radiation, toxic & hazardous waste - levels A & B, miner & driller (free air), tunnel blaster and tunnel mucker (free air), directional & horizontal boring, air track drillers (all types), powderman & blasters, troxler & concrete tester if laborer is utilized.

BASE RATE20.08
FRINGE BENEFITS8.05

**TRANSPORTATION CABINET
DIVISION OF CONSTRUCTION PROCUREMENT
COMPLIANCE SECTION
PROJECT WAGE RATES**

TEAMSTERS:

Truck Drivers:

Allen, Butler, Edmonson, Logan, Simpson & Warren Counties:

Greaser, tire changer.

BASE RATE17.54
FRINGE BENEFITS10.84

Truck Mechanic.

BASE RATE17.87
FRINGE BENEFITS10.84

Single Axle Dump, Flat Bed, all Terrain vehicles when used to haul materials, Semi Trailer or Pole Trailer when used to pull building materials and equipment, Tandem Axle Dump, Driver of Distributors, Mixer all types.

BASE RATE17.94
FRINGE BENEFITS10.84

Winch and A-frame when used in transporting materials, Ross Carrier, Fork Lift when used to transport building materials, Driver on Pavement Breaker.

BASE RATE17.95
FRINGE BENEFITS10.84

Euclid and other Heavy Earth Moving Equipment, Low Boy, Articulator Cat, Five Axle Vehicle.

BASE RATE18.00
FRINGE BENEFITS10.84

Ballard, Calloway, Caldwell, Carlisle, Christian, Crittenden, Fulton, Graves, Hickman, Livingston, Lyon, Marshall, McCracken, Todd & Trigg Counties:
Greaser, Tire Changer.

BASE RATE23.89
FRINGE BENEFITS4.15

Truck Mechanic.

BASE RATE24.12
FRINGE BENEFITS4.15

**TRANSPORTATION CABINET
DIVISION OF CONSTRUCTION PROCUREMENT
COMPLIANCE SECTION
PROJECT WAGE RATES**

TEAMSTERS: (continue)

Single Axle Dump, Flat Bed, all Terrain vehicles when used to haul materials, Semi Trailer or Pole Trailer when used to pull building materials and equipment, Tandem Axle Dump, Driver of Distributor, Mixer all types.

BASE RATE24.19
FRINGE BENEFITS4.15

Euclid, other Heavy Earth Moving Equipment, Low Boy, Articulator Cat, Five Axle Vehicle, Winch & A-Frame when used in transporting materials, Ross Carrier.

BASE RATE24.20
FRINGE BENEFITS4.15

Daviess, Hancock, Henderson, Hopkins, McLean, Muhlenberg, Ohio, Union & Webster Counties: Greaser, Tire Changer.

BASE RATE19.23
FRINGE BENEFITS9.20

Truck Mechanic.

BASE RATE19.46
FRINGE BENEFITS9.20

Single Axle Dump, Flat Bed, all Terrain Vehicle when used to haul materials, Semi Trailer or Pole Trailer when used to pull building materials and equipment, Tandem Axle Dump, Driver of Distributors, Mixer all types.

BASE RATE19.53
FRINGE BENEFITS9.20

Euclid and other Heavy Earth Moving Equipment, Low Boy, Articulator Cat, Five Axle Vehicle, Winch & A-Frame when used in transporting materials, Ross Carrier, Fork Lift when used to transport building materials, Driver on Pavement Breaker.

BASE RATE19.54
FRINGE BENEFITS9.20

**TRANSPORTATION CABINET
DIVISION OF CONSTRUCTION PROCUREMENT
COMPLIANCE SECTION
PROJECT WAGE RATES**

OPERATING ENGINEERS:

A-frame Winch Truck, Auto Patrol, Backfiller, Batcher Plant, Bituminous Paver, Bituminous Transfer Machine, Boom Cat, Bulldozer, Mechanic, Cableway, Carry-All Scoop, Carry Deck Crane, Central Compressor Plant, Clamshell, Concrete Mixer (21 cu. ft. or over), Concrete Paver, Truck Mounted Concrete Pump, Core Drill, Crane, Crusher Plant, Derrick, Derrick Boat, Ditching and Trenching Machine, Dragline, Dredge Operator, Dredge Engineer, Elevating Grader and Loaders, Grade-All, Gurries, Heavy Equipment Robotics Operator/Mechanic, High Lift, Hoe-Type Machine, Hoist (two or more drums), Hoisting Engine (two or more drums), Horizontal Directional Drill Operator, Hydrocrane, Hyster, KeCal Loader, LeTourneau, Locomotive, Mechanic; Mechanically Operated Laser Screed, Mechanic Welder, Mucking Machine, Motor scraper, Orangepeel Bucket, Piledriver, Power Blade, Pumpcrete, Push Dozer, Rock Spreader attached to equipment, Rotary Drill, Roller (bituminous), Scarifier, Scoopmobile, Shovel, Side Boom, Subgrader, Tailboom, Telescoping type Forklift, Tow or Push boat, Tower Crane (French, German and other types), Tractor Shovel, Truck Crane, Tunnel Mining Machines, including Moles, Shields or similar types of Tunnel Mining Equipment.

BASE RATE22.95
FRINGE BENEFITS11.90

Air Compressor (over 900 cu. ft. per min.), Bituminous Mixer, Boom Type Tamping Machine, Bull Float, Concrete Mixer (under 21 cu. ft.), Dredge Engineer, Electric Vibrator, Compactor/Self-Propelled Compactor, Elevator (one drum or buck hoist), Elevator (when used to hoist building material), Finish Machine, Firemen & Hoist (one drum), Flexplane, Forklift (regardless of lift height), Form Grader, Joint Sealing Machine, Outboard Motor Boat, Power Sweeper (riding type), Roller (rock), Ross Carrier, Skid Mounted or Trailer Mounted Concrete Pump, Skid Steer Machine with all attachments, Switchman or Brakeman, Throttle Valve Person, Tractair and Road Widening Trencher, Tractor (50 H.P. or over), Truck Crane Oiler, Tugger, Welding Machine, Well Points, and Whirley Oiler.

BASE RATE20.53
FRINGE BENEFITS11.90

All off road material handling equipment, including Articulating Dump Trucks, Greaser on grease facilities servicing heavy equipment.

BASE RATE20.91
FRINGE BENEFITS11.90

**TRANSPORTATION CABINET
DIVISION OF CONSTRUCTION PROCUREMENT
COMPLIANCE SECTION
PROJECT WAGE RATES**

OPERATING ENGINEERS: (continued)

Bituminous Distributor, Burlap and Curing Machine, Cement Gun, Concrete Saw, Conveyor, Deckhand Oiler, Grout Pump, Hydraulic Post Driver, Hydro Seeder, Mud Jack, Oiler, Paving Joint Machine, Power Form handling equipment, Pump, Roller (earth), Steerman, Tamping Machine, Tractor (under 50 H.P.) and Vibrator.

BASE RATE20.27
FRINGE BENEFITS11.90

Cranes - with booms 150 ft. and over (including jib), and where the length of the Boom in combination with the length of the piling equals or exceeds 150 ft. - \$1.00 above Group 1 rate.

Employees assigned to work below ground level are to be paid 10% above basic wage rate. This does not apply to open cut work.

Fringe benefit amounts are applicable for all hours worked except when otherwise noted.

These rates are listed pursuant to the Kentucky Determination No. CR-05-I HWY dated May 16, 2006 and/or Federal Decision No. KY20070025 dated February 9, 2007 and modification #1 dated February 16, 2007.

**TRANSPORTATION CABINET
DIVISION OF CONSTRUCTION PROCUREMENT
COMPLIANCE SECTION
PROJECT WAGE RATES**

No laborer, workman or mechanic shall be paid at a rate less than that of a Journeyman except those classified as bona fide apprentices.

Apprentices or trainees shall be permitted to work as such subject to Administrative Regulations adopted by the Commissioner of Workplace Standards. Copies of these regulations will be furnished upon request from any interested person.

Before using apprentices on the job the contractor shall present to the Contracting Officer written evidence of registration of such employees in a program of a State apprenticeship and training agency approved and recognized by the U. S. Bureau of Apprenticeship and Training. In the absence of such a State agency, the contractor shall submit evidence of approval and registration by the U. S. Bureau of Apprenticeship and Training.

The contractor shall submit to the Contracting Officer, written evidence of the established apprenticeship-journeyman ratios and wage rates in the project area, which will be the basis for establishing such ratios and rates for the project under the applicable contract provisions.

TO: EMPLOYERS/EMPLOYEES

PREVAILING WAGE SCHEDULE:

The wages indicated on this wage schedule are the least permitted to be paid for the occupations indicated. When an employee works in more than one classification, the employer must record the number of hours worked in each classification at the prescribed hourly base rate.

OVERTIME:

Overtime is to be paid after an employee works eight (8) hours a day or forty (40) hours a week, whichever gives the employee the greater wages. At least time and one-half the base rate is required for all overtime. A laborer, workman or mechanic and an employer may enter into a written agreement or a collective bargaining agreement to work more than eight (8) hours a calendar day but not more than ten (10) hours a calendar day for the straight time hourly rate.

Wage violations or questions should be directed to the designated Engineer or the undersigned.

Steve Waddle, Director
Division of Construction Procurement
Frankfort, Kentucky 40622

**NOTICE OF REQUIREMENT FOR AFFIRMATIVE ACTION
TO ENSURE EQUAL EMPLOYMENT OPPORTUNITY
(Executive Order 11246)**

1. The Offeror's or Bidder's attention is called to the "Equal Opportunity Clause" and the "Standard Federal Equal Employment Specifications" set forth herein.
2. The goals and timetables for minority and female participation, expressed in percentage terms for the Contractor's aggregate work force in each trade on all construction work in the covered area, are as follows:

GOALS FOR MINORITY PARTICIPATION IN EACH TRADE	GOALS FOR FEMALE PARTICIPATION IN EACH TRADE
18.2%	6.9%

These goals are applicable to all the Contractor's construction work (whether or not it is Federal or federally-assisted) performed in the covered area. If the contractor performs construction work in a geographical area located outside of the covered area, it shall apply the goals established for such geographical area where the work is actually performed. With regard to this second area, the contractor also is subject to the goals for both its federally involved and non-federally involved construction.

The Contractor's compliance with the Executive Order and the regulations in CFR Part 60-4 shall be based on its implementation of the Equal Opportunity Clause, specific affirmative action obligations required by the specifications set forth in 41 CFR 60-4, 3(a), and its efforts to meet the goals. The hours of minority and female employment and training must be substantially uniform throughout the length of the contract, and in each trade, and the contractor shall make a good faith effort to employ minorities and women evenly on each of its projects. The transfer of minority or female employees or trainees from Contractor to Contractor or from project to project for the sole purpose of meeting the Contractor's goals shall be a violation of the contract, the Executive Order and the regulations in 41 CFR Part 60-4. Compliance with the goals will be measured against the total work hours performed.

3. The Contractor shall provide written notification to the Director of the Office of Federal Contract Compliance Programs within ten (10) working days of award of any construction subcontract in excess of \$10,000.00 at any tier for construction work under the contract resulting from this solicitation. The notification shall list the name, address and telephone number of the subcontractor; employer identification number of the subcontractor; estimated dollar amount of the subcontract; estimated starting and completion dates of the subcontract; and the geographical area in which the subcontract is to be performed. The notification shall be mailed to:

**Evelyn Teague, Regional Director
Office of Federal Contract Compliance Programs
61 Forsyth Street, SW, Suite 7B75
Atlanta, Georgia 30303-8609**

4. As used in this Notice, and in the contract resulting from this solicitation, the "**covered area**" is Christian County.

PART IV
INSURANCE

INSURANCE

The Contractor shall carry the following insurance in addition to the insurance required by law:

1. Contractor's Public Liability Insurance not less than \$100,000.00 for damages arising out of bodily injuries to or death to one person. Not less than \$300,000.00 for damages arising out of bodily injuries to or death to two or more persons.
2. Contractor's Property Damages Liability Insurance. Not less than \$100,000.00 for all damages arising out of injury or destruction of property in any one accident. Not less than \$300,000.00 for all damages during the policy period.
3. Contractor's Protective Public Liability and Property Damage Insurance. The contractor shall furnish evidence with respect to operations performed for him by subcontractors that he carries in his own behalf for the above stipulated amounts.
4. The insurance required above must be evidenced by a Certificate of Insurance and this Certificate of Insurance must contain one of the following statements:
 - a. "policy contains no deductible clauses."
 - b. "policy contains _____ (amount) deductible property damage clause but company will pay claim and collect the deductible from the insured."
5. WORKMEN'S COMPENSATION INSURANCE. The contractor shall furnish evidence of coverage of all his employees or give evidence of self-insurance by submitting a copy of a certificate issued by the Workmen's Compensation Board.

PART V

STATEMENT OF INCOMPLETE WORK

STATEMENT OF INCOMPLETED WORK

All active prime contracts must be reported. This includes prime contracts with public and private owners and joint-ventured contracts. The names of the joint venturers must be shown when reporting these projects. A machine or typed listing reporting the status of each contract is acceptable when attached to this report; however, the total amounts on the itemized listing must be reported in the space provided below:

CONTRACT WITH	PROJECT IDENTIFICATION	PRIME CONTRACT AMOUNT	EARNINGS THROUGH LAST APPROVED ESTIMATE	TOTAL AMOUNT OF WORK REMAINING
TOTAL (Attach Summary if not itemized above)		\$	\$	\$

PART VI

BID ITEMS

TRANSPORTATION CABINET

Department of Highways

FRANKFORT, KY 40622

Sheet No: 1

Contract ID: 07-1211

CHRISTIAN COUNTY

BRZ 0203 (289)

Letting: 3/23/07

THE BIDDER MUST MAKE THE EXTENSIONS AND ADDITIONS
SHOWING TOTAL AMOUNT BID USING FIGURES ONLY

Item No.	Code No.	Item	Approximate Quantity	Unit	Unit Price Dollars	Amount Dollars
		ROADWAY			.	.
0010	00001	DGA BASE	5,958.00	TON	.	.
0020	00071	CRUSHED AGGREGATE SIZE NO 57	3,461.00	TON	.	.
0030	00100	ASPHALT SEAL AGGREGATE	106.00	TON	.	.
0040	00291	EMULSIFIED ASPHALT RS-2	13.00	TON	.	.
0050	02014	BARRICADE-TYPE III	2.00	EACH	.	.
0060	02159	TEMPORARY DITCH	284.00	LF	.	.
0070	02230	EMBANKMENT IN PLACE	319.00	CUYD	.	.
0080	02351	GUARDRAIL-STEEL W BEAM-S FACE	250.00	LF	.	.
0090	02360	GUARDRAIL TERMINAL SECTION NO 1	1.00	EACH	.	.
0100	02371	GUARDRAIL END TREATMENT TYPE 7	3.00	EACH	.	.
0110	02483	CHANNEL LINING CLASS II	76.70	TON	.	.
0120	02484	CHANNEL LINING CLASS III	188.00	TON	.	.
0130	02545	CLEARING AND GRUBBING .24 ACRES	1.00	LS	.	.
0140	02562	SIGNS	194.00	SQFT	.	.
0150	02599	FABRIC-GEOTEXTILE TYPE IV	200.00	SQYD	.	.
0160	02650	MAINTAIN & CONTROL TRAFFIC	1.00	LS	.	.
0170	02701	TEMPORARY SILT FENCE	278.00	LF	.	.
0180	02704	SILT TRAP TYPE B	3.00	EACH	.	.
0190	02707	CLEAN SILT TRAP TYPE B	6.00	EACH	.	.
0200	02709	CLEAN TEMPORARY SILT FENCE	556.00	LF	.	.
0210	02726	STAKING	1.00	LS	.	.
0220	05950	EROSION CONTROL BLANKET	1,175.00	SQYD	.	.
0230	05952	TEMPORARY MULCH	2,350.00	SQYD	.	.
0240	05966	TOPDRESSING FERTILIZER	0.06	TON	.	.
0250	05985	SEEDING AND PROTECTION	1,175.00	SQYD	.	.

TRANSPORTATION CABINET

Department of Highways

FRANKFORT, KY 40622

Sheet No: 2

Contract ID: 07-1211

CHRISTIAN COUNTY

BRZ 0203 (289)

Letting: 3/23/07

THE BIDDER MUST MAKE THE EXTENSIONS AND ADDITIONS
SHOWING TOTAL AMOUNT BID USING FIGURES ONLY

Item No.	Code No.	Item	Approximate Quantity	Unit	Unit Price Dollars	Amount Dollars
0260	10020NS	FUEL ADJUSTMENT	1,451.00	DOLL	1.0000	1,451.00
0270	20209EP69	GRANULAR PILE CORE	65.30	CUYD	.	.
0280	20496NS843	SILT TRAP TYPE C	1.00	EACH	.	.
0290	20497NS843	CLEAN SILT TRAP TYPE C	2.00	EACH	.	.
0300	20588NC	INSTALL PROJECT IDENTIFICATION SIGNS	2.00	EACH	.	.
		BRIDGE			.	.
0310	02231	STRUCTURE GRANULAR BACKFILL	84.00	CUYD	.	.
0320	02998	MASONRY COATING	331.00	SQYD	.	.
0330	03299	ARMORED EDGE FOR CONCRETE	44.00	LF	.	.
0340	08019	CYCLOPEAN STONE RIP RAP	313.00	TON	.	.
0350	08033	TEST PILES	49.00	LF	.	.
0360	08046	PILES-STEEL HP12X53	169.00	LF	.	.
0370	08094	PILE POINTS-12 INCH	10.00	EACH	.	.
0380	08100	CONCRETE-CLASS A	21.40	CUYD	.	.
0390	08104	CONCRETE-CLASS AA	77.20	CUYD	.	.
0400	08151	STEEL REINFORCEMENT-EPOXY COATED	14,130.00	LB	.	.
0410	08671	PRECAST PC BOX BEAM SB33	342.00	LF	.	.
0420	21532ED	RAIL SYSTEM TYPE III	174.00	LF	.	.
		DEMOBILIZATION			.	.
0430	02569	DEMOBILIZATION	1.00	LS	.	.
TOTAL BID					\$.

PART VII
CERTIFICATIONS

PROVISIONS RELATIVE TO SENATE BILL 258 (1994)

During the performance of the contract, the contractor agrees to comply with applicable provisions of:

1. KRS 136 Corporation and Utility Taxes
2. KRS 139 Sale and Use Taxes
3. KRS 141 Income Taxes
4. KRS 337 Wages and Hours
5. KRS 338 Occupational Safety and Health of Employees
6. KRS 341 Unemployment Compensation
7. KRS 342 Workers Compensation

Any final determinations of a violation by the contractor within the previous five (5) years pursuant to the applicable statutes above are revealed as follows:

NON-COLLUSION CERTIFICATION

COMMONWEALTH OF KENTUCKY

COUNTY _____

PROJECT NO. _____

I, _____, _____, under
(Name of officer signing certification) (Title)

penalty of perjury under the laws of the United States, do hereby certify that

(Insert name of Individual, Joint Venture, Co-partnership, or Corporation submitting bid)

its agent, officers or employees have not directly or indirectly entered into any agreement, participated in any collusion, or otherwise taken action in restraint of free competitive bidding in connection with this proposal.

(Signature)

(Title)

REVISED: 8-23-89

NON-COLLUSION CERTIFICATION

COMMONWEALTH OF KENTUCKY

COUNTY _____

PROJECT NO. _____

I, _____, _____, under
(Name of officer signing certification) (Title)

penalty of perjury under the laws of the United States, do hereby certify that

(Insert name of Individual, Joint Venture, Co-partnership, or Corporation submitting bid)

its agent, officers or employees have not directly or indirectly entered into any agreement, participated in any collusion, or otherwise taken action in restraint of free competitive bidding in connection with this proposal.

(Signature)

(Title)

REVISED: 8-23-89

CERTIFICATION OF ORGANIZATION(S)

COMMONWEALTH OF KENTUCKY

COUNTY _____

PROJECT NO. _____

I, _____, _____, under penalty
(President or Authorized Official of Bidder) (Title)

perjury under the laws of the United States, do hereby certify that, except as noted below,

(Insert name of individual, Joint Venture, Co-Partnership or Corporation Submitting Bid)

any person associated therewith in the capacity of (owner, partner, director, officer, principal investigator, project director, manager, auditor, or any position involving the Administration of Federal Funds): is not currently under suspension, debarment, voluntary exclusion, or determination of ineligibility by any federal agency; has not been suspended, debarred, voluntarily excluded or determined ineligible by any federal agency within the past 3 years; does not have a proposed debarment pending; and has not been indicted, convicted, or had a civil judgement rendered against (it) by a court of competent jurisdiction in any matter involving fraud or official misconduct within the past 3 years.

Please list below any exceptions to the foregoing, to whom it applies, initiating agency and dates of action.

Exceptions: _____

(Signature)

(Title)

CERTIFICATION OF PERFORMANCE

Certification with regard to the Performance of Previous Contracts or Subcontracts subject to the Equal Opportunity Clause and the filing of Required Reports.

The bidder _____, proposed subcontractor _____, hereby certifies that he has _____, has not _____, participated in a previous contract or subcontract subject to the equal opportunity clause, as required by Executive Orders 10925, 11114, or 11246, and that he has _____, has not _____, filed with the Joint Reporting Committee, the Director of the Office of Federal Contract Compliance, a Federal Government contracting or administering agency, or the Former President's Committee on Equal Employment Opportunity, all reports due under the applicable filing requirements.

(Company)

By: _____

(Title)

Date: _____

NOTE: The above certification is required by the Equal Employment Opportunity Regulations of the Secretary of Labor (41 CFR 60-1.7(b) (1)), and must be submitted by bidders and proposed subcontractors only in connection with the contracts and subcontracts which are subject to the equal opportunity clause. Contracts and subcontracts which are exempt from the equal opportunity clause are set forth in 41 CFR 60-1.5. (Generally only contracts or subcontracts of \$10,000 or under are exempt.)

Currently, Standard Form 100 (EEO-1) is the only report required by the Executive Orders of their implementing regulation.

Proposed prime contractors and subcontractors who have participated in a previous contract or subcontract subject to the Executive Orders and have not filed reports should note that 41 CFR 60-1.7(b) (1) prevents the award of contracts and subcontracts unless such contractor submits a report covering the delinquent period or such other period specified by the Federal Highway Administration or by the Director, Office of Federal Contract Compliance, U.S. Department of Labor.

CERTIFICATION FOR FEDERAL-AID CONTRACT

The prospective participant certifies, by signing and submitting this bid or proposal, to the best of his or her knowledge and belief, that:

1. No Federal appropriated funds have been paid or will be paid, by or on behalf of the undersigned, to any person for influencing or attempting to influence an officer or employee of any Federal agency, a Member of Congress, an officer or employee of Congress, or an employee of a Member of Congress in connection with the awarding of any Federal contract, the making of any Federal grant, the making of any Federal loan, the entering into of any cooperative agreement, and the extension, continuation, renewal, amendment, or modification of any Federal contract, grant, loan, or cooperative agent.
2. If any funds other than Federal appropriated funds have been paid or will be paid to any person for influencing or attempting to influence an officer or employee of any Federal agency, a Member of Congress, an officer or employee of Congress, or an employee of a Member of Congress in connection with this Federal contract, grant, loan, or cooperative agreement, the undersigned shall complete and submit Standard Form-LLL, "Disclosure Form to Report Lobbying," in accordance with its instructions.

This certification is a material representation of fact which reliance was placed when this transaction was made or entered into. Submission of this certification is a prerequisite for making or entering into this transaction imposed by Section 1352, Title 31, U.S. Code. Any person who fails to file the required certification shall be subject to a civil penalty of not less than \$10,000 and not more than \$100,000 for each such failure.

The prospective participant also agrees by submitting his or her bid or proposal that he or she shall require that the language of this certification be included in all lower tier subcontracts, which exceed \$100,000 and that all such subrecipients shall certify and disclose accordingly.

(Insert name of Individual, Joint Venture, Co-partnership, or Corporation submitting bid)

(Signature)

(Title)

CERTIFICATION OF BID PROPOSAL / DBE

We (I) propose to furnish all labor, equipment and materials necessary to construct and/or improve the subject project in accordance with the plans, the Transportation Cabinet's Standard Specifications for Road and Bridge Construction, current edition, special provisions, notes applicable to the project as indicated herein and all addenda issued on this project subsequent to purchase of proposal.

We (I) attach a bid proposal guaranty as provided in the special provisions in an amount not less than 5% of the total bid. We agree to execute a contract in accordance with this bid proposal within 15 calendar days after the receipt of the notice of award for the project.

We (I) have examined the site of proposed work, project plans, specifications, special provisions, and notes applicable to the project referred to herein. We understand that the quantities shown herein are estimated quantities subject to increase or decrease as provided in the specifications.

We (I) acknowledge receipt of all addendum(s) (if applicable) and have made the necessary revisions to the bid proposal. We have considered all addendum(s) in the calculation of the submitted bid and applied the updated bid items, which are included.

“The bidder certifies that it has secured participation by Disadvantaged Business Enterprises (“DBE”) in the amount of _____ percent of the total value of this contract and that the DBE participation is in compliance with the requirements of 49 CFR 26 and the policies of the Kentucky Transportation Cabinet pertaining to the DBE Program.”

Name of Contracting Firm

BY: _____
Authorized Agent (Signature) Title

Address City State Zip Code

Telephone Number

When two or more organizations bid as a joint venture, enter names of each organization and an authorized agent for each organization must sign above.