



CALL NO. 100

CONTRACT ID. 221352

LAUREL COUNTY

FED/STATE PROJECT NUMBER NHPP 0251 (037)

DESCRIPTION CUMBERLAND GAP PARKWAY (US25E)

WORK TYPE GRADE & DRAIN AND PAVEMENT ALTERNATES

PRIMARY COMPLETION DATE 7/1/2024

LETTING DATE: October 20,2022

Sealed Bids will be received electronically through the Bid Express bidding service until 10:00 AM EASTERN DAYLIGHT TIME October 20,2022. Bids will be publicly announced at 10:00 AM EASTERN DAYLIGHT TIME.

PLANS AVAILABLE FOR THIS PROJECT.

DBE CERTIFICATION REQUIRED - 11%

REQUIRED BID PROPOSAL GUARANTY: Not less than 5% of the total bid.

TABLE OF CONTENTS

PART I	SCOPE OF WORK <ul style="list-style-type: none">• PROJECT(S), COMPLETION DATE(S), & LIQUIDATED DAMAGES• CONTRACT NOTES• FEDERAL CONTRACT NOTES• NATIONAL HIGHWAY• ASPHALT MIXTURE• INCIDENTAL SURFACING• JPC RIDE QUALITY• ASPHALT PAVEMENT RIDE QUALITY CAT B• FUEL AND ASPHALT PAY ADJUSTMENT• COMPACTION OPTION A• SPECIAL NOTE(S) APPLICABLE TO PROJECT• TREE REMOVAL• PIPELINE INSPECTION• EXPERIMENTAL KYCT AND HAMBURG TESTING• BRIDGE DEMOLITION, RENOVATION AND ASBESTOS ABATEMENT• ASBESTOS ABATEMENT REPORT• RIGHT OF WAY CERTIFICATION• UTILITY IMPACT & RAIL CERTIFICATION NOTES• GENERAL UTILITY NOTES• WATER STANDARD UTILITY BID ITEMS• WATERLINE SPECIFICATIONS• SEWER STANDARD UTILITY BID ITEMS• KPDES STORM WATER PERMIT, BMP AND APPROVAL LETTER
PART II	SPECIFICATIONS AND STANDARD DRAWINGS <ul style="list-style-type: none">• SPECIFICATIONS REFERENCE• SUPPLEMENTAL SPECIFICATION• [SN-11] PORTABLE CHANGEABLE SIGNS• [SP-69] EMBANKMENT AT BRIDGE END BENT STRUCTURES• RAIL SYSTEM TYPE 3• INLAID PAVEMENT MARKER ARRANGEMENTS MULTI-LANE ROADWAYS• INLAID PAVEMENT MARKER ARRANGEMENTS MULTI-LANE ROADWAYS• INLAID PAVEMENT MARKER ARRANGEMENTS TWO-WAY, LEFT-TURN LANE• INLAID PAVEMENT MARKER ARRANGEMENT CHANNELIZED INTERSECTION• PAVEMENT STRIPING DETAILS FOR TWO LANE TWO WAY ROADWAYS
PART III	EMPLOYMENT, WAGE AND RECORD REQUIREMENTS <ul style="list-style-type: none">• FEDERAL-AID CONSTRUCTION CONTRACTS - FHWA 1273• NONDISCRIMINATION OF EMPLOYEES• EXECUTIVE BRANCH CODE OF ETHICS• PROJECT WAGE RATES LOCALITY 2 / FEDERAL• NOTICE OF REQUIREMENT FOR AFFIRMATIVE ACTION TO ENSURE EEO LAUREL
PART IV	INSURANCE

PART V BID ITEMS

PART I
SCOPE OF WORK

ADMINISTRATIVE DISTRICT - 11

CONTRACT ID - 221352

NHPP 0251 (037)

COUNTY - LAUREL

PCN - DE063025E2233

NHPP 0251 (037)

CUMBERLAND GAP PARKWAY (US25E) REDUCE CONGESTION ON US25E FROM KNOX COUNTY LINE TO KY 770, A DISTANCE OF 01.85 MILES.GRADE & DRAIN AND PAVEMENT ALTERNATES SYP NO. 11-00185.00.

GEOGRAPHIC COORDINATES LATITUDE 36:58:26.00 LONGITUDE 84:05:59.00

ADT 23,463

COMPLETION DATE(S):

COMPLETED BY 07/01/2024

CONTRACT TIME

CONTRACT NOTES

PROPOSAL ADDENDA

All addenda to this proposal must be applied when calculating bid and certified in the bid packet submitted to the Kentucky Department of Highways. Failure to use the correct and most recent addenda may result in the bid being rejected.

BID SUBMITTAL

Bidder must use the Department's electronic bidding software. The Bidder must download the bid file located on the Bid Express website (www.bidx.com) to prepare a bid packet for submission to the Department. The bidder must submit electronically using Bid Express.

JOINT VENTURE BIDDING

Joint venture bidding is permissible. All companies in the joint venture must be prequalified in one of the work types in the Qualifications for Bidders for the project. The bidders must get a vendor ID for the joint venture from the Division of Construction Procurement and register the joint venture as a bidder on the project. Also, the joint venture must obtain a digital ID from Bid Express to submit a bid. A joint bid bond of 5% may be submitted for both companies or each company may submit a separate bond of 5%.

UNDERGROUND FACILITY DAMAGE PROTECTION

The contractor shall make every effort to protect underground facilities from damage as prescribed in the Underground Facility Damage Protection Act of 1994, Kentucky Revised Statute KRS 367.4901 to 367.4917. It is the contractor's responsibility to determine and take steps necessary to be in compliance with federal and state damage prevention directives. When prescribed in said directives, the contractor shall submit Excavation Locate Requests to the Kentucky Contact Center (KY811) via web ticket entry. The submission of this request does not relieve the contractor from the responsibility of contacting non-member facility owners, whom shall be contacted through their individual Protection Notification Center. Non-compliance with these directives can result in the enforcement of penalties.

REGISTRATION WITH THE SECRETARY OF STATE BY A FOREIGN ENTITY

Pursuant to KRS 176.085(1)(b), an agency, department, office, or political subdivision of the Commonwealth of Kentucky shall not award a state contract to a person that is a foreign entity required by [KRS 14A.9-010](#) to obtain a certificate of authority to transact business in the Commonwealth ("certificate") from the Secretary of State under [KRS 14A.9-030](#) unless the person produces the certificate within fourteen (14) days of the bid or proposal opening. If the foreign entity is not required to obtain a certificate as provided in [KRS 14A.9-010](#), the foreign entity should identify the applicable exception. Foreign entity is defined within [KRS 14A.1-070](#).

For all foreign entities required to obtain a certificate of authority to transact business in the Commonwealth, if a copy of the certificate is not received by the contracting agency within the time frame identified above, the foreign entity's solicitation response shall be deemed non-responsive or the awarded contract shall be cancelled.

Businesses can register with the Secretary of State at <https://secure.kentucky.gov/sos/ftbr/welcome.aspx>.

SPECIAL NOTE FOR PROJECT QUESTIONS DURING ADVERTISEMENT

Questions about projects during the advertisement should be submitted in writing to the Division of Construction Procurement. This may be done by fax (502) 564-7299 or email to kytc.projectquestions@ky.gov. The Department will attempt to answer all submitted questions. The Department reserves the right not to answer if the question is not pertinent or does not aid in clarifying the project intent.

The deadline for posting answers will be 3:00 pm Eastern Daylight Time, the day preceding the Letting. Questions may be submitted until this deadline with the understanding that the later a question is submitted, the less likely an answer will be able to be provided.

The questions and answers will be posted for each Letting under the heading "Questions & Answers" on the Construction Procurement website (www.transportation.ky.gov/contract). The answers provided shall be considered part of this Special Note and, in case of a discrepancy, will govern over all other bidding documents.

HARDWOOD REMOVAL RESTRICTIONS

The US Department of Agriculture has imposed a quarantine in Kentucky and several surrounding states, to prevent the spread of an invasive insect, the emerald ash borer. Hardwood cut in conjunction with the project may not be removed from the state. Chipping or burning on site is the preferred method of disposal.

INSTRUCTIONS FOR EXCESS MATERIAL SITES AND BORROW SITES

Identification of excess material sites and borrow sites shall be the responsibility of the Contractor. The Contractor shall be responsible for compliance with all applicable state and federal laws and may wish to consult with the US Fish and Wildlife Service to seek protection under Section 10 of the Endangered Species Act for these activities.

ACCESS TO RECORDS

The contractor, as defined in KRS 45A.030 (9) agrees that the contracting agency, the Finance and Administration Cabinet, the Auditor of Public Accounts, and the Legislative Research Commission, or their duly authorized representatives, shall have access to any books, documents, papers, records, or other evidence, which are directly pertinent to this contract for the purpose of financial audit or program review. Records and other prequalification information confidentially

disclosed as part of the bid process shall not be deemed as directly pertinent to the contract and shall be exempt from disclosure as provided in KRS 61.878(1)(c). The contractor also recognizes that any books, documents, papers, records, or other evidence, received during a financial audit or program review shall be subject to the Kentucky Open Records Act, KRS 61.870 to 61.884.

In the event of a dispute between the contractor and the contracting agency, Attorney General, or the Auditor of Public Accounts over documents that are eligible for production and review, the Finance and Administration Cabinet shall review the dispute and issue a determination, in accordance with Secretary's Order 11-004.

April 30, 2018

FEDERAL CONTRACT NOTES

The Kentucky Department of Highways, in accordance with the Regulations of the United States Department of Transportation 23 CFR 635.112 (h), hereby notifies all bidders that failure by a bidder to comply with all applicable sections of the current Kentucky Standard Specifications, including, but not limited to the following, may result in a bid not being considered responsive and thus not eligible to be considered for award:

- | | |
|--------------------------------|--|
| 102.02 Current Rating | 102.08 Preparation and Delivery of Proposals |
| 102.13 Irregular Bid Proposals | 102.14 Disqualification of Bidders |
| 102.09 Proposal Guaranty | |

CIVIL RIGHTS ACT OF 1964

The Kentucky Transportation Cabinet, Department of Highways, in accordance with the provisions of Title VI of the Civil Rights Act of 1964 (78 Stat. 252, 42 U.S.C. §§ 2000d to 2000d-4) and the Regulations, hereby notifies all bidders that it will affirmatively ensure that any contract entered into pursuant to this advertisement, disadvantaged business enterprises will be afforded full and fair opportunity to submit bids in response to this invitation and will not be discriminated against on the grounds of race, color, national origin, sex, age (over 40), religion, sexual orientation, gender identity, veteran status, disability, income-level, or Limited English Proficiency (LEP) in consideration for an award.

NOTICE TO ALL BIDDERS

To report bid rigging activities call: 1-800-424-9071.

The U.S. Department of Transportation (DOT) operates the above toll-free “hotline” Monday through Friday, 8:00 a.m. to 5:00 p.m. eastern time. Anyone with knowledge of possible bid rigging, bidder collusion, or other fraudulent activities should use the “hotline” to report such activities.

The “hotline” is part of the DOT’s continuing effort to identify and investigate highway construction contract fraud and abuse and is operated under the direction of the DOT Inspector General. All information will be treated confidentially and caller anonymity will be respected.

SECOND TIER SUBCONTRACTS

Second tier subcontracts are acceptable per Section 108.01 of the Standard Specifications for Road and Bridge Construction. Sub-Contractors fulfilling a disadvantaged business enterprise goal on a project may enter into a 2nd tier subcontract with a Non-DBE Subcontractor. However, in this instance, none of the work subcontracted to the Non-DBE Contractor will count toward fulfilling the established Disadvantaged Goal for the project.

DISADVANTAGED BUSINESS ENTERPRISE PROGRAM

It is the policy of the Kentucky Transportation Cabinet (“the Cabinet”) that Disadvantaged Business Enterprises (“DBE”) shall have the opportunity to participate in the performance of highway construction projects financed in whole or in part by Federal Funds in order to create a level playing field for all businesses who wish to contract with the Cabinet. To that end, the Cabinet will comply with the regulations found in 49 CFR Part 26, and the definitions and requirements contained therein shall be adopted as if set out verbatim herein.

The Cabinet, contractors, subcontractors, and sub-recipients shall not discriminate on the basis of race, color, national origin, or sex in the performance of work performed pursuant to Cabinet contracts. The contractor shall carry out applicable requirements of 49 CFR 26 in the award and administration of federally assisted highway construction projects. The contractor will include this provision in all its subcontracts and supply agreements pertaining to contracts with the Cabinet.

Failure by the contractor to carry out these requirements is a material breach of its contract with the Cabinet, which may result in the termination of the contract or such other remedy as the Cabinet deems necessary.

DBE GOAL

The Disadvantaged Business Enterprise (DBE) goal established for this contract, as listed on the front page of the proposal, is the percentage of the total value of the contract.

The contractor shall exercise all necessary and reasonable steps to ensure that Disadvantaged Business Enterprises participate in a least the percent of the contract as set forth above as goals for this contract.

OBLIGATION OF CONTRACTORS

Each contractor prequalified to perform work on Cabinet projects shall designate and make known to the Cabinet a liaison officer who is assigned the responsibility of effectively administering and promoting an active program for utilization of DBEs.

If a formal goal has not been designated for the contract, all contractors are encouraged to consider DBEs for subcontract work as well as for the supply of material and services needed to perform this work.

Contractors are encouraged to use the services of banks owned and controlled by minorities and women.

CERTIFICATION OF CONTRACT GOAL

Contractors shall include the following certification in bids for projects for which a DBE goal has been established. BIDS SUBMITTED WHICH DO NOT INCLUDE CERTIFICATION OF DBE PARTICIPATION WILL NOT BE ACCEPTED. These bids will not be considered for award by the Cabinet and they will be returned to the bidder.

“The bidder certifies that it has secured participation by Disadvantaged Business Enterprises (“DBE”) in the amount of _____ percent of the total value of this contract and that the DBE participation is in compliance with the requirements of 49 CFR 26 and the policies of the Kentucky Transportation Cabinet pertaining to the DBE Program.”

The certification statement is located in the electronic bid file. All contractors must certify their DBE participation on that page. DBEs utilized in achieving the DBE goal must be certified and prequalified for the work items at the time the bid is submitted.

DBE PARTICIPATION PLAN

Lowest responsive bidders must submit the *DBE Plan/ Subcontractor Request*, form TC 14-35 DBE, within **5** days of the letting. This is necessary before the Awards Committee will review and make a recommendation. **The project will not be considered for award prior to submission and approval of the apparent low bidder’s DBE Plan/Subcontractor Request.**

The DBE Participation Plan shall include the following:

1. Name and address of DBE Subcontractor(s) and/or supplier(s) intended to be used in the proposed project;
2. Description of the work each is to perform including the work item, unit, quantity, unit price and total amount of the work to be performed by the individual DBE. The Proposal Line Number, Category Number, and the Project Line Number can be found in the “material listing” on the Construction Procurement website under the specific letting;
3. The dollar value of each proposed DBE subcontract and the percentage of total project contract value this represents. DBE participation may be counted as follows:
 - a. If DBE suppliers and manufactures assume actual and contractual responsibility, the dollar value of materials to be furnished will be counted toward the goal as follows:
 - The entire expenditure paid to a DBE manufacturer;
 - 60 percent of expenditures to DBE suppliers that are not manufacturers provided the supplier is a regular dealer in the product involved. A regular dealer must be engaged in, as its principal business and in its own name, the sale of products to the public, maintain an inventory and own and operate distribution equipment; and
 - The amount of fees or commissions charged by the DBE firms for a bona fide service, such as professional, technical, consultant, or managerial services and assistance in the procurement of essential personnel, facilities, equipment, materials, supplies, delivery of materials and supplies or for furnishing bonds, or insurance, providing such fees or commissions are determined to be reasonable and customary.

- b) The dollar value of services provided by DBEs such as quality control testing, equipment repair and maintenance, engineering, staking, etc.;
- c) The dollar value of joint ventures. DBE credit for joint ventures will be limited to the dollar amount of the work actually performed by the DBE in the joint venture;
4. Written and signed documentation of the bidder's commitment to use a DBE contractor whose participation is being utilized to meet the DBE goal; and
5. Written and signed confirmation from the DBE that it is participating in the contract as provided in the prime contractor's commitment.

UPON AWARD AND BEFORE A WORK ORDER WILL BE ISSUED

Contractors must submit the signed subcontract between the contractor and the DBE contractor, along with the DBE's certificate of insurance. If the DBE is a supplier of materials for the project, a signed purchase order must be submitted to the Division of Construction Procurement.

Changes to DBE Participation Plans must be approved by the Cabinet. The Cabinet may consider extenuating circumstances including, but not limited to, changes in the nature or scope of the project, the inability or unwillingness of a DBE to perform the work in accordance with the bid, and/or other circumstances beyond the control of the prime contractor.

CONSIDERATION OF GOOD FAITH EFFORTS REQUESTS

If the DBE participation submitted in the bid by the apparent lowest responsive bidder does not meet or exceed the DBE contract goal, the apparent lowest responsive bidder must submit a Good Faith Effort Package to satisfy the Cabinet that sufficient good faith efforts were made to meet the contract goals prior to submission of the bid. Efforts to increase the goal after bid submission will not be considered in justifying the good faith effort, unless the contractor can show that the proposed DBE was solicited prior to the letting date. DBEs utilized in achieving the DBE goal must be certified and prequalified for the work items at the time the bid is submitted. One complete set (hard copy along with an electronic copy) of this information must be received in the Division of Contract Procurement no later than 12:00 noon of the tenth calendar day after receipt of notification that they are the apparent low bidder.

Where the information submitted includes repetitious solicitation letters it will be acceptable to submit a sample representative letter along with a distribution list of the firms solicited. Documentation of DBE quotations shall be a part of the good faith effort submittal as necessary to demonstrate compliance with the factors listed below which the Cabinet considers in judging good faith efforts. This documentation may include written subcontractors' quotations, telephone log notations of verbal quotations, or other types of quotation documentation.

The Good Faith Effort Package shall include, but may not be limited to information showing evidence of the following:

1. Whether the bidder attended any pre-bid meetings that were scheduled by the Cabinet to inform DBEs of subcontracting opportunities;
2. Whether the bidder provided solicitations through all reasonable and available means;
3. Whether the bidder provided written notice to all DBEs listed in the DBE directory at the time of the letting who are prequalified in the areas of work that the bidder will be subcontracting;
4. Whether the bidder followed up initial solicitations of interest by contacting DBEs to determine with certainty whether they were interested. If a reasonable amount of DBEs within the targeted districts do not provide an intent to quote or no DBEs are prequalified in the subcontracted areas, the bidder must notify the Disadvantaged Enterprise Business Liaison Officer (DEBLO) in the Office for Civil Rights and Small Business Development to give notification of the bidder's inability to get DBE quotes;
5. Whether the bidder selected portions of the work to be performed by DBEs in order to increase the likelihood of meeting the contract goals. This includes, where appropriate, breaking out contract work items into economically feasible units to facilitate DBE participation, even when the prime contractor might otherwise perform these work items with its own forces;
6. Whether the bidder provided interested DBEs with adequate and timely information about the plans, specifications, and requirements of the contract;
7. Whether the bidder negotiated in good faith with interested DBEs not rejecting them as unqualified without sound reasons based on a thorough investigation of their capabilities. Any rejection should be so noted in writing with a description as to why an agreement could not be reached;
8. Whether quotations were received from interested DBE firms but were rejected as unacceptable without sound reasons why the quotations were considered unacceptable. The fact that the DBE firm's quotation for the work is not the lowest quotation received will not in itself be considered as a sound reason for rejecting the quotation as unacceptable. The fact that the bidder has the ability and/or desire to perform the contract work with its own forces will not be considered a sound reason for rejecting a DBE quote. Nothing in this provision shall be construed to require the bidder to accept unreasonable quotes in order to satisfy DBE goals;
9. Whether the bidder specifically negotiated with subcontractors to assume part of the responsibility to meet the contract DBE goal when the work to be subcontracted includes potential DBE participation;
10. Whether the bidder made any efforts and/or offered assistance to interested DBEs in obtaining the necessary equipment, supplies, materials, insurance and/or bonding to satisfy the work requirements of the bid proposal; and
11. Any other evidence that the bidder submits which may show that the bidder has made reasonable good faith efforts to include DBE participation.

FAILURE TO MEET GOOD FAITH REQUIREMENT

Where the apparent lowest responsive bidder fails to submit sufficient participation by DBE firms to meet the contract goal and upon a determination by the Good Faith Committee based upon the information submitted that the apparent lowest responsive bidder failed to make sufficient reasonable efforts to meet the contract goal, the bidder will be offered the opportunity to meet in person for administrative reconsideration. The bidder will be notified of the Committee's decision within 24 hours of its decision. The bidder will have 24 hours to request reconsideration of the Committee's decision. The reconsideration meeting will be held within two days of the receipt of a request by the bidder for reconsideration.

The request for reconsideration will be heard by the Office of the Secretary. The bidder will have the opportunity to present written documentation or argument concerning the issue of whether it met the goal or made an adequate good faith effort. The bidder will receive a written decision on the reconsideration explaining the basis for the finding that the bidder did or did not meet the goal or made adequate Good Faith efforts to do so.

The result of the reconsideration process is not administratively appealable to the Cabinet or to the United States Department of Transportation.

The Cabinet reserves the right to award the contract to the next lowest responsive bidder or to rebid the contract in the event that the contract is not awarded to the low bidder as the result of a failure to meet the good faith requirement.

SANCTIONS FOR FAILURE TO MEET DBE REQUIREMENTS OF THE PROJECT

Failure by the prime contractor to fulfill the DBE requirements of a project under contract or to demonstrate good faith efforts to meet the goal constitutes a breach of contract. When this occurs, the Cabinet will hold the prime contractor accountable, as would be the case with all other contract provisions. Therefore, the contractor's failure to carry out the DBE contract requirements shall constitute a breach of contract and as such the Cabinet reserves the right to exercise all administrative remedies at its disposal including, but not limited to the following:

- Suspension of Prequalification;
- Disallow credit toward the DBE goal;
- Withholding progress payments;
- Withholding payment to the prime in an amount equal to the unmet portion of the contract goal; and/or
- Termination of the contract.

PROMPT PAYMENT

The prime contractor will be required to pay the DBE and Non-DBE Subcontractors within seven (7) working days after he or she has received payment from the Kentucky Transportation Cabinet for work performed or materials furnished.

CONTRACTOR REPORTING

All contractors must keep detailed records and provide reports to the Cabinet on their progress in meeting the DBE requirement on any highway contract. These records may include, but shall not be limited to payroll, lease agreements, cancelled payroll checks, executed subcontracting agreements, etc. Prime contractors will be required to complete and submit a **signed and notarized** Affidavit of Subcontractor Payment (TC 18-7) and copies of checks for any monies paid to each DBE subcontractor or supplier utilized to meet a DBE goal. These documents must be completed and signed within 7 days of being paid by the Cabinet.

Payment information that needs to be reported includes date the payment is sent to the DBE, check number, Contract ID, amount of payment and the check date. Before Final Payment is made on this contract, the Prime Contractor will certify that all payments were made to the DBE subcontractor and/or DBE suppliers.

***** IMPORTANT *****

Please mail the original, signed and completed TC (18-7) Affidavit of Subcontractor Payment form and all copies of checks for payments listed above to the following address:

Office for Civil Rights and Small Business Development
6th Floor West 200 Mero Street
Frankfort, KY 40622

The prime contractor should notify the KYTC Office for Civil Rights and Small Business Development seven (7) days prior to DBE contractors commencing work on the project. The contact in this office is Mr. Melvin Bynes. Mr. Bynes' current contact information is email address – melvin.bynes2@ky.gov and the telephone number is (502) 564-3601.

DEFAULT OR DECERTIFICATION OF THE DBE

If the DBE subcontractor or supplier is decertified or defaults in the performance of its work, and the overall goal cannot be credited for the uncompleted work, the prime contractor may utilize a substitute DBE or elect to fulfill the DBE goal with another DBE on a different work item. If after exerting good faith effort in accordance with the Cabinet's Good Faith Effort policies and procedures, the prime contractor is unable to replace the DBE, then the unmet portion of the goal may be waived at the discretion of the Cabinet.

PROHIBITION ON TELECOMMUNICATIONS EQUIPMENT OR SERVICES

In accordance with the FY 2019 National Defense Authorization Act (NDAA), 2 CFR 200.216, and 2 CFR 200.471, Federal agencies are prohibited, after August 13, 2020, from obligating or expending financial assistance to obtain certain telecommunications and video surveillance services and equipment from specific producers. As a result of these regulations, contractors and subcontractors are prohibited, on projects with federal funding participation, from providing telecommunication or video surveillance equipment, services, or systems produced by:

- Huawei Technologies Company or ZTE Corporation (or any subsidiary or affiliate of such entities)
- Hytera Communications Corporation, Hangzhou Hikvision Digital Technology Company, or Dahua Technology Company (or any subsidiary or affiliate of such entities)

LEGAL REQUIREMENTS AND RESPONSIBILITY TO THE PUBLIC – CARGO PREFERENCE ACT (CPA).

(REV 12-17-15) (1-16)

SECTION 7 is expanded by the following new Article:

102.10 **Cargo Preference Act – Use of United States-flag vessels.**

Pursuant to Title 46CFR Part 381, the Contractor agrees

- To utilize privately owned United States-flag commercial vessels to ship at least 50 percent of the gross tonnage (computed separately for dry bulk carriers, dry cargo liners, and tankers) involved, whenever shipping any equipment, material, or commodities pursuant to this contract, to the extent such vessels are available at fair and reasonable rates for United States-flag commercial vessels.
- To furnish within 20 days following the date of loading for shipments originating within the United States or within 30 working days following the date of loading for shipments originating outside the United States, a legible copy of a rated, ‘on-board’ commercial ocean bill-of-lading in English for each shipment of cargo described in paragraph 1 of this section to both the Contracting Officer (through the prime contractor in the case of subcontractor bills-of-lading) and to the Division of National Cargo, Office of Market Development, Maritime Administration, Washington, DC 20590.
- To insert the substance of the provisions of this clause in all subcontracts issued pursuant to this contract.

NATIONAL HIGHWAY

Be advised this project is on the NATIONAL HIGHWAY SYSTEM.

ASPHALT MIXTURE

Unless otherwise noted, the Department estimates the rate of application for all asphalt mixtures to be 110 lbs/sy per inch of depth.

INCIDENTAL SURFACING

The Department has included in the quantities of asphalt mixtures established in the proposal estimated quantities required for resurfacing or surfacing mailbox turnouts, farm field entrances, residential and commercial entrances, curve widening, ramp gores and tapers, and road and street approaches, as applicable. Pave these areas to the limits as shown on Standard Drawing RPM-110-06 or as directed by the Engineer. In the event signal detectors are present in the intersecting streets or roads, pave the crossroads to the right of way limit or back of the signal detector, whichever is the farthest back of the mainline. Surface or resurface these areas as directed by the Engineer. The Department will not measure placing and compacting for separate payment but shall be incidental to the Contract unit price for the asphalt mixtures.

JPC RIDE QUALITY

The Department will apply JPC Ride Quality requirements on this project in accordance with Section 501.03.19(B).

ASPHALT PAVEMENT RIDE QUALITY CATEGORY B

The Department will apply Pavement Rideability Requirements on this project in accordance with Section 410, Category B.

FUEL AND ASPHALT PAY ADJUSTMENT

The Department has included the Contract items Asphalt Adjustment and Fuel Adjustment for possible future payments at an established Contract unit price of \$1.00. The Department will calculate actual adjustment quantities after work is completed. If existing Contract amount is insufficient to pay all items on the contract with the adjustments, the Department will establish additional monies with a change order.

OPTION A

Be advised that the Department will accept compaction of asphalt mixtures furnished for driving lanes and ramps, at 1 inch (25mm) or greater, on this project according to OPTION A in accordance with Section 402 and Section 403 of the current Standard Specifications. The Department will require joint cores as described in Section 402.03.02 for surface mixtures only. The Department will accept compaction of all other asphalt mixtures according to OPTION B.

Laurel County
Item Number: 11-0185.00

SPECIAL NOTE
ALTERNATE PAVEMENT BID ADJUSTMENT

This project includes alternate bidding for asphalt or concrete pavement. There are specific items listed for each pavement type to be bid with the alternate selected by the Contractor. There is also a line item in the alternate categories for each alternate to adjust for the projected out-year life-cycle costs to the Cabinet. These line item adjustments are as follows:

Asphalt Pavement Adjustment = **\$401,420**

Concrete Pavement Adjustment = **\$203,944**

The amount reflective of the pavement type selected by each contractor will be added to their respective bid for comparison of the low bid. The adjustment *shall be used only for determination of the lowest bidder and shall not be used to determine the final payment* to the contractor when the project is completed.

Please note that these adjustments should not be used for the calculation of the maximum Mobilization amount and are not required to be included in the minimum Demobilization amount.

Proposal Guaranty

As a supplement to Section 102 of the Standard Specifications, it will not be necessary for the Proposal Guaranty to include an amount necessary to cover the amount of the bid adjustment.

SPECIAL NOTE FOR GATE INSTALLATION

A portion of fencing and the gate for Parcel 27 will be required to be removed for roadway construction. The contractor will be required to coordinate the removal of the fence and gate with both parcel owners of Parcel 27 and Parcel 34.

Construction

The owner of Parcel 27 will be installing a new gate while the highway construction is in progress. Coordinate efforts of the highway construction with the gate installation. Additionally, the owner of Parcel 27 will provide a detail for the gate installation to the contractor and the contractor will be required to place Class A concrete to the dimensions and specifications required by the gate manufacturer and the instructions of the gate manufacturer and owner of Parcel 27. Excavate, form and place Class A Concrete in accordance with the standard specifications. If required, cast any posts, hardware, or reinforcing steel in the concrete in accordance with the provided details and instructions.

Measurement

The quantity of Class A Concrete will be field measured to the neat lines of the proposed installation. The engineer will measure and contractor agree on the measured quantity for final payment.

Payment

The field measured quantity of "Concrete-Class A" will be considered full compensation for all labor, equipment and materials necessary to complete the placement of the concrete required for the gate installation. The property owner will be responsible to furnish any posts, conduit, hardware or any other materials necessary to complete the installation. The contractor will be responsible to lay out the installation, perform any pavement removal, excavate, form, install conduit, hardware, etc, provide and place any required steel reinforcement, place, finish and cure concrete. No additional measurement or payment will be allowed for steel reinforcement or other items that may be necessary to complete the concrete placement for the proposed gate installation.

Removal of existing fence and gates will be considered incidental to "Clearing and Grubbing".

SPECIAL NOTE FOR INSTALL RADAR PRESENCE DETECTOR TYPE A

Install Radar Presence Detector Type A shall consist of installation of a pole-mounted radar presence sensor, sensor mounting bracket, sensor cables, interface boxes, lead-in cable, connectors, detection cards, and controller interface assembly. Installation of multiple detector cards that use the same radar sensor (such as mainline through movements and adjacent left-turn movement) shall pay as a single installation.

Radar Presence Detector Type A bid item shall include all labor required to provide a functional detection system. Radar Presence Detector Type A shall be installed and wired in accordance with the manufacturer's instructions. After the detector is installed and before the detector is powered on, the contractor shall coordinate with District Traffic Engineering representatives to schedule a time to perform the detector setup. The contractor shall double check to verify that all wiring is correctly installed and connected before scheduling the setup work. Representatives from KYTC and/or the manufacturer or sales representative will assist with setup and calibration. The contractor shall provide a bucket truck and operators at this time for final aiming of the sensors. The contractor shall provide individuals capable of operating the setup software and learning the setup process so that future installations may be completed without assistance from others.

For any installation using existing poles, this item also includes the removal of all existing loop lead-in cable from cabinet, poles, and spans. All existing loops, loop conduits, and loop junction boxes may be abandoned in the ground.

SPECIAL NOTE

EXCESS MATERIAL SITES

Laurel County US-25E Widening Item No. 11-0185

The construction activities of this project may result in a considerable amount of excess material and/or need for borrow areas. It is the contractor's responsibility to dispose of any material in compliance with the United States Army Corps of Engineers (USACE) and Kentucky Division of Water (DOW) rules and regulations pertaining to discharges into Waters of the U.S. The contractor is also responsible to ensure material disposal actions are in compliance with the US Fish and Wildlife Service (USFWS) rules and regulations pertaining to the Endangered Species Act, Section 106 of the National Historic Preservation Act, Floodplains, as well as any other pertinent regulations.

The Kentucky Transportation Cabinet (KYTC) has acquired Section 404 (USACE) & 401 (DOW) permits for the construction disturbances shown in the plans pertaining to this project. It is the contractor's responsibility to review the Clean Water Act 404 & 401 permits and maintain compliance with the 401 & 404 permits throughout the duration of the project.

Mitigation requirements resulting from the construction disturbances shown in the plans pertaining to this project will be in the form of in-lieu fees and will be paid by the KYTC prior to stream/wetland impacts occurring from construction activities.

However, the Kentucky Transportation Cabinet (KYTC) has not identified any excess material sites or borrow areas, or acquired property/easements or Section 404 (USACE) & 401 (DOW) permits for any excess material sites or borrow areas on this project. It will be the responsibility of the contractor to:

- Identify excess material sites and/or borrow areas.
 - A list of potential sites shall be presented at the Pre-Construction Meeting.
 - Sites that minimize environmental impacts will be preferred.
 - Sites that impact Outstanding State Resource Waters (<http://eppcapp.ky.gov/spwaters/>, <https://apps.legislature.ky.gov/Law/KAR/401/010/026.pdf>) will not be permitted.
- Secure property rights and access to the excess material sites and/or borrow areas.
- Obtain environmental clearances through a KYTC pre-qualified firm for Section 7, Section 106, and Wetlands. Any cost associated with these studies will be the responsibility of the contractor.
- Obtain Section 404 (USACE) & 401 (DOW) permits for excess material sites and/or borrow areas that they identify and intend to use.

No additional contract time will be allowed for this process.

The Section 404 (USACE) & 401 (DOW) permits obtained by the Kentucky Transportation Cabinet (KYTC) for construction disturbances shown in the plans cannot be modified or amended.

The contractor will be responsible for any environmental fees that are associated with excess material sites and/or borrow areas including but not limited to: USFWS fees for tree cutting, in-lieu fees for stream mitigation, etc.

The contractor is responsible for obtaining, maintaining, and repairing accesses to ALL sites through public or private property.

All work associated with KYTC permitted construction areas and contractor identified excess material sites and/or borrow areas will be incidental to the excavation cost including but not limited to the following items: Environmental Studies and Fees, Access Road Acquisition/Maintenance/Repair, Erosion Control Devices, Clearing and Grubbing, Seeding and Protection, Utility Relocation, Temporary and Permanent Drainage Ditches, and Structures (including pipes, culverts, etc.)

Questions concerning any potential impacts to “Waters of the United States” should be brought to the attention of the appropriate District Office of the Corps of Engineers for determination, prior to disturbance. Any fees associated with obtaining permit approvals for the disposal of excess material and/or use of borrow areas from the USFWS, USACE or other appropriate regulatory agencies are the responsibility of the contractor.

All new permit approvals (401/404, Section 7, Section 106, etc.) must be completed prior to disturbance of excess material site(s).

Any communications made by the contractor with regulatory agencies must copy:

KYTC DEA (andrew.logsdon@ky.gov)

< OR >

Attn: Andrew Logsdon

KYTC Division of Environmental Analysis

200 Mero Street, Frankfort KY 40622

SPECIAL NOTE

Hazardous Materials

Laurel County

Improve safety, improve access management, and reduce congestion on
US-25E from the Knox/Laurel line to KY-770.

Item No. 11-0185

Should suspect petroleum contaminated soils be encountered during excavation/construction they should not be reused or discarded without KYTC authorization. The Contractor shall immediately contact KYTC Division of Environmental Analysis (DEA), (Chris Cummins, Brittany Lowry) at (502) 564-7250. KYTC DEA will coordinate with a UST/Hazmat Statewide Contractor to assist the contractor in characterizing the soil and/or groundwater for removal/disposal of contaminated material. The contractor may coordinate to work in other areas until the material is removed. Parcels that KYTC has identified but is not limited to potential contamination are P8, P9, P22, P26, P27, P31, P39, P205, P211.

If there are any questions regarding this note, please contact Danny Peake, Director, Division of Environmental Analysis, 200 Mero Street, Frankfort, KY 40601; Phone: (502) 564-7250.

SPECIAL NOTE

For Tree Removal

**Laurel County
Improve Safety on US 25E from Knox/Laurel County Line to
KY 770
Item No. 11-185**

NO CLEARING OF TREES 5 INCHES OR GREATER (DIAMETER BREAST
HEIGHT) FROM JUNE 1 THROUGH JULY 31.

**If there are any questions regarding this note, please contact David Waldner,
Director, Division of Environmental Analysis, 200 Mero Street, Frankfort, KY
40601, Phone: (502) 564-7250.**

SPECIAL NOTE FOR PIPELINE INSPECTION

1.0 DESCRIPTION. The Department will perform visual inspections on all pipe on the project. A video inspection will be required on projects having more than 250 linear feet of storm sewer and/or culvert pipe and on routes with an ADT of greater than 1,000 vehicles. Conduct video inspections on all pipe located under the roadway and 50 percent of the remaining pipe not under the roadway. Storm sewer runs and outfall pipes not under the roadway take precedence over rural entrance pipes. Contractors performing this item of work must be prequalified with the Department in the work type J51 (Video Pipe Inspection and Cleaning). Deflection testing shall be completed using a mandrel in accordance with the procedure outlined below or by physical measurement for pipes greater than 36 inches in diameter. Mandrel testing for deflection must be completed prior to the video inspection testing. Unless otherwise noted, Section references herein are to the Department's Standard Specifications for Road and Bridge Construction, current edition.

2.0 VIDEO INSPECTION. Ensure pipe is clear of water, debris or obstructions. Complete the video inspection and any necessary measurement prior to placing the final surface over any pipe. When paving will not be delayed, take measurements 30 days or more after the completion of earthwork to within 1 foot of the finished subgrade. Notify the Engineer a minimum of 24 hours in advance of inspection and notify the Engineer immediately if distresses or locations of improper installation are logged.

2.1 INSPECTION FOR DEFECTS AND DISTRESSES

A) Begin at the outlet end and proceed through to the inlet at a speed less than or equal to 30 ft/minute. Remove blockages that will prohibit a continuous operation.

B) Document locations of all observed defects and distresses including but not limited to: cracking, spalling, slabbing, exposed reinforcing steel, sags, joint offsets, joint separations, deflections, improper joints/connections, blockages, leaks, rips, tears, buckling, deviation from line and grade, damaged coatings/paved inverts, and other anomalies not consistent with a properly installed pipe.

C) During the video inspection provide a continuous 360 degree pan of every pipe joint.

D) Identify and measure all cracks greater than 0.1" and joint separations greater than 0.5".

E) Video Inspections are conducted from junction to junction which defines a pipe run. A junction is defined as a headwall, drop box inlet, curb box inlet, manhole, buried junction, or other structure that disturbs the continuity of the pipe. Multiple pipe inspections may be conducted from a single set up location, but each pipe run must be on a separate video file and all locations are to be referenced from nearest junction relative to that pipe run.

F) Record and submit all data on the TC 64-765 and TC 64-766 forms.

3.0 MANDREL TESTING. Mandrel testing will be used for deflection testing. For use on Corrugated Metal Pipe, High Density Polyethylene Pipe, and Polyvinyl Chloride Pipe, use a mandrel device with an odd number of legs (9 minimum) having a length not less than the outside diameter of the mandrel. The diameter of the mandrel at any point shall not be less than the diameter specified in Section 3.6. Mandrels can be a fixed size or a variable size.

3.1 Use a proving ring or other method recommended by the mandrel manufacturer to verify mandrel diameter prior to inspection. Provide verification documentation for each size mandrel to the Engineer.

3.2 All deflection measurements are to be based off of the AASHTO Nominal Diameters. Refer to the chart in section 3.6.

3.3 Begin by using a mandrel set to the 5.0% deflection limit. Place the mandrel in the inlet end of the pipe and pull through to the outlet end. If resistance is met prior to completing the entire run, record the maximum distance achieved from the inlet side, then remove the mandrel and continue the inspection from the outlet end of the pipe toward the inlet end. Record the maximum distance achieved from the outlet side.

3.4 If no resistance is met at 5.0% then the inspection is complete. If resistance occurred at 5.0% then repeat 3.1 and 3.2 with the mandrel set to the 10.0% deflection limit. If the deflection of entire pipe run cannot be verified with the mandrel then immediately notify the Engineer.

3.5 Care must be taken when using a mandrel in all pipe material types and lining/coating scenarios. Pipe damaged during the mandrel inspection will be video inspected to determine the extent of the damage. If the damaged pipe was video inspected prior to mandrel inspection then a new video inspection is warranted and supersedes the first video inspection. Immediately notify the Engineer of any damages incurred during the mandrel inspection and submit a revised video inspection report.

3.6 AASHTO Nominal Diameters and Maximum Deflection Limits.

Base Pipe Diameter (inches)	AASHTO Nominal Diameter (inches)	Max. Deflection Limit (inches)	
		5.0%	10.0%
15	14.76	14.02	13.28
18	17.72	16.83	15.95
24	23.62	22.44	21.26
30	29.53	28.05	26.58
36	35.43	33.66	31.89
42	41.34	39.27	37.21
48	47.24	44.88	42.52
54	53.15	50.49	47.84
60	59.06	56.11	53.15

4.0 PHYSICAL MEASUREMENT OF PIPE DEFLECTION. Alternate method for deflection testing when there is available access or the pipe is greater than 36 inches in diameter, as per 4.1. Use a contact or non-contact distance instrument. A leveling device is recommended for establishing or verifying vertical and horizontal control.

4.1 Physical measurements may be taken after installation and compared to the AASHTO Nominal Diameter of the pipe as per Section 3.6. When this method is used, determine the smallest interior diameter of the pipe as measured through the center point of the pipe (D2). All measurements are to be taken from the inside crest of the corrugation. Take the D2 measurements at the most deflected portion of the pipe run in question and at intervals no greater than ten (10) feet through the run. Calculate the deflection as follows:

$$\% \text{ Deflection} = [(AASHTO \text{ Nominal Diameter} - D2) / AASHTO \text{ Nominal Diameter}] \times 100\%$$

Note: The Engineer may require that preset monitoring points be established in the culvert prior to backfilling. For these points the pre-installation measured diameter (D1) is measured and recorded. Deflection may then be calculated from the following formula:

$$\% \text{ Deflection} = [(D1 - D2) / D1] (100\%)$$

4.2 Record and submit all data.

5.0 DEDUCTION SCHEDULE. All pipe deductions shall be handled in accordance with the tables shown below.

FLEXIBLE PIPE DEFLECTION	
Amount of Deflection (%)	Payment
0.0 to 5.0	100% of the Unit Bid Price
5.1 to 9.9	50% of the Unit Bid Price ⁽¹⁾
10 or greater	Remove and Replace ⁽²⁾

⁽¹⁾ Provide Structural Analysis for HDPE and metal pipe. Based on the structural analysis, pipe may be allowed to remain in place at the reduced unit price. ⁽²⁾ The Department may allow the pipe to remain in place with no pay to the Contractor in instances where it is in the best interest to the public and where the structural analysis demonstrates that the pipe should function adequately.

RIGID PIPE REMEDIATION TABLE PIPE	
Crack Width (inches)	Payment
≤ 0.1	100% of the Unit Bid Price
Greater than 0.1	Remediate or Replace ⁽¹⁾

(1) Provide the Department in writing a method for repairing the observed cracking. Do not begin work until the method has been approved.

6.0 PAYMENT. The Department will measure the quantity in linear feet of pipe to inspect. The Department will make payment for the completed and accepted quantities under the following:

<u>Code</u>	<u>Pay Item</u>	<u>Pay Unit</u>
24814EC	Pipeline Inspection	Linear Foot
10065NS	Pipe Deflection Deduction	Dollars

SPECIAL NOTE FOR EXPERIMENTAL KYCT AND HAMBURG TESTING

1.0 General

1.1 Description. The KYCT (Kentucky Method for Cracking Test) and the Hamburg test results will help determine if the mixture is susceptible to cracking and rutting. During the experimental phase, data will be gathered and analyzed by the Department to determine the durability of the bituminous mixes. Additionally, the data will help the Department to create future performance-based specifications which will include the KYCT and Hamburg test methods.

2.0 Equipment

2.1 KYCT Testing Equipment. The Department will require a Marshall Test Press with digital recordation capabilities. Other CT testing equipment may be used for testing with prior approval by the Department.

2.2 Water Baths. One or more water baths will be required that can maintain a temperature of 77° +/- 1.8° F with a digital thermometer showing the water bath temperature. Also, one water bath shall have the ability to suspend gyratory specimen fully submerged in water in accordance with AASHTO T-166, current edition.

2.3 Hamburg Wheel Track Testing. The department encourages the use of the PTI APA/Hamburg Jr. test equipment to perform the loaded wheel testing. The Department will allow different equipment for the Hamburg testing, but the testing device must be approved by the Department prior to testing.

2.4 Gyratory Molds. Gyratory molds will be required to assist in the production of gyratory specimens in accordance with AASHTO T-312, current edition.

2.5 Ovens. Adequate (minimum of two ovens) will be required to accommodate the additional molds and asphalt mixture necessary to perform the acceptance testing as outlined in Section 402 of the Kentucky Standard Specifications for Road and Bridge Construction, current edition.

2.6 Department Equipment. The Department will provide gyratory molds, PINE 850 Test Press with digital recordation, and CT testing equipment to assist during this experimental phase so data can be gathered. Hamburg test specimens will be submitted to the Division of Materials for testing on the PTI APA/Hamburg Jr if the asphalt contractor or district materials office does not have an approved Hamburg testing device.

3.0 Testing Requirements

3.1 Acceptance Testing. Perform all acceptance testing and aggregate gradation as according with Section 402 and Section 403 of the Kentucky Standard Specifications for Road and Bridge Construction, current edition.

3.2 KYCT Testing. Perform crack resistance analysis (KYCT) in accordance with the current Kentucky Method for KYCT Index Testing during the mix design phase and during the plant production of all surface mixtures. For mix design approvals, submit KYCT results on the Department MixPack. For Class 4 mixtures, submit ingredient materials to the Division of Materials for verification.

3.2.1 KYCT Frequency. Obtain an adequate sample of hot mix asphalt to ensure the acceptance testing, gradation, and KYCT gyratory samples can be fabricated and is representative of the bituminous mixture. Acceptance specimens shall be fabricated first, then immediately after, fabricate the KYCT samples with the gyratory compactor in accordance with Section 2.4 of this Special Note. Analysis of the KYCT specimens and gradation will be required one per subplot produced from the same asphalt material and at the same time as the acceptance specimen is sampled and tested.

3.2.2 Number of Specimens and Conditioning. Fabricate specimens in accordance with the Kentucky Method for KYCT Index Testing. Contrary to the method, for field specimens, fabricate a minimum of 3 and up to 6 test specimens. The specimens shall be compacted at the temperature in accordance with KM 64-411. KYCT mix design specimens shall be short-term conditioned uncovered for four hours at compaction temperature in accordance with KM 64-411. Contrary to the Kentucky Method, plant produced bituminous material shall be short-term conditioned immediately after sampling for two hours uncovered in the oven at compaction temperature in accordance with KM 64-411. Additionally, fabricated specimens shall be allowed to cool in air (fan is permissible) for 30 minutes +/- 5 minutes and conditioned in a 77 °F water bath for 30 minutes +/- 5 minutes. To ensure confidence and reliability of the test results provided by KYCT testing and Hamburg testing, reheating of the asphalt mixture is prohibited.

3.2.3 Record Times. For each subplot, record the time required between drying aggregates in the plant to KYCT specimen fabrication. The production time may vary due to the time that the bituminous material is held in the silo. Record the preconditioning time when the time exceeds the one-hour specimen cool down time as required in accordance with The Kentucky Method for KYCT Index Testing. The preconditioning time may exceed an hour if the technician is unable to complete the test on the same day or within the specified times as outlined in The Kentucky Method for KYCT Index Testing. The production time and the preconditioning time shall be recorded on the AMAW.

3.2.4 File Name. As according to section 7.12 of The Kentucky Method for KYCT Index Testing, save the filename with the following format: "CID_Approved Mix Number_Lot Number_Sublot Number_Date"

3.3 Hamburg Testing. Perform the rut resistance analysis (Hamburg) in accordance with AASTHO T-324, not to exceed 20,000 passes for all bituminous mixtures during the mix design phase and production. For mix design approvals, submit Hamburg results on the Department MixPack. For Class 4 mixtures, submit ingredient materials to the Division of Materials for informational verification.

3.3.1 Hamburg Testing Frequency. Perform testing and analysis per lot of material. The plant produced bituminous material sampled for the Hamburg test does not have to be obtained at the same time as the acceptance and KYCT sample. If the Hamburg test sample is not obtained at the same time as the KYCT sample, determine the Maximum Specific Gravity of the KYCT sample in accordance with AASHTO T-209 coinciding with the Hamburg specimens.

3.3.2 Record Times. Record the production time as according to section 3.2.3 in this special note. Also record the time that the specimens were fabricated and the time the Hamburg testing was started. All times shall be recorded on the AMAW.

3.3.3 File Name. Save the Excel spreadsheet with the following file name; “Hamburg_CID_Approved Mix Number_Lot Number_Sublot Number_Date” and upload the file into the AMAW.

4.0 Data

Submit the AMAW and all test data that was obtained for acceptance, gradation, KYCT, and Hamburg testing within five working days once all testing has been completed for a lot to Central Materials Lab and the District Materials Engineer. Also, any data and or comments that the asphalt contractor or district personnel deem informational during this experimental phase, shall also be submitted to the Central Materials Lab and the District Materials Engineer. Any questions or comments regarding any item in this Special Note can be directed to the Central Office, Division of Materials, Asphalt Branch.

5.0 Payment

Any additional labor and testing equipment that is required to fabricate and test the KYCT and Hamburg specimens shall be considered incidental to the asphalt surface line item. The Department will perform the testing for the KYCT and Hamburg specimens if a producer does not possess the proper equipment.

June 15th, 2022

Special Note for Bridge Demolition, Renovation and Asbestos Abatement

If the project includes any bridge demolition or renovation, the successful bidder is required to notify Kentucky Division for Air Quality (KDAQ) via filing of form (DEP 7036) a minimum of 10 working days prior to commencement of any bridge demolition or renovation work.

Any available information regarding possible asbestos containing materials (ACM) on or within bridges to be affected by the project has been included in the bid documents. These are to be included with the Contractor's notification filed with the KDAQ. If not included in the bid documents, the Department will provide that information to the successful bidder for inclusion in the KDAQ notice as soon as possible. If there are no documents stating otherwise, the bidders should assume there are no asbestos containing materials that will in any way affect the work.



COMMONWEALTH OF KENTUCKY
TRANSPORTATION CABINET
transportation.ky.gov

Andy Beshear
GOVERNOR

Jim Gray
SECRETARY

Asbestos Inspection Report

To: Josh Higgins

District: 11

Date: June 23, 2022

Conducted By: O'Dail Lawson

Report Prepared By: O'Dail Lawson

Project and Structure Identification

Project Number: Laurel 11-0185

Structure ID: 063B00007N

Structure Location: KY 1223N over Horse Creek

Sample Description: Any suspect materials collected were negative for asbestos.

Inspection Date: June 22, 2022

Results and Recommendations

The results of the samples collected were negative for the presence of asbestos above 1%.
No abatement is required at this time.

It is recommended that this report accompany the 10-Day Notice of Intent for Demolition ([Notification Form DEP 7036](#)) which is to be submitted to the Kentucky Division of Air Quality prior to abatement, demolition, or renovation of any building or structure in the Commonwealth.

MRS, INC. *MRS, Inc. Analytical Laboratory Division*

332 West Broadway / Suite # 902
Louisville, Kentucky - 40202 - 2133

(502) 495-1212
Fax: (502) 491-7111

BULK SAMPLE ASBESTOS ANALYSIS

Analysis N# # 3206232 Address: Laurel 11-185 063B00007N
 Client Name: K Y T C
 Sampled By: O'Dail Lawson

		% FIBROUS ASBESTOS				% NON-ASBESTOS FIBERS					
Sample ID	Color	Layered	Fibrous	Chrysotile	Amosite	crocidolite	Others	Cellulose	Fiberglass	Syn. Fiber	Other/Mat.
# L - 1	Brown	Yes	No				None				100%

Methodology : EPA Method 600/R-93-116
 Date Analyzed : 23-Jun-22
 Analyst : Winterford Mensah

Reviewed By: 
Signature

The test relates only to the items tested. This report does not represent endorsement by NVLAP or any agency of the U.S Government. Partial Reproduction of any part of this report is strictly prohibited. Samples shall be retained for (30) days.



Chain of Custody Record

Kentucky Transportation Cabinet

200 Mero Street, 5th Floor West
Frankfort, Kentucky 40622
(502) 564-7250 fax (502) 564-5655

O'Dail Lawson o'dail.lawson@ky.gov W4-06-06 200 Mero Street Frankfort KY Phone: 502-782-5020 Fax: 502-564-5655 N/A = Not Applicable PO#:		Client Information KY TRANSPORTATION CABINET Results Code: KY-1223 over Horse Creek. Samplers (signature):	
Project ID: LAUREL 11-185	Collected Date: 6/22/22	Collected Time: 10:46	Analysis Requested: Asbestos, bulk
Sample ID: L1	Sample Description: Mortar (Block Abutment)	Matrix: Mortar	Color: brown
			Cont. Type: N/A
			Preservative:
Relinquished By:		Date/Time:	
Received By:		Date/Time: 6/22/22	
Relinquished By:		Date/Time:	
Received at Lab By:		Date/Time:	

ENVIRONMENTAL TRAINING CONCEPTS, INC
P. O. Box 99603 Louisville, KY 40269
(502)640-2951

Certification Number: FTC-AIR-031522-00137

O'Dail Lawson

has on 03-15-2022, attended and successfully completed the requirements and passed the examination with a score of 70% of better on the entitled course.

ASBESTOS INSPECTOR REFRESHER

Training was in accordance with 40 CFR Part 763 (AHERA) approved by the Commonwealth of Kentucky, the Indiana Department of Environmental Management, Tennessee Department of Environment & Conservation and The Arkansas Department of Environmental Quality. The above student received requisite training for Asbestos Accreditation under Title II of the Toxic Substance Act (TSCA).

Conducted at: 1220 KY Mills Drive, Louisville, KY

Name - Training Manager

Expiration Date: 03-15-2023

Name - Instructor

	KENTUCKY TRANSPORTATION CABINET Department of Highways DIVISION OF RIGHT OF WAY & UTILITIES RIGHT OF WAY CERTIFICATION	TC 62-226 Rev. 01/2016 Page 1 of 1
--	--	--

<input checked="" type="checkbox"/> Original		<input type="checkbox"/> Re-Certification		RIGHT OF WAY CERTIFICATION			
ITEM #	COUNTY	PROJECT # (STATE)	PROJECT # (FEDERAL)				
11-185.00	Laurel	063 0025 000-002	NHPP 0251 036 NHPP 0251 037				

PROJECT DESCRIPTION

MAJOR WIDENING - ADDRESS SAFETY, CAPACITY, AND ACCESS MANAGEMENT ON US 25E FROM KNOX/LAUREL COUNTY LINE TO KY 770. Project Length 2.024 miles

No Additional Right of Way Required

Construction will be within the limits of the existing right of way. The right of way was acquired in accordance to FHWA regulations under the Uniform Relocation Assistance and Real Property Acquisitions Policy Act of 1970, as amended. No additional right of way or relocation assistance were required for this project.

Condition # 1 (Additional Right of Way Required and Cleared)

All necessary right of way, including control of access rights when applicable, have been acquired including legal and physical possession. Trial or appeal of cases may be pending in court but legal possession has been obtained. There may be some improvements remaining on the right-of-way, but all occupants have vacated the lands and improvements, and KYTC has physical possession and the rights to remove, salvage, or demolish all improvements and enter on all land. Just Compensation has been paid or deposited with the court. All relocations have been relocated to decent, safe, and sanitary housing or that KYTC has made available to displaced persons adequate replacement housing in accordance with the provisions of the current FHWA directive.

Condition # 2 (Additional Right of Way Required with Exception)

The right of way has not been fully acquired, the right to occupy and to use all rights-of-way required for the proper execution of the project has been acquired. Some parcels may be pending in court and on other parcels full legal possession has not been obtained, but right of entry has been obtained, the occupants of all lands and improvements have vacated, and KYTC has physical possession and right to remove, salvage, or demolish all improvements. Just Compensation has been paid or deposited with the court for most parcels. Just Compensation for all pending parcels will be paid or deposited with the court prior to AWARD of construction contract

Condition # 3 (Additional Right of Way Required with Exception)

The acquisition or right of occupancy and use of a few remaining parcels are not complete and/or some parcels still have occupants. All remaining occupants have had replacement housing made available to them in accordance with 49 CFR 24.204. KYTC is hereby requesting authorization to advertise this project for bids and to proceed with bid letting even though the necessary right of way will not be fully acquired, and/or some occupants will not be relocated, and/or the just compensation will not be paid or deposited with the court for some parcels until after bid letting. KYTC will fully meet all the requirements outlined in 23 CFR 635.309(c)(3) and 49 CFR 24.102(j) and will expedite completion of all acquisitions, relocations, and full payments after bid letting and prior to AWARD of the construction contract or force account construction.

Total Number of Parcels on Project	50	EXCEPTION (S) Parcel #	ANTICIPATED DATE OF POSSESSION WITH EXPLANATION
Number of Parcels That Have Been Acquired			
Signed Deed	40		
Condemnation	10	Parcel 12	Right of Entry Obtained on 9 parcels Parcel #12 was eliminated from project
Signed ROE	10	Parcel 12	Signed ROE on 9 parcels Parcel #12 eliminated from project post mediation

Notes/ Comments (Use Additional Sheet if necessary)

LPA RW Project Manager		Right of Way Supervisor	
Printed Name		Printed Name	Greg Combs
Signature		Signature	 2020.04.13 19:01:00
Date		Date	-04'00'
Right of Way Director		FHWA	
Printed Name	DM Loy	Printed Name	No Signature Required
Signature	Digitally signed by DM Loy Date: 2020.04.13 06:44:13 -04'00'	Signature	as per FHWA-KYTC Current Stewardship Agreement

UTILITIES AND RAIL CERTIFICATION NOTE

Laurel County, NHPP0251037
FD52 063 86576 01U
IMPROVE SAFETY, IMPROVE ACCESS MANAGEMENT, AND REDUCE CONGESTION ON US25E FROM THE
KNOX/LAUREL COUNTY LINE TO KY770
ITEM NUMBER: 11-185.00

PROJECT NOTES ON UTILITIES

The contractor should be aware that there is UTILITY WORK INCLUDED IN THIS ROAD CONSTRUCTION CONTRACT. The Contractor shall review the GENERAL UTILITY NOTES AND INSTRUCTIONS which may include KYTC Utility Bid Item Descriptions, utility owner supplied specifications, plans, list of utility owner preapproved subcontractors, and other instructions. Utility contractors may be added via addendum if KYTC is instructed to do so by the utility owner. Potential contractors must seek prequalification from the utility owner. Any revisions must be sent from the utility owner to KYTC a minimum of one week prior to bid opening.

For all projects over 2000 linear feet, which are defined as a "Large Project" in KRS 367.4903(18), the awarded contractor shall initially mark the first 2000 linear feet minimally of proposed excavation or construction boundaries of the project to be worked using the procedure set forth in KRS 367.4909(9)(k). This temporary field locating of the project excavation boundary shall take place prior to submitting an excavation location request to the underground utility protection Kentucky Contact Center. For large projects, the awarded contractor shall work with the impacted utilities to determine when additional white lining of the remainder of the project site will take place. This provision shall not alter or relieve the awarded contractor from complying with requirements of KRS 367.4905 to 367.4917 in their entirety.

Please Note: The information presented in this Utility Note is informational in nature and the information contained herein is not guaranteed.

The contractor will be responsible for contacting all utility facility owners on the subject project to coordinate his activities. The contractor will coordinate his activities to minimize and, where possible, avoid conflicts with utility facilities. Due to the nature of the work proposed, it is unlikely to conflict with the existing utilities beyond minor facility adjustments. Where conflicts with utility facilities are unavoidable, the contractor will coordinate any necessary relocation work with the facility owner and Resident Engineer. The Kentucky Transportation Cabinet maintains the right to remove or alter portions of this contract if a utility conflict occurs. The utility facilities as noted in the previous section(s) have been determined using data garnered by varied means and with varying degrees of accuracy: from the facility owners, a result of S.U.E., field inspections, and/or reviews of record drawings. The facilities defined may not be inclusive of all utilities in the project scope and are not Level A quality, unless specified as such. It is the contractor's responsibility to verify all utilities and their respective locations before excavating.

The contractor shall make every effort to protect underground facilities from damage as prescribed in the Underground Facility Damage Protection Act of 1994, Kentucky Revised Statute KRS 367.4901 to 367.4917. It is the contractor's responsibility to determine and take steps necessary to be in compliance

UTILITIES AND RAIL CERTIFICATION NOTE

**Laurel County, NHPP0251037
FD52 063 86576 01U
IMPROVE SAFETY, IMPROVE ACCESS MANAGEMENT, AND REDUCE CONGESTION ON US25E FROM THE
KNOX/LAUREL COUNTY LINE TO KY770
ITEM NUMBER: 11-185.00**

with federal and state damage prevention directives. The contractor is instructed to contact KY 811 for the location of existing underground utilities. Contact shall be made a minimum of two (2) and no more than ten (10) business days prior to excavation. The contractor shall submit Excavation Locate Requests to the Kentucky Contact Center (KY 811) via web ticket entry. The submission of this request does not relieve the contractor from the responsibility of contacting non-member facility owners, whom are to be contacted through their individual Protection Notification Center. It may be necessary for the contractor to contact the County Court Clerk to determine what utility companies have facilities in the area. Non-compliance with these directives can result in the enforcement of penalties.

NOTE: DO NOT DISTURB THE FOLLOWING FACILITIES LOCATED WITHIN THE PROJECT DISTURB LIMITS

KU has an existing pole at LT 32+90 just inside the disturbed limits that will remain in place. They have relocated a pole at Dorthae Road RT STA 9+55 adjacent to the proposed Marathon entrance. These poles will need to be worked around.

The Contractor is fully responsible for protection of all utilities listed above

THE FOLLOWING FACILITY OWNERS ARE RELOCATING/ADJUSTING THEIR FACILITIES WITHIN THE PROJECT LIMITS AND WILL BE COMPLETE PRIOR TO CONSTRUCTION

KU, Charter, and AT&T have relocated their overhead facilities to be clear of roadwork. AT&T has also relocated underground facilities in the area of RT STA 167+00 – 175+00. Relocation plans can be provided, however, facilities as they exist in the field would supersede locations shown on plans and must be accommodated as they exist.

Delta Gas has relocated underground facilities throughout most of the project. Relocation plans can be provided.

THE FOLLOWING FACILITY OWNERS HAVE FACILITIES TO BE RELOCATED/ADJUSTED BY THE OWNER OR THEIR SUBCONTRACTOR AND IS TO BE COORDINATED WITH THE ROAD CONTRACT

N/A

UTILITIES AND RAIL CERTIFICATION NOTE

**Laurel County, NHPP0251037
FD52 063 86576 01U
IMPROVE SAFETY, IMPROVE ACCESS MANAGEMENT, AND REDUCE CONGESTION ON US25E FROM THE
KNOX/LAUREL COUNTY LINE TO KY770
ITEM NUMBER: 11-185.00**

**THE FOLLOWING FACILITY OWNERS HAVE FACILITIES TO BE RELOCATED/ADJUSTED BY THE ROAD
CONTRACTOR AS INCLUDED IN THIS CONTRACT**

Relocation of Corbin City Utilities, Barbourville Utility Commission, and Laurel County Water District #2 facilities will be performed as part of the road contract as specified in the utility relocation plans. Approved contractors for each company are listed in the General Utility Notes included in the proposal. Coordinate work with each company.

RAIL COMPANIES HAVE FACILITIES IN CONJUNCTION WITH THIS PROJECT AS NOTED

No Rail Involvement **Rail Involved** **Rail Adjacent**

UTILITIES AND RAIL CERTIFICATION NOTE

Laurel County, NHPP0251037
FD52 063 86576 01U
IMPROVE SAFETY, IMPROVE ACCESS MANAGEMENT, AND REDUCE CONGESTION ON US25E FROM THE
KNOX/LAUREL COUNTY LINE TO KY770
ITEM NUMBER: 11-185.00

AREA FACILITY OWNER CONTACT LIST

<u>Utility Company/Agency</u>	<u>Contact Name</u>	<u>Contact Information</u>
Barbourville Utilities	Josh Callihan	606-546-3187
Corbin Utilities	Ron Herd	606-528-4026
LWD#2	Ken Fisher	606-878-2494
Delta Gas	Brent Means	859-744-6171x1134
CVRECC	Mark Abner	606-546-9295
Windstream	Mark Ware	606-329-6195
Charter	William Clark	606-416-9212
KU	Chad Francisco	606-864-2821
AT&T	Kenny Dunn	859-583-3780

GENERAL UTILITY NOTES AND INSTRUCTIONS APPLICABLE TO ALL UTILITY WORK MADE A PART OF THE ROAD CONSTRUCTION CONTRACT

The contractor should be aware the following utility notes and KYTC Utility Bid Item Descriptions shall supersede, replace, and take precedence over any and all conflicting information that may be contained in utility owner supplied specifications contained in the contract, on plans supplied by the utility owner, or any utility owner specifications or information externally referenced in this contract.

Where information may have been omitted from these notes, bid item descriptions, utility owner supplied specifications or plans; the KYTC Standard Specifications for Road and Bridge Construction shall be referenced.

PROTECTION OF EXISTING UTILITIES

The existing utilities shown on the plans are shown as best known at the time the plans were developed and are to be used as a guide only by the Contractor. The Contractor shall use all means at his disposal to accurately locate all existing utilities, whether shown on the plans or not, prior to excavation. The contractor shall protect these utilities during construction. Any damage to existing utilities during construction that are shown or not shown on the plans shall be repaired at the Contractor's expense.

PREQUALIFIED UTILITY CONTRACTORS

Some utility owners may require contractors that perform relocation work on their respective facilities as a part of the road contract be prequalified or preapproved by the utility owner. **Utility contractors may be added via addendum if KYTC is instructed to do so by the utility owner. Potential contractors must seek prequalification from the utility owner. Any revisions must be sent from the utility owner to KYTC a minimum of one week prior to bid opening.** Those utility owners with a prequalification or preapproval requirement are as follows:

**Barbourville & Corbin City
Utilities:**

Akins Excavating Co., Inc.
182 Busy Lane
Corbin, KY 40701
606-528-9144

Edward Hall Trucking &
Excavation
110 Northland Drive
Corbin, KY 40701
606-523-5037

Flo-Line Contracting LLC
189 Sunstar Blvd.
Monticello, KY 42633
606-340-8000

Grant's Excavating, Inc.
P.O. Box 298
2006 Corporate Drive Suite 1
Richmond, KY 40476
859-626-3478

K. Carrender Construction Co.,
Inc.
299 Ringgold Drive
Somerset, KY 42503
606-679-2328

Laurel Water District #2:

Akins Excavating Co., Inc.
182 Busy Lane
Corbin, KY 40701
(606)528-9144

Flo-Line Contracting LLC
189 Sunstar Blvd.
Monticello, KY 42633
606-340-8000

Stotts Construction Company
203 Burkesville St Ste 17
Columbia, KY, KY 42728
270-384-2677

The bidding contractor needs to review the above list and choose from the list of approved subcontractors at the end of these general notes as identified above before bidding. When the list of approved subcontractors is provided, only subcontractors shown on the following list(s) will be allowed to work on that utility as a part of this contract.

When the list of approved subcontractors for the utility work is not provided in these general notes, the utility work can be completed by the prime contractor. If the prime contractor chooses to subcontract the work, the subcontractor shall be prequalified with the KYTC Division of Construction Procurement in the work type of "Utilities" (I33). Those who would like to become prequalified may contact the Division of Construction Procurement at (502) 564-3500. Please note: it could take up to 30 calendar days for prequalification to be approved. The prequalification does not have to be approved prior to the bid, but must be approved before the subcontract will be approved by KYTC and the work can be performed.

CONTRACT ADMINISTRATION RELATIVE TO UTILITY WORK

All utility work is being performed as a part of a contract administered by KYTC; there is not a direct contract between the utility contractor and utility owner. The KYTC Section Engineer is ultimately responsible for the administration of the road contract and any utility work included in the contract.

SUBMITTALS AND CORRESPONDENCE

All submittals and correspondence of any kind relative to utility work included in the road contract shall be directed to the KYTC Section Engineer, a copy of which may also be supplied to the utility owner by the contractor to expedite handling of items like material approvals and shop drawings. All approvals and correspondence generated by the utility owner shall be directed to the KYTC Section Engineer. The KYTC Section Engineer will relay any approvals or correspondence to the utility contractor as appropriate. At no time shall any direct communication between the utility owner and utility contractor without the communication flowing through the KYTC Section Engineer be considered official and binding under the contract.

ENGINEER

Where the word “Engineer” appears in any utility owner specifications included in this proposal, utility owner specifications included as a part of this contract by reference or on the utility relocation plans, it shall be understood the “Engineer” is the Kentucky Transportation Cabinet (KYTC) Section Engineer or designated representative and the utility owner engineer or designated representative jointly. Both engineers must mutually agree upon all decisions made with regard to the utility construction. The Transportation Cabinet, Section Engineer shall make all final decisions in all disputes.

INSPECTOR OR RESIDENT PROJECT REPRESENTATIVE

Where the word “Inspector” or “Resident Project Representative” appears in the utility specifications included in this proposal, utility owner specifications included as a part of this contract by reference or on the utility relocation plans, it shall be understood the “Inspector” or “Resident Project Representative” is the utility owner inspector and KYTC inspector jointly. The Transportation Cabinet, Section Engineer shall make all final decisions in all disputes.

NOTICE TO UTILITY OWNERS OF THE START OF WORK

One month before construction is to start on a utility, the utility contractor shall make notice to the KYTC Section Engineer and the utility owner of when work on a utility is anticipated to start. The utility contractor shall again make confirmation notice to the KYTC Section Engineer and the utility owner one week before utility work is to actually start.

UTILITY SHUTDOWNS

The Contractor shall not shut down any active and in-service mains, utility lines or services for any reason unless specifically given permission to do so by the utility owner. The opening and closing of valves and operating of other active utility facilities for main, utility line or utility service shut downs are to be performed by the utility owner unless specific permission is given to the contractor by the owner to make shutdowns. If and when the utility owner gives the contractor permission to shutdown mains, utility lines or utility services, the contractor shall do so following the rules, procedures and regulations of the utility owner. Any permission given by the utility owner to the contractor to shutdown active and in-service mains, utility lines or services shall be communicated to the KYTC Section Engineer by the utility owner that such permission has been given.

Notice to customers of utility shut downs is sometimes required to be performed by the utility contractor. The contractor may be required; but, is not limited to, making notice to utility customers in a certain minimum amount of time in advance of the shut down and by whatever means of communication specified by the utility owner. The means of communication to the customer may be; but is not limited to, a door hanger, notice by newspaper ad, telephone contact, or any combination of communication methods deemed necessary, customary and appropriate by the utility owner. The contractor should refer to the utility owner specifications for requirements on customer notice.

Any procedure the utility owner may require the contractor to perform by specification or plan note and any expense the contractor may incur to comply with the utility owner's shut down procedure and notice to customers shall be considered an incidental expense to the utility construction.

CUSTOMER SERVICE AND LATERAL ABANDONMENTS When temporary or permanent abandonment of customer water, gas, or sewer services or laterals are necessary during relocation of utilities included in the contract, the utility contractor shall perform these abandonments as part of the contract as incidental work. No separate payment will be made for service line and lateral abandonments. The contractor shall provide all labor, equipment and materials to accomplish the temporary or permanent abandonment in accordance with the plans, specifications and/or as directed by the engineer. Abandonment may include, but is not limited to, digging down on a water or gas main at the tap to turn off the tap valve or corporation stop and/or capping or plugging the tap, digging down on a sewer tap at the main and plugging or capping the tap, digging down on a service line or lateral at a location shown on the plans or agreeable to the engineer and capping or plugging, or performing any other work necessary to abandon the service or lateral to satisfactorily accomplish the final utility relocation.

STATIONS AND DISTANCES

All stations and distances, when indicated for utility placement in utility relocation plans or specifications, are approximate; therefore, some minor adjustment may have to be made during construction to fit actual field conditions. Any changes in excess of 6 inches of plan location shall be reviewed and approved jointly by the KYTC Section Engineer or designated representative and utility owner engineer or designated representative. Changes in location without prior approval shall be remedied by the contractor at his own expense if the unauthorized change creates an unacceptable conflict or condition.

RESTORATION

Temporary and permanent restoration of paved or stone areas due to utility construction shall be considered incidental to the utility work. No separate payment will be made for this work. Temporary restoration shall be as directed by the KYTC Section Engineer. Permanent restoration shall be “in-kind” as existing.

Restoration of seed and sod areas will be measured and paid under the appropriate seeding and sodding bid items established in the contract for roadway work.

Standard Water Bid Item Descriptions

W AIR RELEASE VALVE This bid item description shall apply to all air release valve installations of every size except those defined as “Special”. This item shall include the air release valve, main to valve connecting line or piping, manhole, vault, structure, access casting or doors, tapping the main, labor, equipment, excavation, proper backfill and restoration required to install the air release valve at the location shown on the plans or as directed in accordance with the specifications and standard drawings complete and ready for use. All air release/vacuum valves on a project shall be paid under one bid item regardless of size. No separate pay items will be established for size variations. Only in the case of the uniqueness of a particular air release valve would a separate bid item be established. Please refer to the Utility Company’s Specifications. If the Company does not have specifications, KYTC’s Specifications shall be referenced. This item shall be paid EACH (EA) when complete.

BOLLARDS This item is for payment for furnishing and installing protective guard posts at above ground utility installations. A bollard may consist of, but not limited to, a steel post set in concrete or any other substantial post material. This item shall include all labor, equipment, and materials needed for complete installation of the bollard as specified by the utility owner specifications and plans. If the Company does not have specifications, KYTC’s Specifications shall be referenced. This item shall be paid EACH (EA) when complete.

NOTE: A bid code for this item has been established in standard roadway bid items and shall be used for payment of this item. The bid code is 21341ND

W CAP EXISTING MAIN This item shall include the specified cap, concrete blocking and/or mechanical anchoring, labor, equipment, excavation, backfill, and restoration required to install the cap at the location shown on the plans or as directed in accordance with the specifications. This item is not to be paid on new main installations. This pay item is only to be paid to cap existing mains. Caps on new mains are incidental to the new main. Any and all caps on existing mains shall be paid under one bid item included in the contract regardless of size. No separate bid items will be established for size variations. Please refer to the Utility Company’s Specifications. If the Company does not have specifications, KYTC’s Specifications shall be referenced. This item shall be paid EACH (EA) when complete.

W DIRECTIONAL BORE Payment under this item is made whenever the plans or specifications specifically show directional boring is to be utilized in order to minimize the impact of open cut for the installation of water main under streets, creeks, and etc. Payment under this item shall include the specified bore pipe, labor, and equipment. No separate payment shall be made for bore pipe installed in the bore whether used as a carrier pipe or an encasement of a separate carrier pipe. This item shall also include pipe anchors at each end of the bore when specified to prevent the creep or contraction of the bore pipe. Carrier pipe installed within a bore pipe shall be paid separately under pipe items. Payment under this item shall not be size specific and no separate bid items will be established for size variations. The bore pipe sizes to be included under this item shall be as shown on the plans and/or in the specifications. Any and all directional bores in each contract shall be paid under one directional bore bid item included in the contract regardless of size. Please refer to the Utility Company’s Specifications. If the Company does not have specifications, KYTC’s Specifications shall be referenced. This item shall be paid LINEAR FEET (LF) when complete.

W ENCASUREMENT CONCRETE Includes all labor, equipment, excavation, concrete, reinforcing steel, backfill, restoration, and etc., to construct the concrete encasement of the water main as shown on the plans, and in accordance with the specifications and standard drawings. Payment under this item shall be in addition to the carrier pipe as paid under separate bid items. Carrier pipe is not included in this bid item. Any and all concrete encasement shall be paid under one bid item included in the contract regardless of the size of the carrier pipe or the volume of concrete or steel reinforcement as specified in the plans and specifications. No separate bid items will be established for size variations. Measurement of pay quantity shall be from end of concrete to end of concrete. Please refer to the Utility Company's Specifications. If the Company does not have specifications, KYTC's Specifications shall be referenced. This item shall be paid LINEAR FEET (LF) when complete.

W ENCASUREMENT STEEL BORED This item shall include the steel encasement pipe size as specified on the plans and in the specifications, casing spacers, end seals, labor, and equipment to bore and install the encasement in accordance with the plans and specifications, complete and ready for use. The size shall be the measured internal diameter of the encasement pipe. The sizes of encasement to be paid under the size ranges specified in the bid items shall be as follows:

- Range 1 = All encasement sizes greater than 2 inches to and including 6 inches
- Range 2 = All encasement sizes greater than 6 inches to and including 10 inches
- Range 3 = All encasement sizes greater than 10 inches to and including 14 inches
- Range 4 = All encasement sizes greater than 14 inches to and including 18 inches
- Range 5 = All encasement sizes greater than 18 inches to and including 24 inches
- Range 6 = All encasement sizes greater than 24 inches

(Encasement sizes of 2 inches internal diameter or less shall not be paid separately; but, shall be considered incidental to the carrier pipe.) Payment under this bid item shall not include the carrier pipe. Carrier pipe shall be paid under a separate bid item. Please refer to the Utility Company's Specifications. If the Company does not have specifications, KYTC's Specifications shall be referenced. This item shall be paid LINEAR FEET (LF) when complete.

W ENCASUREMENT STEEL OPEN CUT This item shall include the steel encasement pipe size as specified on the plans and in the specifications, casing spacers, end seals, labor, and equipment to open cut and install the encasement in accordance with the plans and specifications, complete and ready for use. The size shall be the measured internal diameter of the encasement pipe. The size encasement to be paid under the size ranges specified in the bid items shall be as follows:

- Range 1 = All encasement sizes greater than 2 inches to and including 6 inches
- Range 2 = All encasement sizes greater than 6 inches to and including 10 inches
- Range 3 = All encasement sizes greater than 10 inches to and including 14 inches
- Range 4 = All encasement sizes greater than 14 inches to and including 18 inches
- Range 5 = All encasement sizes greater than 18 inches to and including 24 inches
- Range 6 = All encasement sizes greater than 24 inches

(Encasement sizes of 2 inches internal diameter or less shall not be paid separately; but, shall be considered incidental to the carrier pipe.) Payment under this bid item shall not include the carrier pipe. Carrier pipe shall be paid under a separate bid item. Please refer to the Utility Company's Specifications. If the Company does not have specifications, KYTC's Specifications shall be referenced. This item shall be paid LINEAR FEET (LF) when complete.

W FIRE HYDRANT ADJUST Includes all labor, equipment, excavation, materials, and backfill to adjust the existing fire hydrant using the fire hydrant manufacturer's extension kit for adjustments of 18" or less. Adjustments greater than 18" require anchoring couplings and vertical bends to adjust to grade. The Contractor will supply and install all anchor couplings, bends, fire hydrant extension, concrete blocking, restoration, granular drainage material, etc, needed to adjust the fire hydrant complete and ready for use as shown on the plans, and in accordance with the specifications and standard drawings. This also includes allowing for the utility owner inspector to inspect the existing fire hydrant prior to adjusting, contractor returning unusable fire hydrants to the utility owner warehouse and picking up a replacement hydrant. No additional payment will be made for rock excavation. Please refer to the Utility Company's Specifications. If the Company does not have specifications, KYTC's Specifications shall be referenced. This item shall be paid EACH (EA) when complete and ready for use.

W FIRE HYDRANT ASSEMBLY Includes all labor, equipment, new fire hydrant, isolating valve and valve box, concrete pad around valve box (when specified in specifications or plans), piping, anchoring tee, anchoring couplings, fire hydrant extension, excavation, concrete blocking, granular drainage material, backfill, and restoration, to install a new fire hydrant assembly as indicated on plans and on standard drawings complete and ready for use. No additional payment will be made for rock excavation. Please refer to the Utility Company's Specifications. If the Company does not have specifications, KYTC's Specifications shall be referenced. This item shall be paid EACH (EA) when complete.

W FIRE HYDRANT RELOCATE This item includes all labor and equipment to remove the existing fire hydrant from its existing location and reinstalling at a new location. This item shall include a new isolating valve and valve box, concrete pad around valve box (when required in specifications or plans), new piping, new anchoring tee, anchoring couplings, fire hydrant extensions, concrete blocking, restoration, granular drainage material, excavation, and backfill as indicated on plans, specifications, and on standard drawings complete and ready for use. This item shall also include allowing for utility owner inspector to inspect the existing fire hydrant prior to reuse, contractor returning unusable fire hydrants to the utility owner warehouse and picking up a replacement hydrant for use, if the existing fire hydrant is determined unfit for reuse. No additional payment will be made for rock excavation. Please refer to the Utility Company's Specifications. If the Company does not have specifications, KYTC's Specifications shall be referenced. This item shall be paid EACH (EA) when complete.

W FIRE HYDRANT REMOVE This bid item includes removal of an abandoned fire hydrant, isolating valve, and valve box to the satisfaction of the engineer. The removed fire hydrant, isolating valve and valve box shall become the property of the contractor for his disposal as salvage or scrap. Please refer to the Utility Company's Specifications. If the Company does not have specifications, KYTC's Specifications shall be referenced. This item shall be paid EACH (EA) when complete.

W FLUSH HYDRANT ASSEMBLY This item shall include the flushing hydrant assembly, service line, tapping the main, labor, equipment, excavation, backfill, and restoration required to install the flush hydrant at the location shown on the plans and in accordance with the specifications and standard drawings, complete and ready for use. Please refer to the Utility Company's Specifications. If the Company does not have specifications, KYTC's Specifications shall be referenced. This item shall be paid EACH (EA) when complete.

W FLUSHING ASSEMBLY This item shall include the flushing device assembly, service line, meter box and lid, tapping the main, labor, equipment, excavation, backfill, and restoration required to install the

flushing device at the location shown on the plans and in accordance with the specifications and standard drawings, complete and ready for use. Please refer to the Utility Company's Specifications. If the Company does not have specifications, KYTC's Specifications shall be referenced. This item shall be paid EACH (EA) when complete.

W LEAK DETECTION METER This item is for payment for installation of a water meter at main valve locations where shown on the plans for detection of water main leaks. The meter shall be of the size and type specified in the plans or specifications. This item shall include all labor, equipment, meter, meter box or vault, connecting pipes between main and meter, main taps, tapping saddles, casting, yoke, and any other associated material needed for installation of a functioning water meter in accordance with the plans and specifications, complete and ready for use. No separate payment will be made under any other contract item for connecting pipe or main taps. Any and all leak detection meters shall be paid under one bid item included in the contract regardless of size. No separate bid items will be established for size variations. Please refer to the Utility Company's Specifications. If the Company does not have specifications, KYTC's Specifications shall be referenced. This item shall be paid EACH (EA) when complete and ready for use.

W LINE MARKER This item is for payment for furnishing and installing a water utility line marker as specified by the utility owner specifications and plans. A line marker may consist of a post or monument of whatever materials specified and shall include markings and/or signage on same as specified by plans or specifications. This item shall include all labor, equipment, and materials needed for complete installation of the marker. This item shall be paid EACH (EA) when complete.

W MAIN POINT RELOCATE This item is intended for payment for horizontal and/or vertical relocation of a short length of an existing main at the locations shown on the plans. This bid item is to be used to relocate an existing water main at point locations such as to clear a conflict at a proposed drainage structure, pipe or any other similar short relocation situation, and where the existing pipe material is to be reused. The contractor shall provide any additional pipe or fitting material needed to complete the work as shown on the plans and specifications. The materials provided shall be of the same type and specification as those that exist. Substitution of alternative materials shall be approved by the engineer in advance on a case by case basis. New polyethylene wrap is to be provided (if wrap exists or is specified in the specifications to be used). If it is necessary that the pipe be disassembled for relay, payment under this item shall also include replacement of joint gaskets as needed. Bedding and backfill shall be provided and performed the same as with any other pipe installation as detailed in the plans and specifications. Payment under this item shall be for each location requiring an existing main to be relocated horizontally or vertically regardless of pipe size or relocation length. No separate pay items will be established for pipe size variations or relocation segment length variations. Water Main Relocate shall not be paid on a linear feet basis; but, shall be Paid EACH (EA) at each location when complete and placed in service. Please refer to the Utility Company's Specifications. If the Company does not have specifications, KYTC's Specifications shall be referenced.

W METER This item is for payment for installation of all standard water meters of all sizes 2 inches ID or less as specified on the plans. This item shall include all labor, equipment, meter, meter box, casting, yoke, and any other associated material needed for installation of a functioning water meter in accordance with the plans and specifications, complete and ready for use. This item shall include connections to the new or existing water service line. Please refer to the Utility Company's Specifications. If the Company does not have specifications, KYTC's Specifications shall be referenced. This item shall be paid EACH (EA) when complete.

W METER ADJUST This item includes all labor, equipment, excavation, materials, backfill, restoration, and etc., to adjust the meter casting to finished grade (whatever size exists) at the location shown on the plans or as directed in accordance with the specifications and standard drawings complete and ready for use. Please refer to the Utility Company's Specifications. If the Company does not have specifications, KYTC's Specifications shall be referenced. This item shall be paid EACH (EA) when complete.

W METER RELOCATE This item includes all labor, equipment, excavation, additional fittings, disinfection, testing, restoration, and etc., to relocate the existing water meter (whatever size exists), meter yoke, meter box, casting, and etc., from its old location to the location shown on the plans or as directed, in accordance with the specifications and standard drawings complete and ready for use. The new service pipe (if required) will be paid under short side or long side service bid items. Any and all meter relocations of 2 inches or less shall be paid under one bid item included in the contract regardless of size. Each individual relocation shall be paid individually under this item; however, no separate bid items will be established for meter size variations of 2 inches ID or less. Please refer to the Utility Company's Specifications. If the Company does not have specifications, KYTC's Specifications shall be referenced. This item shall be paid EACH (EA) when complete.

W METER VAULT SIZE RANGE 1 OR 2 This item is for payment for installation of an underground structure for housing of a larger water meter, fittings, and valves as required by the plans and specifications. This item shall include all labor, equipment, excavation, concrete, manhole castings or access doors, the specified meter(s) valve(s), all piping, and fitting materials associated with installing a functioning meter and vault in accordance with the plans, standard drawings, and specifications, complete and ready for use. The size shall be the measured internal diameter of the meter and piping to be installed. The size meter vault to be paid under size 1 or 2 shall be as follows:

- Size Range 1 = All meter and piping sizes greater than 2 inches up to and including 6 inches
- Size Range 2 = All meter and piping sizes greater than 6 inches

This item shall be paid EACH (EA) when complete. Please refer to the Utility Company's Specifications. If the Company does not have specifications, KYTC's Specifications shall be referenced.

W METER/FIRE SERVICE COMBO VAULT This item is for payment for installation of an underground structure for housing of a water meter and fire service piping, fittings, and valves as required by the plans and specifications. This item shall include all labor, equipment, excavation, concrete, manhole castings or access doors, the specified meter(s), valve(s), all piping, and fitting materials associated with installing a functioning meter and fire service vault in accordance with the plans and specifications, complete and ready for use. Please refer to the Utility Company's Specifications. If the Company does not have specifications, KYTC's Specifications shall be referenced. This item shall be paid EACH (EA) when complete.

W METER WITH PRESSURE REDUCING VALVE (PRV) This item is for payment for installation of all standard water meters with pressure reducing valves (PRV) of all sizes 2 inches ID or less as specified on the plans. This item shall include all labor, equipment, meter, PRV, meter box, casting, yoke, and any other associated material needed for installation of a functioning water meter with PRV in accordance with the plans and specifications, complete and ready for use. This item shall include connections to the new or existing water service line. Please refer to the Utility Company's Specifications. If the Company does not have specifications, KYTC's Specifications shall be referenced.

This item shall be paid EACH (EA) when complete.

W PIPE This description shall apply to all PVC, ductile iron, and polyethylene/plastic pipe bid items of every size and type to be used as water main, except those bid items defined as “Special”. This item includes the pipe specified by the plans and specifications, all fittings (including, but not limited to, bends, tees, reducers, plugs, and caps), tracing wire with test boxes (if required by specification), polyethylene wrap (when specified), labor, equipment, excavation, bedding, restoration, testing, sanitizing, backfill, and etc., required to install the specified new pipe and new fittings at the locations shown on the plans, or as directed, in accordance with the specifications and standard drawings complete and ready for use. No additional payment will be made for rock excavation. This bid item includes material and placement of flowable fill under existing and proposed pavement, and wherever else specified on the plans or in the specifications. **This item shall include all temporary and permanent materials and equipment required to pressure test and sanitize mains including, but not limited to, pressurization pumps, hoses, tubing, gauges, main taps, saddles, temporary main end caps or plugs and blocking, main end taps for flushing, chlorine liquids or tablets for sanitizing, water for testing/sanitizing and flushing (when not supplied by the utility), chlorine neutralization equipment and materials, and any other items needed to accomplish pressure testing and sanitizing the main installation.** This item shall also include pipe anchors, at each end of polyethylene pipe runs when specified to prevent the creep or contraction of the pipe. Measurement of quantities under this item shall be through fittings, encasements, and directional bores (only when a separate carrier pipe is specified within the directional bore pipe). Measurements shall be further defined to be to the center of tie-in where new pipe contacts existing pipe at the center of connecting fittings, to the outside face of vault or structure walls, or to the point of main termination at dead ends. No separate payment will be made under pipe items when the directional bore pipe is the carrier pipe. Please refer to the Utility Company’s Specifications. If the Company does not have specifications, KYTC’s Specifications shall be referenced. This item shall be paid LINEAR FEET (LF) when complete.

W PLUG EXISTING MAIN This item shall include the specified plug, concrete blocking and/or anchoring, labor, equipment, excavation, backfill, and restoration required to install the plug in an existing in-service main that is to remain at the location shown on the plans or as directed in accordance with the specifications. Any and all plugs on all existing in-service mains shall be paid under one bid item included in the contract regardless of size. No separate bid items will be established for size variations. Please refer to the Utility Company’s Specifications. If the Company does not have specifications, KYTC’s Specifications shall be referenced. This item shall be paid EACH (EA) when complete.

NOTE: This utility bid item is not to be paid on new main installations or abandoned mains. This pay item is to plug existing in-service mains only. Plugs on new mains are incidental to the new main just like all other fittings.

NOTE: Plugging of existing abandon mains shall be performed and paid in accordance with Section 708.03.05 of KYTC Standard Specifications For Road And Bridge Construction and paid using Bid Code 01314 Plug Pipe.

W PRESSURE REDUCING VALVE This description shall apply to all pressure reducing valves (PRV) of every size required in the plans and specifications except those bid items defined as “Special”. Payment under this description is to be for PRVs being installed with new main. This item includes the PRV as specified in the plans and specifications, polyethylene wrap (if required by specification), labor, equipment, excavation, anchoring (if any), pit or vault, backfill, restoration, testing, disinfection, and etc., required to install the specified PRV at the location shown on the plans in accordance with the specifications and standard drawings complete and ready for use. If required on plans and/or proposed adjoining DIP is restrained, PRVs shall be restrained. PRV restraint shall be considered incidental to the

PRV and adjoining pipe. Please refer to the Utility Company's Specifications. If the Company does not have specifications, KYTC's Specifications shall be referenced. This item shall be paid EACH (EA) when complete.

W PUMP STATION This item is for payment for installation of pumps and an above or below ground structure for housing of the pumps. This item shall include all pumps, piping, fittings, valves, electrical components, building materials, concrete, any other appurtenances, labor, equipment, excavation, and backfill, to complete the pump station installation as required by the plans, standard drawings, and specifications, complete and ready for use. Please refer to the Utility Company's Specifications. If the Company does not have specifications, KYTC's Specifications shall be referenced. This item shall be paid LUMP SUM (LS) when complete.

W REMOVE TRANSITE (AC) PIPE This item shall include all labor, equipment, and materials needed for removal and disposal of the pipe as hazardous material. All work shall be performed by trained and certified personnel in accordance with all environmental laws and regulations. Any and all transite AC pipe removed shall be paid under one bid item included in the contract regardless of size. No separate bid items will be established for size variations. Please refer to the Utility Company's Specifications. If the Company does not have specifications, KYTC's Specifications shall be referenced. This item shall be paid LINEAR FEET (LF) when complete.

W SERVICE LONG SIDE This bid item description shall apply to all service line installations of every size bid up to and including 2 inch inside diameter, except those service bid items defined as "Special". This item includes the specified piping material, main tap, tapping saddle (if required), and corporation stop materials, coupling for connecting the new piping to the surviving existing piping, encasement of 2 inches or less internal diameter (if required by plan or specification), labor, equipment, excavation, backfill, testing, disinfection, and restoration, at the locations shown on the plans or as directed, in accordance with the specifications and standard drawings, complete and ready for use. This bid item is to pay for service installations where the ends of the service connection are on opposite sides of the public roadway and the service line crosses the centerline of the public roadway as shown on the plans. The length of the service line is not to be specified. Payment under this item shall not be restricted by a minimum or maximum length. The contractor shall draw his own conclusions as to the length of piping that may be needed. Payment under this item shall include boring, jacking, or excavating across the public roadway for placement. Placement of a service across a private residential or commercial entrance alone shall not be reason to make payment under this item. Private or commercial entrances shall not be considered a public roadway in defining payment under this item. This pay item does not include installation or relocation of meters. Meters will be paid separately. No additional payment will be made for rock excavation or for special bedding required in rock excavation. Please refer to the Utility Company's Specifications. If the Company does not have specifications, KYTC's Specifications shall be referenced. This item shall be paid EACH (EA) when complete.

W SERVICE SHORT SIDE This bid item description shall apply to all service line installations of every size up to and including 2 inch internal diameter, except those service bid items defined as "Special". This item includes installation of the specified piping material of the size specified on plans, encasement of 2 inches or less internal diameter (if required by plan or specification), main tap, tapping saddle (if required), corporation stop, coupling for connecting the new piping to the surviving existing piping, labor, equipment, excavation, backfill, testing, disinfection, and restoration, at the locations shown on the plans or as directed, in accordance with the specifications and standard drawings, complete and

ready for use. This bid item is to pay for service installations where both ends of the service connection are on the same side of the public roadway, or when an existing service crossing a public roadway will remain and is being extended, reconnected, or relocated with all work on one side of the public roadway centerline as shown on the plans. The length of the service line is not to be specified and shall not be restricted to any minimum or maximum length. Payment shall be made under this item even if the service crosses a private residential or commercial entrance; but, not a public roadway. Private or commercial entrances shall not be considered a public roadway in defining payment under this item. The contractor shall draw his own conclusions as to the length of piping that may be needed. This pay item does not include installation or relocation of meters. Meters will be paid separately. No additional payment will be made for rock excavation or for bedding required in rock excavation. Please refer to the Utility Company's Specifications. If the Company does not have specifications, KYTC's Specifications shall be referenced. This item shall be paid EACH (EA) when complete.

W SERVICE RELOCATE This item is for the relocation of an existing water service line where a meter is not involved, and where an existing service line can easily be adjusted by excavating alongside and moving the line horizontally and/or vertically a short distance without cutting the service line to avoid conflicts with road construction. This item shall include excavation, labor, equipment, bedding, and backfill to relocate the line in accordance with the plans and specifications complete and ready for use. Payment under this item shall be for each location requiring relocation. Payment shall be made under this item regardless of service size or relocation length. No separate pay items will be established for size or length variation. Please refer to the Utility Company's Specifications. If the Company does not have specifications, KYTC's Specifications shall be referenced. This item shall be paid EACH (EA) when complete.

W STRUCTURE ABANDONMENT This item is to be used to pay for abandonment of larger above or below ground water structures such as meter vaults, fire pits, pump stations, tanks, and etc. Payment under this item shall not be limited to size or scope; however structures with connecting pipes of 2 inches or less shall not be paid under this item; but, shall be considered incidental to water construction, (i.e., abandonment of standard water meters up to and including 2 inches would not be paid under this item). Payment under this item shall include all labor, equipment, and compacted fill or flowable fill for abandonment of the structure in place and restoration complete. No separate bid items will be established for size or structure variations. Please refer to the Utility Company's Specifications. If the Company does not have specifications, KYTC's Specifications shall be referenced. This item shall be paid EACH (EA) when complete.

W STRUCTURE REMOVAL This item is to be used to pay for removal of larger above or below ground water structures such as meter vaults, fire pits, pump stations, tanks, and etc. Payment under this item shall not be limited to size or scope; however structures with connecting pipes of 2 inches or less shall not be paid under this item; but, shall be considered incidental to water construction, (i.e., removal of standard water meters up to and including 2 inches would not be paid under this item). Payment under this item shall include all labor, equipment, and compacted backfill for removal of the structure and restoration complete. No separate bid items will be established for size or structure variations. Please refer to the Utility Company's Specifications. If the Company does not have specifications, KYTC's Specifications shall be referenced. This item shall be paid EACH (EA) when complete.

W TAPPING SLEVE AND VALVE SIZE 1 OR 2 This item shall include the specified tapping sleeve, valve, valve box, concrete pad around valve box (when required in specifications or plans), labor, and equipment to install the specified tapping sleeve and valve, complete and ready for use in accordance with

the plans and specifications. The size shall be the measured internal diameter of the live pipe to be tapped. The size tapping sleeve and valve to be paid under sizes 1 or 2 shall be as follows:

Size 1 = All live tapped main sizes up to and including 8 inches

Size 2 = All live tapped main sizes greater than 8 inches

Please refer to the Utility Company's Specifications. If the Company does not have specifications, KYTC's Specifications shall be referenced. This item shall be paid EACH (EA) when complete.

W TIE-IN This bid description shall be used for all main tie-in bid items of every size except those defined as "Special". This item includes all labor, equipment, excavation, fittings, sleeves, reducers, couplings, blocking, anchoring, restoration, disinfection, testing and backfill required to make the water main tie-in as shown on the plans, and in accordance with the specifications complete and ready for use. Pipe for tie-ins shall be paid under separate bid items. This item shall be paid EACH (EA) when complete.

W VALVE This description shall apply to all valves of every size required in the plans and specifications except those bid items defined as "Special". Payment under this description is to be for gate or butterfly valves being installed with new main. This item includes the valve as specified in the plans and specifications, polyethylene wrap (if required by specification), labor, equipment, excavation, anchoring (if any), valve box and valve stem extensions, backfill, concrete pad around valve box (if required by specification), restoration, testing, disinfection, and etc., required to install the specified valve at the location shown on the plans in accordance with the specifications and standard drawings complete and ready for use. If required on plans and/or proposed adjoining DIP is restrained, valves shall be restrained. Valve restraint shall be considered incidental to the valve and adjoining pipe. This description does not apply to cut-in valves. Please refer to the Utility Company's Specifications. If the Company does not have specifications, KYTC's Specifications shall be referenced. This item shall be paid EACH (EA) when complete.

W VALVE ANCHOR EXISTING This bid item is intended to pay for installation of restraint hardware on an existing valve where no restraint exists to hold the valve in place to facilitate tie-ins and other procedures where restraint is prudent. This work shall be performed in accordance with water specifications and plans. This bid item shall include all labor equipment, excavation, materials and backfill to complete restraint of the designated valve, regardless of size, at the location shown on the plans, complete and ready for use. Materials to be provided may include, but is not limited to, retainer glands, lugs, threaded rod, concrete, reinforcing steel or any other material needed to complete the restraint. Should the associated valve box require removal to complete the restraint, the contractor shall reinstall the existing valve box, the cost of which shall be considered incidental to this bid item. No separate bid items are being provided for size variations. All sizes shall be paid under one bid item. Please refer to the Utility Company's Specifications. If the Company does not have specifications, KYTC's Specifications shall be referenced. This item shall be paid EACH (EA) when complete.

W VALVE BOX ADJUST Includes all labor, equipment, valve box and valve stem extensions (if required), excavation, backfill, concrete pad around valve box (when specified in specifications or plans), restoration, and etc., to adjust the top of the box to finished grade complete and ready for use. Please refer to the Utility Company's Specifications. If the Company does not have specifications, KYTC's Specifications shall be referenced. This item shall be paid EACH (EA) when complete.

W VALVE CUT-IN This bid description is for new cut-in valve installations of all sizes where installation is accomplished by cutting out a section of existing main. This item shall include cutting the existing pipe, supplying the specified valve, couplings or sleeves, valve box, concrete pad around valve box (when required in specifications or plans), labor, equipment, and materials to install the valve at the locations shown on the plans, or as directed by the engineer, complete and ready for use. Any pipe required for installation shall be cut from that pipe removed or supplied new by the contractor. No separate payment will be made for pipe required for cut-in valve installation. Please refer to the Utility Company's Specifications. If the Company does not have specifications, KYTC's Specifications shall be referenced. This item shall be paid EACH (EA) when complete.

W VALVE VAULT This item is for payment for installation of an underground structure for housing of specific valve(s) as required by the plans and specifications. This item shall include all labor, equipment, excavation, concrete, manhole castings or doors, the specified valve(s), all piping, and fitting materials associated with installing a functioning valve vault in accordance with the plans, standard drawing, and specifications, complete and ready for use. Please refer to the Utility Company's Specifications. If the Company does not have specifications, KYTC's Specifications shall be referenced. This item shall be paid EACH (EA) when complete.

TECHNICAL SPECIFICATIONS

LAUREL COUNTY WATER DISTRICT No. 2
LAUREL COUNTY, KENTUCKY

U.S. 25 E CUMBERLAND GAP PARKWAY
WATER SYSTEM RELOCATION – PHASE II-B

PROJECT No. 1822

SEPTEMBER 2019

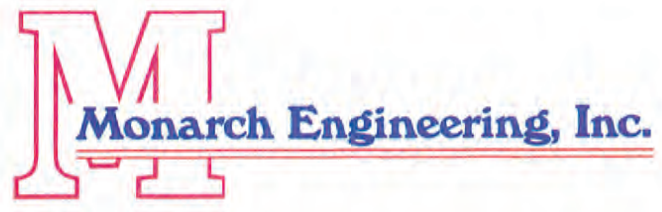

TABLE OF CONTENTS

SECTION 1 - WATER MAINS	Section 1-1
SECTION 2 - CASING PIPE	Section 2-1
SECTION 3 - CREEK CROSSING.....	Section 3-1
SECTION 4 - VALVE AND VALVE BOX	Section 4-1
SECTION 5 - FLUSH HYDRANT	Section 5-1
SECTION 6 - BLOWOFF ASSEMBLY	Section 6-1
SECTION 7 - CONNECTION.....	Section 7-1
SECTION 8 - AIR RELEASE VALVE.....	Section 8-1
SECTION 9 - DIRECTIONAL DRILLING / BORING.....	Section 9-1
SECTION 10 - METTER SETTING & RECONNECTION.....	Section 10-1
SECTION 11 - STONE AGGREGATE	Section 11-1
SECTION 12 - PAVEMENT REPLACEMENT.....	Section 12-1
SECTION 13 - EXPLORATION	Section 13-1
TOPOGRAPHIC MAP	TM-1

SECTION 1 - WATER MAINS

1.0 Work Included. Under this item the Contractor shall provide all labor, tools, equipment, and materials to furnish and install the water mains as shown on the drawings and as directed

1.1 Water Pipe Materials. All pipe materials shall conform to the manufacturer's standard lengths and diameters. Testing when required by the Owner shall be done in accordance with the appropriate ASTM specifications for the material selected. The water main type shall be PVC water pipe or ductile iron.

1.1.1 Polyvinyl Chloride Pipe PVC SDR 17 or SDR 21. PVC pipe shall comply with ASTM D-1784 for material and shall be Class 250 (SDR 17) or Class 200 (SDR 21) as shown on the drawings or indicated on the bid form. All PVC pipe shall conform to the latest revisions of the following specifications:

ASTM D2241 (PVC Plastic Pipe SDR-PR and Class T)
National Sanitation Foundations Testing Laboratories (NSF)

The name of the manufacturer of the plastic pipe to be used must be found on the current listing of Plastic Materials for Potable Water Application, published by the NSF (National Sanitation Foundation), and must meet the requirements of the Standard Specification for Polyvinyl Chloride (PVC) Plastic Pipe, D1784, 12454-B (PVC 1120) published by ASTM. Rubber gaskets shall conform to ASTM D3139.

Wall thickness shall be in accordance with ASTM D-2241. Pipe ends shall be beveled to accept the coupling with gasket. The bell section shall be designed to be as strong as the pipe wall.

Samples of pipe physical and chemical data sheets shall be submitted to the Engineer for approval prior to the pipe being purchased.

The pipe shall be homogeneous throughout and free from cracks, holes, foreign inclusions, or other defects. The pipe shall be as uniform as commercially practical in color and shall have a ring painted around the spigot ends in such a manner as to allow field checking of setting depth of the pipe in the socket. Pipe must be delivered to the job site by means that will adequately support it and not subject it to undue stresses. In particular, the load shall be so supported such that the bottom rows of pipe are not damaged by crushing. The pipe shall be unloaded carefully and stored as close to the final point of placement as is practical.

Pipe markings shall include the following marked continuously down the length:

- Manufacturer's Name
- Nominal Size
- Class Pressure Rating
- PVC 1120
- NSF Logo
- Identification Code

The lubricant shall be that as recommended and supplied by the pipe manufacturer.

1.1.2 Polyvinyl Chloride Pipe (PVC) Cast Iron Pipe Size. This pipe shall meet the requirements of AWWA C900-75, latest revision, "Standard for Polyvinyl Chloride (PVC) Pressure Pipe, 4 inch through 12 inch for Water" and shall be furnished in cast iron pipe equivalent outside diameters with separate couplings including gaskets.

The pipe shall be made from Class 12454-A or Class 12454-B virgin compounds as defined in ASTM D-1784. The standard code designation shall be PVC 1120. The PVC compounds shall be tested and certified as suitable for potable water products by the NSF approval marking.

Solvent cement couplings or joints shall not be used. PVC joints using elastomeric gaskets shall be tested as assembled joints and shall meet the laboratory performance requirements specified in ASTM D-3139.

Pipe shall be pressure Class 200, DR 14 or Class 150, DR 18 as shown on the drawings or the bid form.

Pipe and Couplings shall be marked as follows:

- Nominal Size and OD Base
- Material Code Designation (PVC 1120)
- Dimension Ratio Number
- AWWA Pressure Class
- AWWA Designation Number (AWWA C900)
- Manufacturers Name or Trade Mark and Production Record Code
- Seal of the NSF Laboratory

Each standard and random length of pipe shall be proof tested at four times its rated class pressure for a minimum of 5 seconds. Bells or couplings shall be tested with the pipe.

The pipe shall not split, crack, or break when tested by the parallel plato method, and it shall not flake or disintegrate when tested by the acetone immersion method as specified by ASTM D-2241.

1.1.3 Ductile Iron Pipe. Ductile Iron Pipe shall be designed in accordance with AWWA (ASA A21.50) and for the conditions as stated in these specifications and the pressure rating for the pipe shall be 350 PSI. Ductile iron pipe shall conform to AWWA C-151 (ASA A21.51). Pipe shall be cement lined in accordance with AWWA C104 (ASA A21.4) and all exposed pipe and fittings shall have a shop prime coat applied that is compatible with subsequent field enamel paint coats.

The specified thickness will be determined for the given internal and external loading requirements in accordance with ASA A21.50 and will be shown on the drawings or the bid form. The net weight, class or nominal thickness and sampling period shall be marked on each pipe.

Pipe joints shall be mechanical joint, rubber ring slip joint, flanged, or locked mechanical joint equal to AWWA C-111.

1.1.4 Fittings. Ductile Iron mechanical joint fittings with appropriate adapters shall be used with PVC pipe and ductile iron pipe. Fittings shall comply with AWWA C-110 or C-111 and shall be manufactured for the size and pressure class of the line on which they are used. Compact fittings are acceptable and they shall conform to the latest AWWA specifications.

Mechanical joint fittings shall be used with ductile iron pipe for below ground burial and flange fittings shall be used for all interior piping where ductile iron pipe is used.

1.1.5 Mechanical Joint Restraints. Restraint devices for mechanical joint fittings shall be utilized with all fittings on both Ductile Iron and PVC pipe. Restraints shall conform to either ANSI/AWWA C111/A21.11 or ANSI/AWWA C153/A2153 and shall be manufactured for size and pressure class of the line on which they are used. Restraint devices for nominal pipe sizes 3-inch through 36-inch shall consist of multiple gripping wedges incorporated into a follower gland meeting the applicable requirements of ANSI/AWWA C110/A21.10. All Mechanical joint restraints shall be the MEGALUG® Restraint Series 2000 as manufactured by EBAA Iron, Inc., or approved equal.

1.2 Pipe Handling. Pipe delivered to the site shall be stored, handled, distributed, placed, joined together, etc. in accordance with the manufacturer's recommendation unless directed otherwise by the Engineer.

1.3 Water Main Location. The water main shall be installed in the locations as shown on the drawings or as otherwise directed in the field by the Engineer.

The contractor, at his expense, shall acquire the services of a Licensed Profession Land Surveyor (Surveyor) to stake the horizontal location of all proposed water lines and appurtenances. For those points where the vertical location (elevation) of the proposed water lines and appurtenances is deemed critical and is specifically noted on the plans, the Surveyor shall include this information as part of the staking operations and thereafter confirm that that installed elevation is correct. The Engineer, in association with the

KYTC Department of Highways, will supply the Surveyor with horizontal and vertical control points as required.

During construction, the Contractor and Engineer shall agree as to the exact location of the water line and there shall be no disputes unless it is clear that the proposed location significantly deviates from the drawings. At those locations where the drawings indicate that a fitting must be installed either by declaration on the drawings or by a defined bend as shown on the drawings, the Contractor shall do so and shall avoid over deflection of the pipe.

1.4 Excavation. The Contractor shall make trench excavations to only such width to provide ample room for proper construction. Sheeting and shoring shall be provided as required for proper safety and compliance with OSHA regulations. Rock excavation shall be taken to a depth of 6 inches below the bottom of the pipe. If poor foundation conditions exist due to unstable subsurface conditions, the trench shall be under excavated to the depth required and filled with stone to obtain proper bearing capacity.

Watchmen or barricades, lanterns, and other such signs and signals as is necessary to warn the public of the dangers in connection with open trenches, excavations and other obstructions shall be provided by and properly maintained at the expense of the Contractor.

Only one half of street crossings and road crossings shall be excavated before placing temporary bridges over the excavation.

1.5 Blasting and Rock Excavation. The Contractor shall make his own investigation as he deems necessary to ascertain the sub surface conditions to be encountered in the work.

All blasting operations shall be conducted in accordance with municipal ordinances, state and federal laws and the applicable blasting codes. Soil particle velocity shall not exceed the limit set by Kentucky law. All explosives shall be stored in conformity with the applicable ordinances, laws and safety regulations. No blasting shall be done within five feet of any water mains, sewer lines, natural or manufactured gas lines, liquid petroleum lines, or other utilities.

The Contractor shall use delay caps or other approved methods to reduce earth vibrations and noise. Mud capping shall not be permitted as a method to breaking boulders. No blasting shall be permitted on Sundays or after dark.

Prior to commencing with the work, the Contractor shall, during a preconstruction conference with the Owner and Engineer, state clearly his approach to performing the excavations on the project. He shall be familiar with the laws and ordinances covering blasting and shall also give consideration to the use of hydraulically operated rock breaking devices in lieu of blasting where considered necessary. If blasting is not handled in an expert manner at all times the Engineer reserves the right to suspend blasting and require the work to proceed without it. Prior to blasting, the Contractor shall make his own detailed preblast survey of adjacent walks, curbs, retaining walls, house foundations, etc. to determine conditions prior to the work. Such a file of information, including

photographs, may be certified in such a manner as the Contractor believes necessary. This information if required or performed shall be supplied to the Engineer prior to performing the work.

1.6 Storage of Excavated Material. All excavated material shall be stored in a manner that will not endanger the work and that will avoid obstructing roadways, sidewalks, and driveways. Hydrants under pressure, valve pit covers, valve boxes, curb stop boxes, fire and police call boxes, or other utility controls shall be left unobstructed and accessible. Gutters shall be kept clear or other satisfactory provisions made for street drainage, and natural watercourses shall not be obstructed.

1.7 Shoring Sheeting and Bracing. The Contractor shall furnish place and maintain such sheeting and bracing as may be required to support the sides of the excavation or to protect other structures from possible damage. All sheeting and bracing shall be removed upon completion of the work unless permitted to be left in place by the Engineer. Any sheeting or bracing left in place shall be cut off at least two feet below the finished ground surface elevation. The cost of furnishing, placing, maintaining, and removing sheeting and bracing shall be included in the unit price bid for water lines and all work shall conform the OSHA requirements.

1.8 Bedding and Backfill. All water mains shall be bedded with select earth backfill or six inches of #9 or approved equal stone under and on both sides of the pipe where it is installed along the unpaved areas. Where the water line is installed along the paved areas the water line shall be backfilled with #9 or approved equal stone. Trenches shall be backfilled immediately after the water main has been installed. No rock larger than two inches will be permitted within six inches of the pipe. In unpaved or unsurfaced areas the remainder of the fill may be mounded over the top of the trench. Where trenches are in paved or traveled areas, or yard areas, compaction shall be performed during backfill. The Contractor at no time shall open up more than 500 feet of trench.

Any damage to underground structures, pipes, wires, drains, etc., shall not be backfilled until they have been satisfactorily repaired or replaced to the original serviceability at the Contractor's expense and as approved by the Engineer. Settlement of backfill may be done with water furnished by the Contractor under the direction of the Engineer where such will not endanger traffic or damage property. When excavated rock is used for backfilling, it shall have sufficient dirt or fine material to fill all voids and shall not be used within twelve inches of the pipe.

To be accepted as final cleanup all excess rock one inch and larger shall be removed from the disturbed area.

1.9 Thrust Blocks and Anchorage. Thrust blocks shall be installed at all tees, bends, crosses, dead ends, valves, hydrants, blowoff assemblies, and as directed by the Engineer. The size of the thrust block shall depend on the soil and type of fitting, and shall conform to the pipe manufacturer's recommendations. At any location where a vertical bend is

required the Contractor shall install the anchorage as directed by the Engineer in conjunction with the pipe manufacturer.

Thrust blocks shall be constructed of Class B concrete conforming to KBH Specification 601 and placed between the fitting and the trench wall. At no time will sack-crete or pre bagged concrete mixtures be allowed. All thrust block and anchorage concrete shall be delivered to the job site by means of a ready mix concrete truck and placed immediately upon arrival.

The thrust blocks shall be sized as shown on the detail drawings or as directed by the Engineer.

1.10 Temporary Surfacing. All trenches in paved areas shall, following compacted backfill, receive a top layer of compacted dense grade stone as shown on the detailed drawings. Such temporary surfacing shall be maintained and shall be paved as soon as conditions permit.

1.11 Hydrostatic Testing. The water line and appurtenances, as rapidly as valves are installed, shall be hydrostatically tested in accordance with these specifications. Defective joints of pipe shall be replaced as directed by the Engineer. Cracked or defective pipe, fittings, valves, or hydrants shall be replaced by the Contractor and the test shall be repeated until the test results are satisfied. All meter settings and service tubing as shown on the drawings shall be included in the hydrostatic test.

The test pressure shall not be less than 1.25 times the working pressure at the highest point along the test section and the hydrostatic test shall be of at least a two hour duration. The test pressure shall not vary by more that five psi. for the duration of the test.

1.11.1 Pressurization. After the pipe has been installed all or any valved section shall be subjected to the hydrostatic test. Each valved section of the pipe shall be slowly filled with water and the specified test pressure, corrected to the elevation of the test gauge, shall be applied by means of a pump connected to the pipe in a manner satisfactory to the Engineer. As part of the testing equipment a meter shall be installed to measure all water added to the tested section.

1.11.2 Air Removal. Before applying the specified test pressure, air shall be expelled completely from the pipe, valves, and hydrants. If permanent air vents are not located at all high points, the Contractor shall install corporation cocks at such points so that the air can be expelled as the line is filled with water. After all the air has been expelled, the corporation cocks shall be closed and the test pressure applied. At the conclusion of the pressure test, the corporation cocks shall be removed and plugged or left in place at the discretion of the Owner.

1.11.3 Leakage Defined. Leakage shall be defined as the quantity of water that must be supplied into the newly laid pipe or any valved section thereof to maintain pressure within five psi. of the specified test pressure after the pipe has been filled with water and the air has been expelled. Leakage shall not be measured by a drop in pressure in a test section over a period of time.

1.11.4 Allowable Leakage. No pipe installation will be accepted if the leakage is greater than that determined by the following formula:

$$L = \frac{SD\sqrt{P}}{133,200}$$

Where:

L = allowable leakage in gallons per hour

S = length of pipe tested in feet

D = nominal diameter of the pipe in inches

P = average test pressure during the leakage test in pounds per square inch

This formula is based on an allowable leakage of 11.65 gpd./mi./in. of nominal diameter at a pressure of 150 psi.

All leaks shall be repaired whenever or wherever there is evidence of a leak. Water lost by the Contractor shall be paid for by the Contractor at the rate of \$2.00 per 1,000 gallons.

1.12 Sterilization. Upon completion and acceptance of the hydrostatic test of a section of the water main that section shall be thoroughly disinfected before being placed in service by the use of chlorine or chlorine compounds in such amounts as to produce a concentration of not less than 50 ppm and a residual of not less than 25 ppm at the end of 24 hours and followed by thorough flushing. Putting small amounts of chlorine in each joint will not be acceptable.

Where shown on the plans or otherwise required, temporary blowoff assemblies shall be constructed by the contractor to facilitate the sterilization & flushing of new water mains. The temporary blowoff assemblies shall consist of valves, PVC piping, and ductile iron fittings and other materials as depicted in the standard drawings. The installation and subsequent removal of these temporary devices shall be considered incidental to the installation of the water lines and no additional payment or bid item will be included for them.

1.13 Other Utilities. Other utilities encountered in the work shall be preserved and protected. Where relocation or repair is required to accommodate the work it shall be made in a manner acceptable to the utility having jurisdiction over the service connection. Accommodation of service connections shall not constitute any basis for extra payment.

Prior to construction, the Contractor shall arrange to meet with representatives of all utilities, and provide them with his anticipated work schedule. The Contractor shall have the utility companies make their best determination of utility locations in the areas in which he is working. Throughout the progress of the work such field markings of utilities shall be kept current.

1.14 Payment for Water. All water used from the Owner shall be metered by meters supplied by the Contractor. The Contractor shall pay for such water at the rate of \$2.00 per 1,000 gallons. This shall include any unmetered water lost which shall be computed on the basis of a discharge velocity of seven feet per second, the diameter of the line, and the estimated duration of free uncontrolled discharge or the approved method.

1.15 Cleanup. The Contractor shall provide effective cleanup of the work as it progresses. At the time of final inspection no trenches shall show any undue evidence of the construction. All areas shall be left free of ruts due to construction and shall have a clean and neat appearance without rubble or debris. The areas shall not be mounded and shall be completely restored, and all yards and fields shall be reseeded. Straw and fertilizing shall accompany the seeding and the seed mixture shall match the existing ground cover. If necessary to hasten proper restoration of terraces, principally along ditch lines, the Contractor shall sod such areas at the Engineer's direction.

1.16 Protection of Adjacent Landscape. Reasonable care shall be taken during construction of the process lines to avoid damage to vegetation. Ornamental shrubbery and tree branches shall be temporarily tied back, where appropriate, to minimize damage. Trees which receive damage to branches shall be trimmed of those branches. Tree trunks receiving damage from equipment shall be treated with a tree dressing.

1.17 Underground Detection Wire. At all locations where water lines are installed, a detection wire shall be installed. For open cut installation, tracer wire is to be #12 AWG solid copper with 30 mil blue HDPE insulation. For trenchless installation, tracer wire is to be #12 AWG solid copper clad steel core with 45 mil blue HDPE insulation. Direct bury wire connectors which are prefilled with dielectric silicone sealant and equipped with an integral strain relief cap shall be used at all splice joints. The wire connectors shall be DryConn DBSR Aqua as manufactured by King Innovation or approved equal.

Tracer wire shall be installed with the pipe at the trench bottom and access boxes shall be installed at each valve, hydrant and air release valve. Tracer wire access boxes shall be spaced no further than 1000' apart. A minimum of 3 feet of tracer wire should be coiled up inside of each access box. Tracer wire access boxes shall be magnetized heavy duty type as manufactured by Copperhead Industries, LLC, Snake Pit or approved equal.

Prior to the time of the final inspection, the Contractor shall perform a continuity test of the underground detection wire system to ensure continuity and proper operation. This test shall be witnessed by the Engineer or the Owner.

1.18 Exposing Existing Water Line. Where the new water line is to be installed parallel to an existing water line the Contractor shall be responsible for exposing the existing water lines at 100 feet intervals prior to installation of new water line. This work shall be considered incidental to the installation of the water lines and no additional payment or bid item will be provided.

1.19 Payment. Payment shall be included in the payment for the work to which it is subsidiary in the Bid Schedule.

SECTION 2 - CASING PIPE

2.0 Work Included. Under this item the Contractor shall provide all labor, tools, equipment, and materials to furnish and install casing pipes as shown on the drawings.

2.1 Materials. Bored and jacked casing pipe shall be plain end steel pipe conforming to AWWA Specification C200 with a minimum yield strength of 35,000 psi. The inside diameter of the casing pipe shall be a minimum of four inches greater than the largest outside diameter of the water pipe, joint or coupling.

The minimum wall thickness shall be in accordance with the following table:

Diameter of Casing-Inches	Minimum Wall Thickness-Inches	
	<u>Under Railroads</u>	<u>All Other Uses</u>
12-3/4 and under	0.250	0.188
14	0.250	0.250
16	0.281	0.250
18	0.312	0.250
20 and 22	0.344	0.250

Casing pipe shall have continuously welded joints. Any field welding shall be performed by a certified welder and shall be in accordance with AWWA Specifications C206

2.2 Prior Approvals. Prior to boring and jacking under roadways the Contractor shall submit drawings and other necessary information regarding the proposed construction to the Engineer for approval by the proper authorities if requested.

2.3 Bore and Jack Construction. The Contractor shall investigate the subsurface conditions which will be encountered and shall base his bid on his findings. No distinction shall be made between boring through earth and boring through rock.

The Contractor shall provide a jacking pit, bore through the earth and or rock, and jack the casing pipe into place at the proper line and grade as the bore is being made. "Free boring" will not be allowed unless specifically directed by the Engineer.

The approach trench shall be large enough to accommodate one section of casing pipe and the jacks and blocking. Two rails or sills shall be laid in the bottom of the trench to keep the casing at the established line and grade.

The installation procedure must be such that the casing pipe is placed concurrently with the removal of the soil. The outside diameter of the lead auger section must not be less than one half inch smaller in diameter than the casing inside diameter.

The carrier pipe shall be pushed through the casing pipe with care being taken to insure that the pipe joints are tight and properly made. Casing spacers shall be attached to the carrier pipe to prevent floating shall be used and shall be appropriate for the type of carrier pipe being used. Casing spacers shall be used regardless of the type of casing piping being used.

The ends of the casing pipe shall be plugged and made watertight prior to backfilling. A neoprene gasket that will slip over the cover pipe and allow the carrier pipe to pass through will be considered water tight.

2.4 Open Cut Construction. Where casing pipe is to be installed by open cutting rather than by boring or jacking, the same materials and methods as described above will be utilized.

2.5 Traffic Control Devices and Maintenance of Traffic. The proper placement and maintenance of traffic control devices and the maintenance of traffic flows shall comply with the standards set forth under the General Specifications.

The Contractor shall notify the proper City, County, or State officials prior to the commencement of boring and jacking or tunnel operations.

2.6 Measurement and Payment. The unit price bid per linear foot for boring and jacking, as measured from end to end of the casing pipe, shall constitute full compensation for the work as specified. Open cut steel casing pipe as measured from end to end of the casing pipe shall constitute full compensation for the work as specified. Carrier pipes shall be furnished under the item as described in other portions of these technical specifications.

SECTION 3 - CREEK CROSSING

3.0 Work Included. Under this item the Contractor shall provide all labor, tools, equipment, and materials to install creek crossings as shown on the drawings and as directed.

3.1 Materials. The creek crossing shall be installed as per the detailed drawings or as described herein and the casing pipe shall be PVC SDR-35 pipe. In the event where a casing pipe is not required the creek crossing shall be installed with ductile iron. All carrier pipe and casing pipe shall be that as described in other sections of these technical specifications or as shown on the plan sheets

3.2 Installation. The creek crossings shall be installed with plastic carrier pipe placed within a plastic casing pipe, or ductile iron carrier pipe without a casing pipe unless specified otherwise. Where a plastic casing pipe is used it shall be of the minimum size to accommodate the carrier pipe.

Where a casing pipe is used, casing spacers shall be attached to the carrier pipe to prevent floating shall be used and shall be appropriate for the type of carrier pipe being used. Casing spacers shall be used regardless of the type of casing piping being used. The ends of the casing pipe shall be plugged and made watertight prior to backfilling. A neoprene gasket that will slip over the cover pipe and allow the carrier pipe to pass through will be considered water tight.

The casing pipe or water line pipe without casing pipe shall be placed a minimum of 30 inches below the bed of the stream, creek, or river and a twelve inch minimum layer of crushed stone shall be placed above the pipe where a casing pipe is not required. Class B concrete shall be placed between the crushed stone and the base of the stream, creek, or river, or between the casing pipe and the base of the waterway. Where concrete is placed, all water from the stream shall be diverted away from the area of concrete placement by means of diversion pipes or temporary embankments.

3.3 Payment. The unit bid shall constitute full compensation for furnishing and installing the creek crossings.

SECTION 4 – VALVE AND VALVE BOX

4.0 Work Included. Under this item the Contractor shall provide all labor, tools, equipment, and materials to install gate valve and valve boxes at the locations as shown on the drawings and as directed.

4.1 Materials. All gate valves shall be resilient wedge seat gate valves which fully comply with the latest revision of AWWA C509, and shall also be UL listed and FM approved. The valves shall be tested and certified to ANSI/NSF 61. The valves shall have a 250 psig working pressure. The valve type shall be NRS (non-rising stem) and the valve shall have an arrow cast on the 2” square operating nut which shows the opening direction. The direction of opening shall be shall to the left. The bolt that attaches the operating nut to the stem shall be recessed into the operating nut so as not to interfere with valve wrench operation.

The valves shall have bolts and nuts for the stuffing box and bonnet with one of the following compositions:

- a. Steel, ASTM A-307, Grade B zinc plated.
- b. Type 304 stainless steel.
- c. Type 316 stainless steel.

Valve stems shall be made of bronze ASTM B-132 alloy C67600 bar stock material. The stem shall have at least one “anti-friction” thrust washer above and below the stem collar to reduce operating torque. The design of the valve stem shall be such that if excessive input torque is applied, stem failure shall occur above the stuffing box at such a point as to enable the operation of the valve with a pipe wrench or other readily available tool. The stem material shall provide a minimum 70,000 psi tensile strength with 15% elongation and yield strength of 30,000 psi. Valves with cast stems or two piece stem collars are not acceptable.

The valves shall have a stuffing box that is o-ring sealed. Two o-rings shall be placed above and one o-ring below the stem thrust collar. The thrust collar shall be factory lubricated. The thrust collar and its lubrication shall be isolated by the o-rings from the waterway and from outside contamination providing permanent lubrication for long term ease of operation. Valves without a stuffing box are unacceptable. Valves without at least three stem o-rings are also unacceptable. The valve body, bonnet, stuffing box, and disc shall be composed of ASTM A-126 Class B grey iron or ASTM A395 or A536 ductile iron. The body and bonnet shall also adhere to the minimum wall thickness as set forth in Table 2, section 4.3.1 of AWWA C509.

The valve disc and guide lugs must be fully (100%) encapsulated in SBR ASTM D2000 rubber material. The peel strength shall not be less than 75 pounds per inch. Guide caps of an acetal bearing material shall be placed over solid guide lugs to prevent abrasion and to reduce the operating torque.

The valves shall have all internal and external ferrous surfaces coated with a fusion bonded thermosetting powder epoxy coating of 10 mils nominal thickness. The coating shall conform to AWWA C550.

Tapping valves shall have an inlet flange conforming to ANSI B16.1 Class 125 for attachment to a tapping sleeve or cross. In addition, the valve inlet flange shall have a machined projection or raised face complying with MSS SP-60 for accurate alignment to the mating recess in the tapping sleeve flange. The seat opening of the tapping valves shall be at least .30" larger than the nominal pipe size to permit full diameter cuts.

The valves shall be warranted by the manufacturer against defects in materials or workmanship for a period of ten (10) years from the date of manufacture. The manufacturing facility for the valves must have current ISO certification.

Each valve shall have the manufacturer's initials, pressure rating, and the year in which manufactured, cast onto the body.

The manufacturer shall be Mueller Co. or approved equal

Valve boxes shall be of cast iron extension type with screw adjustments and flared base. The minimum thickness of metal shall be 3/16". The cover shall have the word "WATER" cast in the metal. Valve boxes shall be installed over each outside gate valve unless otherwise shown on the drawings. The boxes shall be of such length as to provide a depth of cover of not less than 30 inches over the pipe.

4.2 Installation. Valve boxes shall be set plumb and straight and with the operating nut directly in the center in thoroughly compacted earth with the top of the box level and projecting one fourth inch above paved streets and one inch above other areas. The valve boxes in unpaved areas shall have a four inch thick concrete slab three feet in diameter around and sloping away from the valve box.

A valve operator extension shaft (stem extension) equal to that manufactured by Trumbull Industries, Inc., shall be installed for any valves with their operating nut 36 inches or more below the top of the valve box.

Where gate valves are shown directly adjacent to a tee or other fitting, the valve shall be connected directly to the fitting using Foster or Flex adapters by InFact Corporation.

Where applicable, the contractor is also responsible under this bid item for the abandonment of existing valves located on water lines to be de-commissioned as part of this project. This includes removing all remnants of the valve box and all other related appurtenances to a point two feet below existing ground level. Any void created by removal of items shall be backfilled with the adjacent area being restored to match the surrounding ground conditions including any incidental pavement replacement which may be required.

4.3 Payment. The unit price bid shall constitute full compensation for furnishing and installing gate valves, isolation valves, valve boxes, and other related appurtenances.

SECTION 5 – FLUSH HYDRANT

5.0 Work Included. Under this item the Contractor shall provide all labor, tools, equipment, and materials to install the hydrants as shown on the drawings and as directed by the Engineer.

5.1 Materials. Hydrants shall meet or exceed all applicable requirements and tests of ANSI and the latest revisions of AWWA Standard C502. They shall also meet all test requirements and be listed by Underwriters Laboratories Inc. They shall also meet all test requirements and have full approval of Factory Mutual. Hydrants shall be of the compression type, opening against the pressure and closing with the pressure and shall be rated for a minimum working pressure of 250 psi. They shall have a minimum 4-1/2" main valve opening and a minimum inside lower/upper barrel diameter (I.D.) of 6" to assure maximum flow performance. All hydrants shall be three-way in design, having one 4-1/2" pumper nozzle and two 2-1/2" hose nozzle(s). Nozzles shall thread counterclockwise into hydrant barrel utilizing "o" ring seals. A suitable nozzle lock shall be in place to prevent inadvertent nozzle removal.

The hydrant bonnet shall be attached to the upper barrel by not less than eight bolts and nuts and sealed by an "o" ring. The bonnet assembly shall provide an oil reservoir and lubrication system that automatically circulates lubricant to all stem threads and bearing surfaces each time the hydrant is operated. This lubrication system shall be sealed from the waterway and any external contaminants by use of "o" ring seals. An anti-friction washer shall be in place above the thrust collar to further minimize operating torque. The oil reservoir shall be factory filled with a low viscosity, FDA approved non-toxic oil lubricant which will remain fluid through a temperature range of -60⁰ F. to +150⁰ F.

The operating nut shall be a one piece design, pentagon/square in shape manufactured of ASTM B-584 bronze. The operating nut shall be affixed to the bonnet by means of an ASTM B-584 bronze hold down nut. The hold down nut shall be threaded into the bonnet in such a manner as to prevent accidental disengagement during the opening cycle of the hydrant. The use of Allen head set screws as a means of retention is unacceptable. A resilient weather seal shall be incorporated into the hold down nut, for the purpose of protecting the operating mechanism from the elements. The direction of the opening shall be as specified by the counterclockwise. An arrow shall be cast on the bonnet flange to indicate the opening direction.

Hydrants shall be a "traffic-model" having upper and lower barrels joined at the ground line by a separate and breakable "swivel" flange providing 360° rotation of upper barrel for proper nozzle facing. This flange shall employ not less than eight bolts. The safety flange segments shall be located under the upper barrel flange to prevent the segments from falling into the lower barrel when the hydrant is struck. The pressure seal between the barrels shall be an "o" ring. The proper ground line shall be cast clearly on the lower

barrel and shall provide not less than 18" of clearance from the centerline of the lowest nozzle to the ground.

The operating stem shall consist of two pieces, not less than 1 1/4" diameter (excluding threaded or machined areas) and shall be connected by a stainless steel safety coupling. The safety coupling shall have an integral internal stop to prevent the coupling from sliding down into the lower barrel when the hydrant is struck. Screws, pins, bolts, or fasteners used in conjunction with the stem couplings shall also be stainless steel. The top of the lower stem shall be recessed 2" below the face of the safety flange to prevent water hammer in the event of a "drive over" where a vehicle tire might accidentally depress the main valve. The lower barrel shall be an integrally cast unit. The use of threaded on or mechanically attached flanges is deemed unacceptable. The hydrant bury depth shall be clearly marked on the hydrant lower barrel.

Composition of the main valve shall be a molded rubber having a durometer hardness of 95 +/- 5 and shall be reversible in design to provide a spare in place. Plastic (polyurethane) main valves are unacceptable. The main valve shall have a cross section not less than 1".

Hydrants shall be equipped with (2) two drain valves which drain the barrel when the hydrant is closed and seal shut when the hydrant is opened. These drain valves shall be an integral part of the one piece bronze upper valve plate. They shall operate without the use of springs, toggles, tubes, levers or other intricate synchronizing mechanisms. The upper valve plate, seat ring and drain ring (shoe bushing) must be ASTM B-584 bronze and work in conjunction to form an all bronze drain way. A minimum of two (2) internal and two (2) external drain openings are required. Drains ported through an iron shoe must be bronze lined. The bronze seat ring shall thread into a bronze drain ring (or shoe bushing) providing a bronze to bronze connection. Seat rings shall be "o" ring pressure sealed

The interior of the shoe including the lower valve plate and stem cap nut shall have a protective coating that meets the requirements of AWWA C-550. If a stem cap nut is utilized, it must be locked in place by a stainless steel lock washer or similar non-corrosive device that will prevent the cap nut from backing-off during normal use.

The hydrant shall be coated with a prime coat and two finish coats of paint as suggested by the manufacturer and approved by the Engineer. The shop drawings shall indicate the coating and color proposal.

Hydrants shall be warranted by the manufacturer against defects in materials or workmanship for a period of ten years (10) from the date of manufacture. Hydrants shall be Mueller Super Centurion 250 or approved equal.

Hydrant adapters shall be the swivel by solid adapter with swivel gland type as manufactured by Tyler Pipe/Union Foundry Company, or approved equal.

Foster adapters shall be constructed of ductile iron and comply with applicable AWWA Standards and shall be lined and coated in accordance with AWWA C104 and C110. They shall be as manufactured by Infact Corporation, or approved equal and shall be designed for a working pressure of 250 psi.

The hydrant assembly shall be shown as on the details/drawings and as outlined in the Bid Schedule.

5.2 Installation. The hydrants shall be set in accordance with the detailed drawings complete with gate valve and connecting pipe. The hydrant shall be installed perpendicular to the surrounding ground surface and the hydrant riser shall be completely buried. The depth of bury shall be the same as the adjoining water line. The shoe of the hydrant shall be encased in Class B concrete and the concrete shall extend to undisturbed earth. Gravel shall be placed around the hydrant on top of the concrete thrust restraint and at the weep hole a minimum depth of twelve inches in depth. Select earth backfill shall be compacted to fill the remaining excavated void and the surface shall match the surrounding surface. The hydrant shall be secured to the companion gate valve by means of a hydrant adapter and pipe restrainer or by other approved means. The hydrant adapter shall be the swivel by solid adapter with swivel gland type. The direct connection of mechanical joint (MJ) fittings between the valves and tee shall be made using Foster adapters as indicated on the Drawings.

Where applicable, the contractor is also responsible under this bid item for the abandonment of existing hydrants located on water lines to be de-commissioned as part of this project. This includes removing all remnants of the hydrant and all other related appurtenances to a point two feet below existing ground level. Any void created by removal of items shall be backfilled with the adjacent area being restored to match the surrounding ground conditions including any incidental pavement replacement which may be required.

5.3 Payment. The unit price bid shall constitute full compensation for furnishing and installing the hydrant, gate valve, up to ten feet of water line, and any associated pipe fittings required to install the hydrant to the main water line.

SECTION 6 – BLOWOFF ASSEMBLY

6.0 Work Included. Under this item the Contractor shall provide all labor, tools, equipment, and materials to install the Blowoff Assemblies as shown on the drawings and as directed.

6.1 Materials. Blowoff Assemblies shall consist of the valve, pipe, and fittings in accordance with these specifications and the corresponding drawings. The gate valve and piping shall be the same size and pressure class as the line it is connected to unless otherwise noted. A post style hydrant shall be provided as the blowoff, and shall be self-draining and non-freezing. The blowoff hydrants shall be #2 Eclipse Post Hydrant as manufactured by John C. Kupferle Company, St. Louis, MO or approved equal.

6.2 Installation. The Blowoff Assembly shall be installed at the locations as shown on the drawings and as outlined on the detail drawings.

6.3 Payment. The unit price bid shall constitute full compensation for the furnishing and installation of each Blowoff Assembly to include one gate valve, piping, blocking, valve box, fittings, post hydrant and gravel.

SECTION 7 - CONNECTION

7.0 Work Included. Under this item the Contractor shall provide all labor, tools, equipment, and materials to connect and disconnect water mains as shown on the drawings and as directed.

7.1 Materials. The connections and disconnects shall be performed by the use of ductile iron mechanical joint fittings, approved tapping valves and sleeves, and water main pipe as shown on the drawings described elsewhere in these technical specifications. Concrete for thrust restraint shall be Class B concrete and sack-crete shall not be allowed.

7.2 Installation. Unless otherwise noted on the plans, connections shall be made with a tapping sleeve and valve and done so in accordance with the Owners schedule of operation. Once the main line has been tapped the new section of water main shall be valved off from the rest of the system by closing the tapping valve. The tapping valve shall remain closed until the Engineer has been satisfied that the new water main has been installed correctly, met the requirements of the hydrostatic test, been sanitized in accordance with the regulatory requirements, and any water main to be abandoned has been disconnected from the water system.

The disconnection of a water main that is to be abandoned shall be accomplished by installing a blind flange at the point of abandonment and secured by means of a concrete thrust block. In the event where the thrust block shall be installed in the area of the abandoned water main a minimum three foot section of the abandoned water main shall be removed and the void replaced with concrete.

7.3 Payment. The unit price bid shall constitute full compensation for furnishing and installing the connections including any abandonment or disconnections of existing water mains. This shall include all fittings but water mains and gate valves shall be paid as per the bid schedule for those respective items.

SECTION 8 – AIR RELEASE VALVE

8.0 Scope of Work. Under this item the Contractor shall provide all labor, tools, equipment and materials to install automatic air release valves as shown on the drawings and as directed.

8.1 Materials. All air release valves shall be automatic float operated valves designed to release accumulated air from a piping system while the system is in operation and under pressure. Valves shall be manufactured and tested in accordance with American Water Works Association (AWWA). The manufacturer shall have a quality management system that is certified to ISO 9001 by an accredited, certifying body. Valves used in potable water service shall be certified to NSF/ANSI 61 Drinking Water System Components - Health Effects.

Valves 3 in. (76mm) and smaller shall be threaded with NPT inlets and outlets. The body inlet connection shall be hexagonal for a wrench connection. Larger valves shall have ANSI Class 125 flanged inlets. The valve shall have two additional NPT connections for the addition of gauges, testing, and draining. The cover shall be bolted to the valve body and sealed with a flat gasket. Resilient seats shall be replaceable and provide drop tight shut off to the full valve pressure rating. Floats shall be unconditionally guaranteed against failure including pressure surges. Mechanical linkage shall provide sufficient mechanical advantage so that the valve will open under full operating pressure. Simple lever designs shall consist of a single pivot arm and a resilient orifice button. Compound lever designs shall consist of two levers and an adjustable threaded resilient orifice button. A fully-ported brass ball valve shall be provided when specified to isolate the air release valve from the piping system.

The valve body and cover shall be constructed of ASTM A126 Class B cast iron for working pressures up to 300 psig. Higher pressure rated valves shall be constructed of ASTM A536 Grade 65-45-12 ductile iron. The orifice, float and linkage mechanism shall be constructed of Type 316 stainless steel. Non-metallic floats or linkage mechanisms are not acceptable. The orifice button shall be Viton for simple lever valves and Buna-N for compound lever designs. Valve interiors and exteriors shall be coated with an NSF/ANSI 61 certified fusion bonded epoxy in accordance with AWWA C550. The exterior of the valve shall be coated with a universal alkyd primer.

All valves installed in vaults or flood prone locations shall include an inflow preventer to prevent the introduction of contaminated water through the air valve outlet. The inflow preventer shall allow the admittance and exhausting of air while preventing contaminated water from entering during normal operating conditions. The inflow preventer shall be flow tested by an independent third party to certify performance. The third party shall be an approved testing lab of the American Society of Sanitary Engineers.

The manufacturer shall demonstrate a minimum of (5) years experience in the manufacture of air valves. When requested, the manufacturer shall provide test certificates, dimensional drawings, parts list drawings, and operation and maintenance manuals.

Air Release Valves shall be Series 50 as manufactured by Val-Matic Valve and Manufacturing Corporation or approved equal.

8.2 Installation. Valve installation shall be as shown on the drawings and standard details. The valve vault shall be one section of a 4-foot manhole barrel with a precast concrete top section. The top shall consist of a vented manhole lid cast flush within the concrete top. The top shall also include a 2-inch steel pipe for use as a vent and the pipe shall be either 'U' shaped or as directed by the Engineer, shop primed and painted. The vent shall be equipped with an insect screen.

The valves shall be connected to the force main with a saddle, corporation stop, a 6-inch long riser pipe, a 2-inch ball valve, and a 2-inch long nipple. The nipple shall be equipped with a 3/8-inch tap with a shutoff connection for a pressure gauge.

8.3 Payment. The unit price shall constitute full compensation for the furnishing and installation of the air release valve assembly including the air release valve, pit, lid and required piping.

SECTION 9 -DIRECTIONAL DRILLING / BORING

9.0 Scope of Work. It is intent of this specification to define the acceptable methods and materials for installing water lines by the horizontal directional drilling method and the requirements for high density polyethylene (HDPE) pipe installed by horizontal directional drilling, directional boring, guided boring or in open cut trenches.

9.1 Requirements. Contractor shall provide HDPE pipe conforming to all standards and procedures, and meeting all testing and material properties as described in this specification for installation by horizontal directional drilling.

The estimated length of each directional bore is indicated on the plan sheets. This stated length shall be the footage used for the contractors payment calculation regardless of the actual length required for installation.

Contractor shall be responsible for all installation processes and procedures associated with the installation by horizontal directional drilling in accordance with this specification.

9.2 Installation Plan. At least 7 days prior to mobilizing equipment, Contractor shall submit his detailed installation plan to the Engineer.

The plan shall also include a listing of major equipment and supervisory personnel and a description of the methods to be used.

9.3 Variations in Plan or Profile. The Contractor may request changes to the proposed vertical and horizontal alignment of the installation and the location of the entry and exit points. Proposed changes shall be submitted in writing to the Engineer and receive approval of the Engineer prior to construction.

9.4 Alignment. The proposed plan and profile installation locations are based on alignments to accommodate acquired right-of-way, to avoid obstructions, and to properly maintain operation flow velocities.

9.5 Qualifications. Directional drilling and pipe installation shall be done only by an experienced Contractor specializing in directional drilling and whose key personnel have at least five (5) years experience in this work. Furthermore, the Contractor shall have installed directional drilled pipe at least as large as 18 inches in diameter, have performed crossings at least 650 feet in length, and successfully installed at least 2000 feet in length.

9.6 Products. High Density Polyethylene (HDPE) pipe accordance to these specifications shall be used in HDD installations. All piping system components shall be the products of one manufacturer and shall conform to the latest edition of ASTM D2447, ASTM D3350, and ASTM F714 for HDPE.

Pipe shall conform to the dimensionality and general characteristics of the mainline carrier piping to which it will be connected to. The inside diameter of the pipe to be used in HDD applications shall be equal to or greater than that of the mainline carrier piping.

9.7 Piping. Piping shall be extruded from a polyethylene compound and shall conform to the following requirements:

The polyethylene resin shall meet or exceed the requirements of ASTM D3350 for PE 3408 material with a cell classification of 335434C, or better. The polyethylene compound shall be suitably protected against degradation by ultraviolet light by means of carbon black, well dispersed by precompounding in a concentration of not less than 2 percent.

The maximum allowable hoop stress shall be 800 psi at 73.4 degrees F.

The pipe manufacturer shall be listed with the Plastic Pipe Institute as meeting the recipe and mixing requirements of the resin manufacturer for the resin used to manufacture the pipe in this project.

Joining shall be performed by thermal butt-fusion in accordance with the manufacturer's recommendations.

9.8 Concrete Restraint Wall. The contractor shall install a concrete restraint wall on each end of the HDD piping. The wall should be constructed as shown in the miscellaneous detail drawings. Details on concrete construction are included elsewhere in these specifications.

9.9 Execution. All HDD pipes shall be cut, fabricated, and installed in strict conformance with the pipe manufacturer's recommendations. Joining, laying, and pulling of HDD pipe shall be accomplished by personnel experienced in working with HDD pipe being used. The pipe supplier shall certify in writing that the Contractor is qualified to join, lay, and pull the pipe or representative of the pipe manufacturer shall be on site to oversee the pipe joining. Expense for the representative shall be paid for by the Contractor.

9.10 Transportation and Unloading. All pipe shall be bundled or packaged in such a manner as to provide adequate protection of the ends during transportation to the site. Care shall be taken during transportation of the pipe to ensure that it is not cut, kinked, or otherwise damaged. Any pipe damaged in shipment shall be replaced as directed by the owner or engineer.

Each pipe shipment should be inspected prior to unloading to see if the load has shifted or otherwise been damaged. Notify owner or engineer immediately if more than immaterial damage is found. Each pipe shipment should be checked for quantity and proper pipe size, color, and type.

Pipe should be loaded, off-loaded, and otherwise handled in accordance with AWWA M23, and all of the pipe supplier's guidelines shall be followed. Off-loading devices such as chains, wire rope, chokers, or other pipe handling implements that may scratch, nick, cut, or gouge the pipe are strictly prohibited.

During removal and handling, be sure that the pipe does not strike anything. Significant impact could cause damage, particularly during cold weather.

If appropriate unloading equipment is not available, pipe may be unloaded by removing individual pieces. Care should be taken to insure that pipe is not dropped or damaged. Pipe should be carefully lowered, not dropped, from trucks.

9.11 Handling and Storage. Any length of pipe showing a crack or which has received a blow that may have caused an incident fracture, even though no such fracture can be seen, shall be marked as rejected and removed at once from the work. Damaged areas, or possible areas of damage may be removed by cutting out and removing the suspected incident fracture area. Limits of the acceptable length of pipe shall be determined by the owner or engineer. Any scratch or gouge greater than 10% of the wall thickness will be considered significant and can be rejected unless determined acceptable by the owner or engineer.

Pipe shall be stored and stacked per the pipe supplier's guidelines. Pipe lengths should be stored and placed on level ground. Pipe should be stored at the job site in the unit packaging provided by the manufacturer. Caution should be exercised to avoid compression, damage, or deformation to the ends of the pipe. . If pipe is to be stored for periods of 1 year or longer, the pipe should be shaded or otherwise shielded from direct sunlight. Covering of the pipe which allows for temperature build-up is strictly prohibited. Pipe should be covered with an opaque material while permitting adequate air circulation above and around the pipe as required to prevent excess heat accumulation.

The open ends of all sections of joined and/or installed pipe (not in service) shall be plugged at night to prevent animals or foreign material from entering the pipe line or pipe section. Waterproof nightcaps of approved design may be used but they shall also be so constructed that they will prevent the entrance of any type of natural precipitation into the pipe and will e fastened to the pipe in such a manner that the wind cannot blow them loose. The practice of stuffing cloth or paper in the open ends of the pipe will be considered unacceptable.

Pipe shall be handled and supported with the use of woven fiber pipe slings or approved equal. Care shall be exercised when handling the pipe to not cut, gouge, scratch or otherwise abrade the piping in any way. Where possible, the pipe shall be raised and supported at a suitable distance back from the open end such that the open end will be below the level of the pipe at the point of support.

9.12 Installation.

The Contractor shall install the pipelines by means of horizontal directional drilling. The Contractor shall assemble, support, and pretest the pipeline prior to installation in the directional drill tunnel.

Horizontal directional drilling shall consist of the drilling of a small diameter pilot hole from one end of the alignment to the other, followed by enlarging the hole diameter for the pipeline insertion. The exact method and techniques for completing the directionally drilled installation will be determined by the Contractor, subject to the requirements of these Specifications.

The Contractor shall prepare and submit a plan to the Engineer for approval for insertion of the HDD pipe into the opened bore hole. This plan shall include pullback procedures, ballasting, use of rollers, side booms and side rollers, coating protection, internal cleaning, internal gauging, hydrostatic tests, dewatering, and purging.

The required piping shall be assembled in a manner that does not obstruct adjacent roadways or public activities. The Contractor shall erect temporary fencing around the entry and exit pipe staging areas.

9.13 Joining Pipe Sections. The joining of pipe sections shall be completed by a Fusion Technician who is fully qualified by the pipe supplier to install the HDD pipe of the type(s) and size(s) being used. Qualification shall be current as of the actual date of fusion performance on the project.

HDD pipe will be handled in a safe and non-destructive manner before, during, and after the fusion process and in accordance with this specification and pipe supplier's guidelines. The fusion process shall be performed by qualified fusion technicians, as documented by the pipe supplier. Each fusion joint shall be recorded and logged by an electronic monitoring device (data logger) connected to the fusion machine.

Only appropriately sized and outfitted fusion machines that have been approved by the pipe supplier shall be used for the fusion process. Fusion machines must incorporate the following elements:

HEAT PLATE - Heat plates shall be in good condition with no deep gouges or scratches. Plates shall be clean and free of any debris or contamination. Heater controls shall function properly; cord and plug shall be in good condition. The appropriately sized heat plate shall be capable of maintaining a uniform and consistent heat profile and temperature for the size of pipe being fused, per the pipe supplier's guidelines.

CARRIAGE – Carriage shall travel smoothly with no binding at less than 50 psi. Jaws shall be in good condition with proper inserts for the pipe size being fused. Insert pins shall be installed with no interference to carriage travel.

GENERAL MACHINE - Overview of machine body shall yield no obvious defects, missing parts, or potential safety issues during fusion.

DATA LOGGING DEVICE – An approved datalogging device with the current version of the pipe supplier’s recommended and compatible software shall be used. Datalogging device operations and maintenance manual shall be with the unit at all times. If fusing for extended periods of time, an independent 110V power source shall be available to extend battery life.

Other equipment specifically required for the fusion process shall be used as necessary. Pipe rollers shall be used for support of pipe to either side of the machine. A weather protection canopy that allows full machine motion of the heat plate, fusion assembly and carriage shall be provided for fusion in inclement, extreme temperatures, and /or windy weather, per the pipe supplier’s recommendations. An infrared (IR) pyrometer for checking pipe and heat plate temperatures. Fusion machine operations and maintenance manual shall be kept with the fusion machine at all times. Facing blades specifically designed for cutting HDPE pipe shall be used.

Each fusion joint shall be recorded and logged by an electronic monitoring device (data logger) connected to the fusion machine. The fusion data logging and joint report shall be generated by software developed specifically for the butt-fusion of HDPE. The software shall register and/or record the parameters required by the pipe supplier and these specifications. Data not logged by the data logger shall be logged manually and be included in the Fusion Technician’s joint report.

9.14 Testing. The pipe shall be hydrostatically tested after joining into continuous lengths prior to installation and again after installation. Pressure and temperature shall be monitored with certified instruments during the test. After this test, the water will be removed with pigs. Erosion prevention procedures will be used during removal and discharge of the water. Hydrostatic testing shall be performed in accordance with Section 1 of the Specifications. All costs associated with acquiring water for testing shall be included in the established contract unit bid prices.

9.15 Tolerances. Pipe installed by the directional drilled method must be located in plan as shown on the Drawings, and must be no shallower than shown on the Drawings unless otherwise approved. The Contractor shall plot the actual horizontal and vertical alignment of the pilot bore at intervals not exceeding 30 feet. This “as built” plan and profile shall be updated as the pilot bore is advanced. The Contractor shall at all times provide and maintain instrumentation that will accurately locate the pilot hole and measure drilling fluid flow and pressure. The Contractor shall grant the Engineer access to all data and readout pertaining to the position of the bore head and the fluid pressures and flows.

When requested, the Contractor shall provide explanations of this position monitoring and steering equipment. The Contractor shall employ experienced personnel to operate the directional drilling equipment and, in particular, the position monitoring and steering equipment. No information pertaining to the position or inclination of the pilot bores shall be withheld from the Engineer.

Sags in the pipeline shall not exceed 5 percent of the nominal pipe diameter. Sags will only be allowed where the entering and exiting grades are adequate to provide velocities through the sag area sufficient for moving solids. No more than (1) sag area shall occur between two (2) manholes. The alignment of each pilot bore must be approved by the Engineer before pipe can be pulled. If the pilot bore fails to conform to the above tolerances, the Engineer may, at his option, require new pilot boring to be made.

After the pipe is in place, cleaning pigs shall be used to remove residual water and debris. After the cleaning operation, the Contractor shall provide and run a sizing pig to check for anomalies in the form of buckles, dents, excessive out-of-roundness, and any other deformations. The sizing pig run shall be considered acceptable if the survey results indicate that there are no shape anomalies (e.g. dents, buckles, gouges, and internal obstruction) greater than 2 percent of the nominal pipe diameter, or excessive ovality greater than 5 percent of the nominal pipe diameter. For gauging purposes, dent locations are those defined above which occur within a span of five feet or less. Pipe ovality shall be measured as the percent difference between the maximum and minimum pipe diameters. For gauging purposes, ovality locations are those defined above which exceed a span of five feet.

9.16 Ream and Pullback.

Reaming: Reaming operations shall be conducted to enlarge the pilot after acceptance of the pilot bore. The number and size of such reaming operations shall be conducted at the discretion of the Contractor.

Pulling Loads: The maximum allowable pull exerted on the HDD pipelines shall be measured continuously and limited to the maximum allowed by the pipe manufacturer so that the pipe or joints are not over stressed.

Torsion and Stresses: A swivel shall be used to connect the pipeline to the drill pipe to prevent torsional stresses from occurring in the pipe. The lead end of the pipe shall be closed during the pullback operation.

Pipeline Support: The pipelines shall be adequately supported by rollers and side booms and monitored during installation so as to prevent over stressing or buckling during the pullback operation. Such support/rollers shall be spaced at a maximum of 60 feet on centers, and the rollers to be comprised of a nonabrasive material arranged in a manner to provide support to the bottom and bottom quarter points of the pipeline allowing for free movement of the pipeline during pullback. Surface damage shall be repaired by the Contractor before pulling operations resume.

The contractor shall at all times handle the HDD pipe in a manner that does not over stress the pipe. Vertical and horizontal curves shall be limited so that wall stresses do not exceed 50% of yield stress for flexural bending of the pipe. If the pipe is buckled or otherwise damaged, the damaged section shall be removed and replaced by the Contractor at his expense. The Contractor shall take appropriate steps during pullback to ensure that the pipe will be installed without damage.

9.17 Handling Drilling Fluids and Cuttings.

During the drilling, reaming, or pullback operations, the Contractor shall make adequate provisions for handling the drilling fluids, or cuttings at the entry and exit pits. These fluids must not be discharged into the waterway. When the Contractor's provisions for storage of the fluids or cuttings on site are exceeded, these materials shall be hauled away to a suitable legal disposal site. The Contractor shall conduct his directional drilling operation in such a manner that drilling fluids are not forced through the sub-bottom into the waterway. After completion of the directional drilling work, the entry and exit pit locations shall be restored to original conditions. The Contractor shall comply with all permit provisions.

Pits constructed at the entry or exit point area shall be so constructed to completely contain the drill fluid and prevent its escape to the waterway. The Contractor shall utilize drilling tools and procedures which will minimize the discharge of any drill fluids. The Contractor shall comply with all mitigation measures listed in the required permits and elsewhere in these Specifications.

To the extent practical, the Contractor shall maintain a closed loop drilling fluid system.

The Contractor shall minimize drilling fluid disposal quantities by utilizing a drilling fluid cleaning system which allows the returned fluids to be used.

As part of the installation plan specified herein before, the Contractor shall submit a drilling fluid plan which details types of drilling fluids, cleaning and recycling equipment, estimated flow rates, and procedures for minimizing drilling fluid escape.

9.18 Drilling Operations.

The Contractor shall prepare a plan to be submitted for Engineer approval which describes the noise reduction program, solids control plant, pilot hole drilling procedure, the reaming operation, and the pullback procedure. All drilling operations shall be performed by supervisors and personnel experienced in horizontal directional drilling. All required support, including drilling tool suppliers, survey systems, mud cleaning, mud disposal, and other required support systems used during this operation shall be provided by the Contractor.

Drill pipe shall be API steel drill pipe, Range 2, Premium Class or higher, Grade S-135 in a diameter sufficient for the torque and longitudinal loads and fluid capacities required for the work. Only drill pipe inspected under API's Recommended Practice Specification

API RP 7G within 30 days prior to start and certified as double white band or better shall be used.

A smoothly drilled pilot hole shall follow the design centerline of the pipe profile and alignment described on the construction drawings.

Between the entry or exit point the Contractor shall provide and use a separate steering system employing a ground survey grid system, such as "TRU-TRACKER" or equal wherever possible. The exit point shall fall within a rectangle 5 feet wide and 10 feet long centered on the planned exit point.

During the entire operation, waste and leftover drilling fluids from the pits and cuttings shall be dewatered and disposed of in accordance with all permits and regulatory agencies requirements. Remaining water shall be cleaned by Contractor to meet permit requirements.

Technical criteria for bentonite shall be as given in API Spec. 13A, Specification of Oil Well Drilling Fluids Material for fresh water drilling fluids. Any modification to the basic drilling fluid involving additives must describe the type of material to be used and be included in Contractor's drilling plan presented to the Engineer. The Owner retains the right to sample and monitor the waste drilling mud, cuttings and water.

9.19 Environmental Provisions.

The Horizontal Directional Drilling operation is to be operated in a manner to eliminate the discharge of water, drilling mud and cuttings to the adjacent creek or land areas involved during the construction process. The Contractor shall provide equipment and procedures to maximize the recirculation or reuse of drilling mud to minimize waste. All excavated pits used in the drilling operation shall be lined by Contractor with heavy duty plastic sheeting with sealed joints to prevent the immigration of drilling fluids and/or groundwater.

The Contractor shall visit the site and must be aware of all structures and site limitations at the directional drill crossing and provide the Engineer with a drilling plan outlining procedures to prevent drilling fluid from adversely affecting the surrounding area.

The general work areas on the entry and exit sides of the crossing shall be enclosed by a berm to contain unplanned spills or discharge.

Waste cuttings and drilling mud shall be processed through a solids control plant comprised as a minimum of sumps, pumps, tanks, desalter/desander, centrifuges, material handlers, and haulers all in a quantity sufficient to perform the cleaning/separating operation without interference with the drilling program. The cutting and excess drilling fluids shall be dewatered and dried by the Contractor to the extent necessary for disposal in offsite landfills. Water from the dewatering process shall be treated by the Contractor to meet permit requirements and disposed of locally. The cuttings and water for disposal

of locally. The cuttings and water for disposal are subject to being sampled and tested. The construction site and adjacent areas will be checked frequently for signs of unplanned leaks or seeps.

Equipment (graders, shovels, etc.) and materials (such as groundsheets, hay bales, booms, and absorbent pads) for cleanup and contingencies shall be provided in sufficient quantities by the Contractor and maintained at all sites for use in the event of inadvertent leaks, seeps or spills.

Waste drilling mud and cuttings shall be dewatered, dried, and stock piled such that it can be loaded by a front end loader, transferred to a truck and hauled offsite to a suitable legal disposal site. The maximum allowed water content of these solids is 50% of weight. Due to a limited storage space at the worksite, dewatering and disposal work shall be concurrent with drilling operations. Treatment of water shall satisfy regulatory agencies before it is discharged.

9.20 Payment. Payment shall be included in the payment for the work as shown on the plan sheets and to which it is subsidiary in the Bid Schedule. The estimated length of each directional bore is indicated on the plan sheets. This stated length shall be the footage used for the contractors payment calculation regardless of the actual length required for installation.

SECTION 10 - METER SETTING & METER RECONNECTION

10.0 Work Included. Under this item the Contractor shall provide all labor, tools, equipment, and materials to install the meter settings, meter reconnects, and service tubing as shown on the drawings and as directed.

10.1 Materials. The meter settings shall consist of a saddle, corporation stop, service tubing, coppersetter, meter, meter box, and appurtenances. The corporation stops/ball valves shall be B11-333 as manufactured by Ford with a pack joint for polyethylene pipe. Pack joint inlet couplings shall be C14-33-Q as manufactured by Ford for polyethylene pipe. Saddles shall be equal to the Ford S70 Series with a hinged pin for PVC and 202 Series for ductile iron. The coppersetter shall be equal to the Ford 70 Series Coppersetter VHH72-7W-11-33 with a seven inch rise for a 5/8 inch by 3/4 inch meter and complete with an inlet key valve and outlet dual check valve. A tandem coppersetter to accommodate a pressure reducer and meter shall be used where specified. The pressure reducing valve shall be Mueller, Model No. H-9300 No. 3, or approved equal with a bronze strainer. Each regulator is to have an adjustable pressure range of 60-125 psi and to be set at 70 psi.

The meters shall be Velocity-type flow measurement type. Water shall be evenly distributed by multiple converging inlet ports flows past an impeller in the measuring chamber, creating an impeller velocity directly proportional to water flow rate. The meter shall include rugged, 360-degree advance polymer basket strainer which protects the measuring element from damage. The strainer shall be designed to smooth the flow of water entering into the meter creating a laminar flow that is gentle on the meter's internal components.

The measuring chamber housing and measurement element shall be constructed of with an advanced synthetic polymer. The meter shall be designed such that measurement surfaces are not wear surfaces, providing sustained accuracy despite the presence of entrained solids in the water. A synthetic sapphire bearing shall serve as the wear surface with radially balanced water flows. The chamber housing shall be constructed in two parts to allow access to the impeller. The bottom plates shall be manufactured of Engineered Plastic.

They shall conform to American Water Works Standard C-708 as most recently revised with respect to accuracy and pressure loss requirements, or other appropriate American Water Works Standard. Must be compliant with NSF/ANSI Standard 61 Annex F and G. System shall operate up to a working pressure of 200 pounds per square inch (psi), without leakage or damage to any parts. The accuracy shall not be affected by variation of pressure up to 200 psi.

The measuring element shall be made of a noncorrosive, lead-free glass fiber reinforced, composite alloy material. A battery powered magnetic flow sensor utilizing silver/silver chloride electrodes will be utilized to measure the velocity of the water which is linearly proportional to the volume. The measuring element will have no moving parts and will be specific for each size. The register and measuring element will be an integrated unit housed within a thermal plastic external casing. This integrated unit will not be removable from the external housing. The systems shall have the size and direction of water flow through the system imprinted on the external housing.

The meter shall be supplied with AMR System registers which display measurement in U.S. Gallons, and houses all vital components, including encoder, RF transmitter, battery and antenna. The registers shall be permanently sealed with a scratch resistant, tempered glass lens, stainless steel base and wrap-around gasket to prevent intrusion of dirt or moisture. The registers shall feature large center sweep hand with one hundred (100) clearly marked gradations on the periphery of the dial face.

Meters shall be Master Meter Multi Jet equipped with a DIALOG 3G register. Meters and radio read transceivers shall be compatible with the Owners current radio read metering system.

The meter boxes shall be green corrugated polyethylene round boxes (un-notched, smooth interior) and shall be 15-inches in diameter and 24-inches deep as manufactured by Hancor, Inc., or approved equal. For traffic rated applications, meter boxes shall be a round reinforced concrete pipe section 18-inches in diameter and 30-inches deep. Meter box settings shall be prefabricated with the copper-setters and fittings as specified ready for connection at the inlet and outlet ends. Meter box settings shall be that as manufactured by Water Works Supplies, Inc., Richmond, Kentucky, or approved equal. Meter boxes shall include a two piece flat cast iron lid and frame, RUSSCO LC-219 as manufactured by Sigma Corporation, or approved equal. For traffic rated applications, the meter box cover shall be a Double Extra Heavy Frame and a locking type Extra Heavy Lid, Type A, Catalog No. A32HH, as manufactured by The Ford Meter Box Company, Inc. or approved equal.

Service tubing shall be 3/4 inch polyethylene or type K copper tubing with a minimum pressure rating of 200 PSI. One-inch and two-inch service lines shall be PVC, PE, or K copper with a minimum pressure rating of 200 PSI. Insert stiffeners shall be used when using polyethylene service tubing and shall be Series 50 or 70 as manufactured by Ford Meter Box Company, Inc., or approved equal.

10.2 Installation. Meter settings shall be supplied and installed as shown on the detail drawings with backfill neatly compacted in place. The top of the meter box shall be set 1/2 inch above grade in non-pavement applications. In pavement applications, the top of the meter box shall be set flush with the top of the pavement. In all cases, the meter shall be at least 18 inches below the ground surface.

Where applicable, the contractor is also responsible under this bid item for the abandonment of the existing meter settings. This includes disconnection at the direction of the engineer, removing all remnants of the meter box/vault and all other related appurtenances to a point two feet below existing ground level. Any void created by removal of items shall be backfilled with the adjacent area being restored to match the surrounding ground conditions including any incidental pavement replacement which may be required. All existing interior piping, meters, valves, and other appurtenances shall be removed and delivered to the owner prior to demolition and removal of the existing meter box/vault.

Meter reconnects shall consist of reestablishing service to an existing meter after the new water main has been installed. Unless shown otherwise, the new service line shall be installed to connect the new water main to the existing service line at the closest location possible. The new and existing service line shall be connected using an approved brass compression coupling.

Service line reconnects shall consist of reestablishing service on the customer side of a new meter. New service line shall be installed to connect the new water main to the existing service line at the closest location possible. The new and existing service line shall be connected using an approved brass compression coupling. A new customer shut off valve should be installed on the customer side of the meter in those instances where a new meter setting is being installed to replace an existing meter setting with a customer side shutoff valve. See Sheet SD-2 for details regarding the customer side shutoff valve installation.

10.3 Payment. The unit price bid shall constitute full compensation for furnishing and installing the meter setting, or meter reconnect, with the above described appurtenances. Service tubing shall be paid by the linear foot. Installation of the service tubing through or beneath paved surfaces shall be considered as an incidental cost for the installation of the service tubing and there shall be no compensation for pavement replacement.

SECTION 11 - STONE AGGREGATE

11.0 Work Included. Under this item the Contractor shall provide all labor, tools, equipment, and materials to install the stone aggregate as shown on the drawings and as directed.

11.1 Materials. The stone aggregate shall be dense grade stone #9 or as directed by the Engineer or as otherwise shown. The stone shall be free of dirt, sand, trash, debris, and free water.

11.2 Installation. The Contractor shall install the aggregate at the locations as shown on the drawings which includes any trenches where the water main or service line disturbs any roadway. This also includes any areas where casing pipe is installed in open trenches or the locations where a bore or receiving pit was excavated. Stone shall be backfilled to top of grade where any trenches disturb paved areas. The Engineer may limit the amount of stone to be placed upon determination that the application is excessive.

11.3 Payment. Stone aggregate shall be incidental to the installation of the water mains, and other appurtenances. There shall be no separate pay item for stone aggregate.

SECTION 12- PAVEMENT REPLACEMENT

12.0 Work Included. Under this item the Contractor shall provide all labor, tools, equipment, and materials to install concrete and bituminous pavement replacement where pavement is disturbed during construction.

12.1 Materials. Pavement replacement for bituminous surfaces shall consist of a prime coat of emulsified asphalt, Class 1 Bituminous Binder, and Class 1 Bituminous Asphalt as specified by the Kentucky Bureau of Highways latest specifications.

Pavement replacement for concrete surfaces shall consist of Class A concrete including reinforcement consisting of No. 4 reinforcing bars placed on twelve inch centers in both directions or otherwise as directed by the engineer.

Support backfill shall be No. 9 stone, dense grade aggregate or flowable fill as per the detailed drawings and specifications herein.

12.2 Installation. Immediately upon placement of the water lines and appurtenances the disturbed traveled way shall be backfilled with No. 9 stone or dense grade aggregate extending from the top of the pipe up to the traveled way surface. The area of disturbance will be repaved once settlement has subsided granted that water line installation, testing and all other cleanup has been completed as dictated by the Engineer.

In preparation for the installation of pavement replacement, the top twelve inches of stone backfill shall be compacted with a mechanical tamping machine. The use of rubber tire or track driven equipment such as backhoes or dozers shall not satisfy the requirement for final compaction.

12.2.1 State Highway Pavement Replacement. Where bituminous pavement replacement is required due to a disturbance of a Kentucky State Highway, the trench shall be backfilled with #9 stone up to 9-inches below the top of the existing pavement. The stone shall be properly compacted and capped with a 6-inch layer of KYDOT approved flowable fill. A 3-inch layer of temporary asphalt pavement shall then be installed flush with the level of the existing pavement. Upon completion of the water line installation, testing and all other cleanup, the Contractor shall mill the temporary asphalt and the existing asphalt in preparation for final pavement replacement. The total width of final pavement replacement shall be a minimum of three feet from the each edge of temporary pavement. Following milling of existing and temporary pavement, the Contractor shall replace void with an approved prime coat of emulsified asphalt applied at a rate of 0.35 gallons per square yard and a 3-inch finish coat asphalt pavement. The pavement shall be rolled to a smooth finish and provide a gentle transition to the existing pavement.

12.2.2 Full Width Pavement Replacement. Where full width bituminous pavement replacement is required, the pipe trench shall be backfilled as described herein. Upon completion of the water line installation, testing and all other cleanup, the Contractor shall install full width pavement replacement in all areas indicated on the plans. In areas where existing curbing is in place, the contractor shall mill the existing paved surface before new asphalt pavement overlay is installed. In areas where curbing is not in place, the contractor shall install asphalt overlay directly atop existing pavement. An approved prime coat of emulsified asphalt applied at a rate of 0.35 gallons per square yard shall be applied in preparation of for installation of the asphalt overlay. The finish coat of asphalt pavement shall be a minimum of 2-inches across the entire roadway cross-section. The pavement shall be rolled to a smooth finish and provide a gentle transition to all existing pavement. All transitions from new pavement to existing pavements shall be sealed using a KYTC approved hot poured elastic type joint seal compound.

12.2.3 Incidental Pavement Replacement. Unless specifically noted otherwise, pavement replacement shall be incidental to the cost of installing the water line. This includes all driveways, parking lots, city street/county road crossings, and all other locations where state highway or full-width pavement replacement isn't specifically noted on the plans. Where incidental pavement replacement, including partial pavement replacement and partial pavement replacement to the roadway centerline is required, the pipe trench shall be backfilled as described herein. Upon completion of the water line installation, testing and cleanup, the Contractor shall install pavement replacement in all areas where the existing pavement has been disturbed. The total width of pavement replacement shall extend a minimum of three feet outward from each edge of the pipeline trench. Partial pavement replacement will be required when pavement is disturbed along the edge of a paved area. In partial pavement replacement situations the replacement pavement shall extend into the paved area a minimum three feet and toward the pipeline trench to a point equal to that of the existing pavement. In partial pavement replacement to the centerline of the roadway situations, the replacement pavement shall encompass the entire side of the roadway (to the approximate centerline) which was disturbed. In all cases, the transition from the replacement pavement and the existing pavement shall be saw cut with a neat and clean appearance. All existing pavement material within the total width of the pavement replacement area shall be removed by milling or other means prior to installation of new pavement. All transitions from new pavement to existing pavements shall be sealed using a KYTC approved hot poured elastic type joint seal compound.

Where concrete pavement replacement is required, reinforcing steel shall be placed within three inches of the surface of the existing concrete and it shall be supported with CMU support pieces. The area to be repaved shall be formed to coincide with the adjoining concrete surfaces and the edges of the repaved area shall be smooth and uniform. The concrete shall be placed on top of the compacted gravel at a minimum depth of six inches. The surface finish shall match that of the adjoining concrete. The transition to all adjoining pavement shall be smooth and uniform such that ponding will not occur.

Where bituminous pavement replacement is required the base shall be prepared with a prime coat of emulsified asphalt applied at a rate of 0.35 gallons per square yard. A 3-inch thick layer of bituminous binder shall then be placed above the prime coat. The final coat of bituminous concrete shall then be placed at a depth of 2-inches. The final coat of pavement shall be rolled to a smooth finish and provide gentle transitions to all existing pavement.

Detail illustrations regarding the methods described have been included in the standard drawings.

12.3 Final Acceptance. All pavement replacement shall be inspected prior to the final warranty period expiration. Any pavement replacement found to be deteriorated or not uniform due to settlement of the disturbed subsurface shall be repaired before the work is recommended for final acceptance. It is anticipated that this inspection shall take place on or about the eleventh month of the one year warranty period. The warranty period for all pavement replacement shall not commence until the final warranty period for the project in its entirety is initiated.

12.4 Payment. The unit price bid shall constitute full compensation for furnishing and installing pavement replacement as it is outlined in the bid schedule and specifications herein. Unit measurement of all pavement replacement not considered incidental shall be in linear feet, with the measurement being taken parallel to the corresponding pipeline trench

All disturbed pavement which is not specifically indicated on the plans as receiving state highway or full-width pavement replacement shall be considered incidental to the cost of installing the water lines and shall receive no additional payment.

SECTION 13 - EXPLORATION

13.0 Work Included. Under this item the Contractor shall provide all labor, tools, equipment, and materials to explore for existing water lines and appurtenances that are not as shown on the Drawings.

13.1 Description of Work. In those locations where the existing water lines and appurtenances are not in the locations as shown on the Drawings the Contractor shall explore for the utility at the direction of the Engineer. The Contractor shall utilize all equipment necessary to search for the water line or appurtenance and any disturbance of other utilities shall be the responsibility of the Contractor. Any other work or disturbance created by the Contractor as a result of the exploration shall be incidental to this item.

In locations where new water lines are to be installed parallel to existing water lines or other utilities, the contractor shall locate existing lines in 100 foot intervals. This particular requirement shall be considered **incidental** to the installation of the water lines and it **shall not be included** in the calculation of this pay item.

13.2 Payment. The unit price bid shall constitute full compensation for the exploration of the water lines and appurtenances. The Resident Engineer shall approve the Contractor to initiate and terminate the exploration and the Resident Engineer shall monitor the amount of time in 15 minute increments.

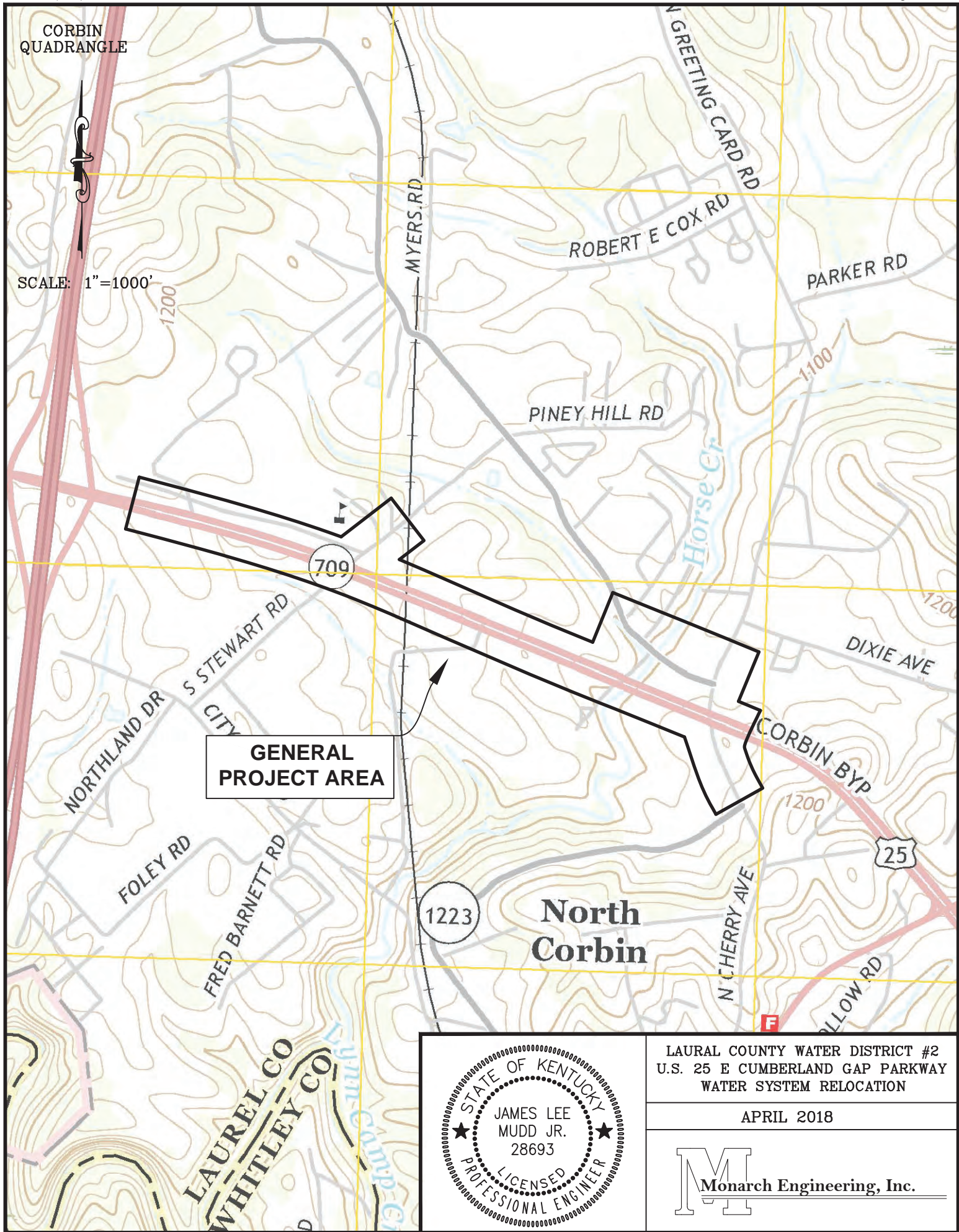

GENERAL PROJECT AREA

North Corbin

STATE OF KENTUCKY
 ★ JAMES LEE MUDD JR. ★
 28693
 LICENSED PROFESSIONAL ENGINEER

LAURAL COUNTY WATER DISTRICT #2
 U.S. 25 E CUMBERLAND GAP PARKWAY
 WATER SYSTEM RELOCATION

APRIL 2018

M
Monarch Engineering, Inc.

Corbin

City Utilities Commission

SECTION 02400

Casing Pipe

1.01 SCOPE OF WORK

- A. Provide all labor, materials, equipment and services required to furnish and install all carrier pipes in encasement pipes under railroad, highway, and creek crossings as shown on the Drawings and/or specified herein.

1.02 SUBMITTALS

- A. Descriptive literature, catalog cuts, or dimensional prints clearly indicating all dimensions and materials of construction, shall be submitted on all items specified herein to the Engineer for review before ordering. The submitted documents shall provide information indicating that the materials are in conformance with the Contract Documents.
- B. At the time of submission, the Contractor shall, in writing, call the Engineer's attention to any deviations that the submittals may have from the requirements of the Contract Drawings and Specifications.

PART 2 - PRODUCTS

2.01 CARRIER PIPE

- A. Carrier pipe shall be as specified in Section 02665 – Water Mains & Accessories.

2.02 CASING PIPE

- A. Casing pipe shall be steel, plain end, have a minimum yield point strength of 35,000 psi and conform to ASTM A 252 Grade 2 or ASTM A 139 Grade B without hydrostatic tests. The steel pipe shall have welded joints and be in at least 18 foot lengths.

02400-2
Casing Pipe

B. The diameter of the casing pipe shall be as follows:

Carrier Pipe Nominal Diameter (Inches)															
4	6	8	10	12	14	15	16	18	20	21	24	27	30	33	36
Casing Pipe Nominal Diameter (Inches)															
8	12	16	18	20	24	24	30	30	30	36	36	38	42	46	48

For carrier pipe sizes greater than 36-inches nominal diameter, the casing pipe diameter size shall be determined by the Engineer or as shown on the Contract Drawings.

C. The wall thickness of the casing pipe shall be as follows:

Carrier Pipe Nominal Diameter (Inches)							
Under 20	20 & 22	24	30	36	38	42	48
Casing Pipe Nominal Thickness (Inches)							
0.250	0.281	0.312	0.406	0.469	0.500	0.562	0.625

However, should casing pipe thickness be specified or required on Highway or Railroad permit approval sheets, said permit thickness requirement shall govern. Permit approval sheets will be made available to the Contractor.

2.03 CASING SPACERS

A. **Stainless Steel Casing Spacers:** Stainless steel casing spacers shall be bolt-on style with a shell made in two (2) sections of heavy T-304 stainless steel. Connecting flanges shall be ribbed for extra strength. The shell shall be lined with a PVC liner .090" thick with 85-90 durometer. All nuts and bolts are to be 18-8 stainless steel. Runners shall be made of ultra high molecular weight polymer with inherent high abrasion resistance and a low coefficient of friction. Runners shall be supported by risers made of heavy T-304 stainless steel. The supports shall be mig welded to the shell and all welds shall be fully passivated. Stainless steel casing spacers shall be made by Cascade Waterworks Mfg. Co., or equal.

- B. Solid Polyethylene Casing Spacers (to be used with PVC pipe only): Solid polyethylene casing spacers shall be bolt-on style with a shell made in two (2) sections. Carrier pipe shall be wrapped with rubber strap inside casing space to prevent slippage. All nuts and bolts are to be 18-8 stainless steel. Solid polyethylene casing spacers shall be made by Calpico Inc., Advance Products & Systems, Inc., or equal.

2.04 CASING END SEALS

- A. Wrap-around end seals - Wrap-around end seals shall be made of a waterproof flexible coal tar membrane reinforced with fiberglass, or synthetic rubber. The two exposed edges of the wrap-around seal shall be adhesively bonded forming a watertight seal. The ends of the wrap shall be sealed on the casing and carrier pipe by stainless steel bands. Wrap-around end seals shall be made by Calpico Inc., Advance Products & Systems, Inc., or equal.

PART 3 - EXECUTION

3.01 CROSSINGS - GENERAL

- A. Steel casing pipe for crossings shall be bored and/or jacked (or open cut installed where indicated on the Drawings) into place to the elevations shown on the drawings. All joints between lengths shall be solidly butt-welded with a smooth non-obstructing joint inside. The casing pipe shall be installed without bends. The carrier pipe shall be installed after the casing pipe is in place, and shall extend a minimum of two (2) feet beyond each end of the casing to facilitate making joint connections. The carrier shall be braced and centered with casing spacers within the casing pipe to preclude possible flotation. Casing spacers shall be installed a maximum of eight (8) feet apart along the length of the carrier pipe within the casing pipe, within two (2) feet of each side of a pipe joint, and the rest evenly spaced. The height of the supports and runners combined shall be sufficient to keep the carrier pipe at least 0.75" from the casing pipe wall at all times. Manufacturer's recommendations may govern these requirements.
- B. At each end of the casing pipe, the carrier pipe shall be sealed with casing end seals. The end seals shall extend a minimum of 12 inches in each direction from the end of the casing pipe.
- C. Wood skids are not an acceptable method of supporting the carrier pipe.

02400-4
Casing Pipe

3.02 BORING AND JACKING

- A. The Contractor shall excavate his own pits, as he may deem necessary, and will set his grade which shall be checked by the Engineer. Permits, as required, will be furnished or obtained by the Owner, but shall be in the Contractor's hands before any excavating is commenced.

- B. The boring method shall consist of pushing the pipe into the earth with a boring auger rotating within the pipe to remove the spoil.
 - 1. The boring operation shall be progressed until the leading edge of the pipe has reached the receiving pit.
 - 2. The front of the pipe shall be provided with mechanical arrangements or devices that will positively prevent the auger from leading the pipe so that there will be no unsupported excavation ahead of the pipe.
 - 3. The auger and cutting head arrangement shall be removable from within the pipe in the event an obstruction is encountered. If the obstruction cannot be removed without excavation in advance of the pipe, the pipe shall be abandoned in place and immediately filled with grout or flowable fill concrete.
 - 4. The over-cut by the cutting head shall not exceed the outside diameter of the pipe by more than 2 inch. If voids should develop or if the bored hole diameter is greater than the outside diameter of the pipe by more than approximately 1 inch, grouting or other approved methods must be used to fill such voids.
 - 5. The face of the cutting head shall be arranged to provide a reasonable obstruction to the free flow of soft or poor material.
 - 6. Any method which does not have this boring arrangement will not be permitted. Contractor's boring arrangement plans and methods must be submitted to, and approved by, the Engineer.

- C. In the event an obstruction is encountered in boring which cannot be removed and it becomes necessary to withdraw the casing and commence elsewhere, the hole from which the casing is withdrawn shall be completely backfilled with flowable fill concrete.

- D. Insurance to be furnished by the Contractor to cover this type of work shall be adequate to meet the requirements of the Railroad and/or State or County Highway Departments.

3.03 CONTRACTOR'S RESPONSIBILITIES

- A. Obtain a copy of the highway or railroad encroachment permit from Owner before beginning construction.
- B. Attend a preconstruction meeting, if requested by the Owner, at the construction site with the Owner, Highway Inspector Engineer, and Contractor being present.

END OF SECTION

SECTION 02665
Water Mains and Accessories

PART 1 GENERAL

1.01 SCOPE

- A. This Section describes products to be incorporated into the water mains and requirements for the installation and use of these items. Furnish all products and perform all labor necessary to fulfill the requirements of these Specifications.
- B. General: Supply all products and perform all work in accordance with applicable American Society for Testing and Material (ASTM), American Water Works Association (AWWA), American National Standards Institute (ANSI), or other recognized standards. Latest revisions of all standards are applicable.

1.02 QUALIFICATIONS

If requested by the ENGINEER, submit evidence that manufacturers have consistently produced products of satisfactory quality and performance for a period of at least two years.

1.03 SUBMITTALS

Complete shop drawings and engineering data for all products shall be submitted to the ENGINEER in accordance with the requirements of Section 01340 of these Specifications.

1.04 TRANSPORTATION AND HANDLING

- A. Unloading: Furnish equipment and facilities for unloading, handling, distributing and storing pipe, fittings, valves and accessories. Make equipment available at all times for use in unloading. Do not drop or dump materials. Any materials dropped or dumped will be subject to rejection without additional justification. Pipe handled on skids shall not be rolled or skidded against the pipe on the ground.
- B. Handling: Handle pipe, fittings, valves and accessories carefully to prevent shock or damage. Handle pipe by rolling on skids, forklift, or front end loader. Do not

02665-2

Water Mains and Accessories

use material damaged in handling. Slings, hooks or pipe tongs shall be padded and used in such a manner as to prevent damage to the exterior coatings or internal lining of the pipe.

1.05 OWNER FURNISHED MATERIALS

- A. Submit with construction progress schedule, a schedule for required deliveries of Owner furnished Material.
- B. The Contractor shall coordinate material shipments with the Owner and the materials suppliers.
- C. Materials furnished by the Owner will be delivered by truck. Pipe, fittings, valves and other material to be furnished by the Owner shall be delivered to the Owner's storage yard or another site agreed upon by the Contractor and the Owner. This other site, if selected, is to be provided by the Contractor at no additional cost to the Owner.
- D. The Contractor shall maintain communication with the material suppliers, and the Owner as necessary, to keep informed as to scheduled shipment, and upon notice to the Contractor of the delivery of materials, the Contractor shall proceed without delay to unload such materials.
- E. Upon receipt of materials from the manufacturer, the Contractor shall make an inspection of such materials, checking and certifying the bill of lading, noting any discrepancies and obtaining a proper memorandum signed by the agent of the carrier for any shortage in the shipment, or for any damaged materials received. All bills of lading and any memorandum for shortage or damage of material in the shipment shall be promptly submitted to the Engineer. The Contractor shall be responsible for distribution of all materials as required to complete the Work. Materials furnished to the Contractor shall be in the custody of the Contractor from the time of receipt by the Contractor of such materials from the carrier until final acceptance of the completed Work. The Contractor shall be responsible for any loss of damage to materials furnished by the Owner.

1.06 STORAGE AND PROTECTION

- A. Store all pipe which cannot be distributed along the route. CONTRACTOR shall make arrangements for the use of suitable storage areas.
- B. Stored materials shall be kept safe from damage. The interior of all pipe, fittings and other appurtenances shall be kept free from dirt or foreign matter at all

times. Valves and hydrants shall be drained and stored in a manner that will protect them from damage by freezing.

- C. Pipe shall not be stacked higher than the limits recommended by the manufacturer. The bottom tier shall be kept off the ground on timbers, rails or concrete. Pipe in tiers shall be alternated: bell, plain end; bell, plain end. At least two rows of timbers shall be placed between tiers and chocks, affixed to each other in order to prevent movement. The timbers shall be large enough to prevent contact between the pipe in adjacent tiers.
- D. Stored mechanical and push-on joint gaskets shall be placed in a cool location out of direct sunlight. Gaskets shall not come in contact with petroleum products. Gaskets shall be used on a first-in, first-out basis.
- E. Mechanical-joint bolts shall be handled and stored in such a manner that will ensure proper use with respect to types and sizes.

1.07 QUALITY ASSURANCE

The manufacturer shall provide written certification to the ENGINEER that all products furnished comply with all applicable requirements of these Specifications.

PART 2 PRODUCTS

2.01 PIPING MATERIALS AND ACCESSORIES

- A. Ductile Iron Pipe (DIP)
 - 1. Ductile iron pipe shall be manufactured in accordance with AWWA C151 (latest edition). All pipe, except specials, shall be furnished in nominal lengths of 18 to 20 feet. Sizes will be as shown on the Drawings. All pipe shall have a minimum pressure rating as indicated in the following table, and corresponding minimum wall thickness, unless otherwise specified or shown on the Drawings:

Pipe Sizes (inches)	Pressure Class (psi)
4 - 12	350
14 - 18	250
20	250
24	200

02665-4

Water Mains and Accessories

30 - 54	250
60 - 64	200

2. Flanged pipe minimum wall thickness shall be equal to Special Class 53. Flanges shall be furnished by the pipe manufacturer.
3. Pipe and fittings shall be cement lined in accordance with AWWA C104 (latest edition). Pipe and fittings shall be furnished with a bituminous outside coating.
4. Fittings shall be ductile iron and shall conform to AWWA C110 or AWWA C153 (latest edition) with a minimum rated working pressure of 250 psi or as indicated on plans.
5. Joints
 - a. Unless shown or specified otherwise, joints shall be push-on or restrained joint type for pipe and standard mechanical, push-on or restrained joints for fittings. Push-on and mechanical joints shall conform to AWWA C111 (latest edition). Restrained joints for pipe and fittings shall be American "FLEX-RING" or "LOK-RING", Clow "SUPER-LOCK", or U.S. Pipe "TR FLEX". No field welding of restrained joint pipe will be permitted. No mega lug type restraints are allowed on 24" and 30" water line.
 - b. Restrained joint pipe (RJP) on supports shall have bolted joints and shall be specifically designed for clear spans of at least 36 feet.
 - c. Flanged joints shall meet the requirements of ANSI B16.1, Class 125.
6. Provide the appropriate gaskets for mechanical and flange joints. Gaskets for flange joints shall be made of 1/8-inch thick, cloth reinforced rubber; gaskets may be ring type or full face type.
7. Provide the necessary bolts for mechanical, restrained and flange connections. Bolts for flange connections shall be steel with American Regular unfinished square or hexagon heads. Nuts shall be steel with American Standard Regular hexagonal dimensions, all as specified in ANSI B17.2. All bolts and all nuts shall be threaded in accordance with ANSI B1.1,

02665-5

Water Mains and Accessories

Coarse Thread Series, Class 2A and 2B fit. Mechanical joint glands shall be ductile iron.

8. Acceptance will be on the basis of the ENGINEER'S inspection and the manufacturer's written certification that the pipe was manufactured and tested in accordance with the applicable standards.

B. Polyvinyl Chloride Pipe (PVC)

1. All PVC pipe shall have belled ends for push-on type jointing and shall conform to ASTM D 2241. The pipe shall have a Standard Dimension Ratio as indicated on the plans. Pipe shall be supplied in minimum lengths of 20 feet.
2. All fittings shall be of cast or ductile iron meeting the requirements of AWWA C110 or AWWA C153 (latest edition) with a minimum rated working pressure of 250 psi. Fittings shall be cement lined in accordance with AWWA C104. Fittings shall be furnished with a bituminous outside coating. Special adapters shall be provided as recommended by the manufacturer to adapt the PVC pipe to mechanical jointing with cast or ductile iron pipe, fittings, or valves.
3. Detection tape shall be provided over all PVC water mains.
4. Acceptance will be on the basis of the ENGINEER'S or OWNER'S inspection and the manufacturer's written certification that the pipe was manufactured and tested in accordance with the applicable standards, including the National Sanitation Foundation. Additionally, each piece of pipe shall be stamped "NSF Approved".

C. Polyvinyl Chloride Pipe (PVC) - **(C-900)**

1. All PVC pipe shall have belled ends for push-on type jointing and shall conform to AWWA C900, ductile iron pipe equivalent outside diameters. The pipe shall have a Dimension Ratio (DR) of **14** and shall be capable of withstanding a working pressure of **200** psi. Pipe shall be supplied in minimum lengths of 20 feet.
2. All fittings shall be of cast or ductile iron meeting the requirements of AWWA C110 or AWWA C153 with a minimum rated working pressure of **250** psi. Fittings shall be cement lined in accordance with AWWA C104.

02665-6

Water Mains and Accessories

Fittings shall be furnished with a bituminous outside coating. Special adapters shall be provided, as recommended by the manufacturer, to adapt the PVC pipe to mechanical jointing with cast or ductile iron pipe, fittings or valves.

3. Detection tape shall be provided over all PVC water mains.
4. Acceptance will be on the basis of the ENGINEER'S inspection and the manufacturer's written certification that the pipe was manufactured and tested in accordance with the applicable standards, including the National Sanitation Foundation. Additionally, each piece of pipe shall be stamped "NSF Approved".

D. Polyethylene Pipe and Fittings

1. The CONTRACTOR shall furnish and install high density polyethylene pipe meeting these Specifications at the locations indicated on the Plans and in other sections of these Specifications.
 - a. High Density polyethylene pipe shall be manufactured and tested in conformance to the requirements of the latest revision of the American Society for Testing and Materials designation ASTM D-3350 "Polyethylene Plastic Pipe and Fittings Materials".
 - b. High density Polyethylene pipe shall have a grade designation of PE 3406 and a cell classification designation of P 355434C.
 - c. High density polyethylene pipe shall be joined by means of butt fusion.
 - d. Fittings for high density polyethylene pipe shall be manufactured of the same materials as the pipe. Unless otherwise indicated, all fittings shall be joined to the pipe by butt fusion techniques.

2.02 VALVES

A. Gate Valves (GV)

1. 3-Inches in Diameter and Smaller: Gate valves shall be bronze, heavy duty, rising stem, wedge type with screwed or union bonnet. Valve ends shall be threaded or solder type as appropriate. Valves shall have a minimum 200 psi working pressure for water (125 psi working pressure for steam). Valves

02665-7

Water Mains and Accessories

shall be made in the U.S.A. Gate valves shall be equal to Crane No. 428 (threaded) or Crane No. 1334 (solder end).

2. 4-Inches Through 12-Inches in Diameter: Gate valves 4-inches through 12-inches shall be resilient wedge type conforming to the requirements of AWWA C509 rated for 200 psi working pressure.
 - a. Valves shall be provided with two O-ring stem seals with one O-ring located above and one O-ring below the stem collar. The area between the O-rings shall be filled with lubricant to provide lubrication to the thrust collar bearing surfaces each time the valve is operated. At least one anti-friction washer shall be utilized to further minimize operating torque. All seals between valve parts, such as body and bonnet, bonnet and bonnet cover, shall be flat gaskets or O-rings.
 - b. The valve gate shall be made of cast iron having a vulcanized, synthetic rubber coating, or a seat ring attached to the disc with retaining screws. Sliding of the rubber on the seating surfaces to compress the rubber will not be allowed. The design shall be such that compression-set of the rubber shall not affect the ability of the valve to seal when pressure is applied to either side of the gate. The sealing mechanism shall provide zero leakage at the water working pressure when installed with the line flow in either direction.
 - c. All internal ferrous surfaces shall be coated with epoxy to a minimum thickness of 4 mils. The epoxy shall be non-toxic, impart no taste to the water and shall conform to AWWA C550, latest revision.
 - d. Gate valves 4 through 12-inches shall be manufactured by American-Darling, Mueller or M & H Valve.

2.03 FIRE HYDRANTS (FH)

- A. All fire hydrants shall conform to the requirements of AWWA C502 for 250 psi working pressure. Hydrants shall be the compression type, closing with line pressure. The valve opening shall not be less than [5-1/4-inches].
- B. In the event of a traffic accident, the hydrant barrel shall break away from the standpipe at a point above grade and in a manner which will prevent damage to

02665-8

Water Mains and Accessories

- the barrel and stem, preclude opening of the valve, and permit rapid and inexpensive restoration without digging or cutting off the water.
- C. The means for attaching the barrel to the standpipe shall permit facing the hydrant a minimum of eight different directions.
 - D. Hydrants shall be fully bronze mounted with all working parts of bronze. Valve seat ring shall be bronze and shall screw into a bronze retainer.
 - E. All working parts, including the seat ring shall be removable through the top without disturbing the barrel of the hydrant.
 - F. The operating nut shall match those on the existing hydrants. The operating threads shall be totally enclosed in an operating chamber, separated from the hydrant barrel by a rubber O-ring stem seal and lubricated by a grease or an oil reservoir.
 - G. Hydrant shall be a non-freezing design and be provided with a simple, positive, and automatic drain which shall be fully closed whenever the main valve is opened.
 - H. Hose and pumper connections shall be breech-locked, pinned, or threaded and pinned to seal them into the hydrant barrel. Each hydrant shall have two 2-1/2-inch hose connections and one 4-1/2-inch pumper connection, all with National Standard threads and each equipped with cap and non-kinking chain.
 - I. Hydrants shall be furnished with a mechanical joint connection to the spigot of the 6-inch hydrant lead.
 - J. Minimum depth of bury shall be 4.5 feet. Provide extension section where necessary for proper vertical installation and in accordance with manufacturer's recommendations.
 - K. All outside surfaces of the barrel above grade shall be painted with enamel equal to Koppers Glamortex 501 in a color to be selected by the Owner.
 - L. Hydrants shall be traffic model and shall be Mueller Super Centurion or approved equal.

2.04 VALVE BOXES (VB) AND EXTENSION STEMS

- A. All valves shall be equipped with valve boxes. The valve boxes shall be cast iron two-piece screw type with drop covers. Valve boxes shall have a 5.25-inch inside diameter. Valve box covers shall weigh a minimum of 13 pounds. The valve boxes shall be adjustable to 6-inches up or down from the nominal required cover over the pipe. Valve boxes shall be of sufficient length that bottom flange of the lower belled portion of the box is below the valve operating nut. Ductile or cast iron extensions shall be provided as necessary. Covers shall have "WATER VALVE" or "WATER" cast into them. Valve boxes shall be manufactured in the United States.
- B. All valves shall be furnished with extension stems, as necessary, to bring the operating nut to within 30-inches of the top of the valve box. Connection to the valve shall be with a wrench nut coupling and a set screw to secure the coupling to the valve's operating nut. The coupling and square wrench nut shall be welded to the extension stem. Extension stems shall be equal to Mueller A-26441 or M & H Valve Style 3801.
- C. All Valve Boxes shall be installed with Concrete Collars as Indicated on the Detail Sheet.

2.05 VALVE MARKERS (VM)

The CONTRACTOR shall provide a concrete valve marker as detailed on the Drawings for each valve installed. Valve markers shall be stamped "Water".

2.06 TAPPING SLEEVES AND VALVES (TS&V)

Tapping sleeves shall be stainless steel of the split-sleeve, mechanical joint type. The CONTRACTOR shall be responsible for determining the outside diameter of the pipe to be connected to prior to ordering the sleeve. Valves shall be gate valves furnished in accordance with the specifications shown above, with flanged connection to the tapping sleeve and mechanical joint connection to the branch pipe. The tapping sleeve and valve shall be supplied by the valve manufacturer. Tapping sleeves shall be equal to American-Darling, Mueller or M & H Valve.

02665-10

Water Mains and Accessories

2.07 TAPPING SADDLES

Tapping saddles shall be brass body type with O-ring gasket. Tapping saddles shall be equal to Mueller Series H-134 Service Clamp.

2.08 CORPORATION COCKS AND CURB STOPS

Corporation cocks and curb stops shall be ground key type, shall be made of bronze conforming to ASTM B 61 or B 62, and shall be suitable for the working pressure of the system. Ends shall be suitable for flared tube compression type joint. Threaded ends for inlet and outlet of corporation cocks shall conform to AWWA C800; coupling nut for connection to flared copper tubing shall conform to ANSI B16.26. Corporation cocks and curb stops shall be manufactured by Mueller or Ford or approved equal.

2.10 METER SETTERS

The meter setter shall be a tandem coppersetter as shown on the standard detail drawings with 3/4" double purpose ends and be 15" high with padlock wing. It shall be all purpose, designed for 5/8" x 3/4" meter and be of sufficient height to raise meters above the bottom of the meter box. The meter setter shall be Ford, or equal. Meter setters shall have an inverted key inlet valve.

Setters shall be installed so that the meters are centered in the meter box.

The water service line shall be extended a minimum of 18" beyond the meter box on the customer end. The end of the extension shall be capped or plugged to prevent entry of foreign material until the connection is made.

2.11 WATER METERS

Water meter shall be cold water displacement type meeting all requirement of AWWA C700-77. The meter sizes shall be 5/8-inch x 3/4-inch meters for 3/4" service rated at a flow of 20 gpm and 1" meters for 1" service rated at a flow of 50 gpm. Meters shall be of frost-proof design and be rotating disk type. The meters shall be equipped with a straight-reading register recording in U.S. Gallons hermetically sealed to prevent fogging and with a removable corrosion resistant strainer screen between the outer case and measuring chamber. Register shall be equipped with a device to afford capability for accurately testing each meter according to AWWA Standards. The body case shall have the manufacturer's serial number imprinted thereon and have raised markings to indicate the direction of flow.

02665-11

Water Mains and Accessories

2.12 CONCRETE

Concrete shall have a compressive strength of not less than 3000 psi, with not less than 5.5 bags of cement per cubic yard and a slump between 3 and 5-inches. For job mixed concrete, submit the concrete mix design for approval by the Engineer. Ready-mixed concrete shall be mixed and transported in accordance with ASTM C 94. Reinforcing steel shall conform to the requirements of ASTM A 615, Grade 60.

PART 3 EXECUTION

3.01 EXISTING UTILITIES AND OBSTRUCTIONS

- A. The Drawings indicate utilities or obstructions that are known to exist according to the best information available to the OWNER. The CONTRACTOR shall call the agencies or departments that own and/or operate utilities in the vicinity of the construction work site at least 72 hours (three business days) prior to construction to verify the location of the existing utilities.
- B. Existing Utility Location: The following steps shall be exercised to avoid interruption of existing utility service.
 1. Provide the required notice to the utility owners and allow them to locate their facilities. Field utility locations are valid for only 10 days after original notice. The CONTRACTOR shall ensure, at the time of any excavation, that a valid utility location exists at the point of excavation.
 2. Expose the facility, for a distance of at least 200 feet in advance of pipeline construction, to verify its true location and grade. Repair, or have repaired, any damage to utilities resulting from locating or exposing their true location.
 3. Avoid utility damage and interruption by protection with means or methods recommended by the utility owner.
 4. Maintain a log identifying when phone calls were made, who was called, area for which utility relocation was requested and work order number issued, if any. The CONTRACTOR shall provide the ENGINEER an updated copy of the log bi-weekly, or more frequently if required.

02665-12

Water Mains and Accessories

C. Conflict with Existing Utilities

1. Horizontal Conflict: Horizontal conflict shall be defined as when the actual horizontal separation between a utility, main, or service and the proposed water main does not permit safe installation of the water main by the use of sheeting, shoring, tying-back, supporting, or temporarily suspending service of the parallel or crossing facility. The CONTRACTOR may change the proposed alignment of the water main to avoid horizontal conflicts if the new alignment remains within the available right-of-way or easement, complies with regulatory agency requirements and after a written request to and subsequent approval by the ENGINEER or OWNER. Where such relocation of the water main is denied by the ENGINEER or OWNER, the CONTRACTOR shall arrange to have the utility, main, or service relocated.
2. Vertical Conflict: Vertical conflict shall be defined as when the actual vertical separation between a utility, main, or service and the proposed water main does not permit the crossing without immediate or potential future damage to the utility, main, service, or the water main. The CONTRACTOR may change the proposed grade of the water main to avoid vertical conflicts if the changed grade maintains adequate cover and complies with regulatory agencies requirements after written request to and subsequent approval by the ENGINEER or OWNER. Where such relocation of the water main is denied by the ENGINEER or OWNER, the CONTRACTOR shall arrange to have the utility, main, or service relocated.

D. Electronic Locator: Have available at all times an electronic pipe locator and a magnetic locator, in good working order, to aid in locating existing pipe lines or other obstructions.

E. Water and Sewer Separation

1. Water mains should maintain a minimum 10 foot edge-to-edge separation from sewer lines, whether gravity or pressure. If the main cannot be installed in the prescribed easement or right-of-way and provide the 10 foot separation, the separation may be reduced, provided the bottom of the water main is a minimum of 18-inches above the top of the sewer. Should neither of these two separation criteria be possible, the water main shall be installed below the sewer with a minimum vertical separation of 18-inches.
2. The water main, when installed below the sewer, shall be encased in concrete with a minimum 6-inch concrete depth to the first joint in each

02665-13

Water Mains and Accessories

direction. Where water mains cross the sewer, the pipe joint adjacent to the pipe crossing the sewer shall be cut to provide maximum separation of the pipe joints from the sewer.

3. No water main shall pass through, or come in contact with, any part of a sanitary sewer manhole.

3.02 CONSTRUCTION ALONG HIGHWAYS, STREETS AND ROADWAYS

- A. Install pipe lines and appurtenances along highways, streets and roadways in accordance with the applicable regulations of, and permits issued by, the Department of Transportation, Lincoln County and the City of Stanford with reference to construction operations, safety, traffic control, road maintenance and repair.
- B. Traffic Control
 1. The CONTRACTOR shall provide, erect and maintain all necessary barricades, suitable and sufficient lights and other traffic control devices; provide qualified flagmen where necessary to direct traffic; take all necessary precautions for the protection of the work and the safety of the public.
 2. Construction traffic control devices and their installation shall be in accordance with the current Manual On Uniform Traffic Control Devices for Streets and Highways and the Department of Highways Specifications, latest edition.
 3. Placement and removal of construction traffic control devices shall be coordinated with the Department of Transportation, Lincoln County, and the Stanford Water Commission a minimum of 48 hours in advance of the activity.
 4. Placement of construction traffic control devices shall be scheduled ahead of associated construction activities. Construction time in street right-of-way shall be conducted to minimize the length of time traffic is disrupted. Construction traffic control devices shall be removed immediately following their useful purpose. Traffic control devices used intermittently, such as "Flagmen Ahead", shall be removed and replaced when needed.

02665-14

Water Mains and Accessories

5. Existing traffic control devices within the construction work zone shall be protected from damage. Traffic control devices requiring temporary relocation shall be located as near as possible to their original vertical and horizontal locations. Original locations shall be measured from reference points and recorded in a log prior to relocation. Temporary locations shall provide the same visibility to affected traffic as the original location. Relocated traffic control devices shall be reinstalled in their original locations as soon as practical following construction.
6. Construction traffic control devices shall be maintained in good repair and shall be clean and visible to affected traffic for daytime and nighttime operation. Traffic control devices affected by the construction work zone shall be inspected daily.
7. Construction warning signs shall be black legend on an orange background. Regulatory signs shall be black legend on a white background. Construction sign panels shall meet the minimum reflective requirements of the Department of Transportation, Lincoln County, and the City of Stanford. Sign panels shall be of durable materials capable of maintaining their color, reflective character and legibility during the period of construction.
8. Channelization devices shall be positioned preceding an obstruction at a taper length as required by the current Manual On Uniform Traffic Control Devices for Streets and Highways, as appropriate for the speed limit at that location. Channelization devices shall be patrolled to insure that they are maintained in the proper position throughout their period of use.

C. Construction Operations

1. Perform all work along highways, streets and roadways to minimize interference with traffic.
2. Stripping: Where the pipe line is laid along road right-of-way, strip and stockpile all sod, topsoil and other material suitable for right-of-way restoration.
3. Trenching, Laying and Backfilling: Do not open the trench any further ahead of pipe laying operations than is necessary. Backfill and remove excess material immediately behind laying operations. Complete excavation and backfill for any portion of the trench in the same day.

02665-15

Water Mains and Accessories

4. Shaping: Reshape damaged slopes, side ditches, and ditch lines immediately after completing backfilling operations. Replace topsoil, sod and any other materials removed from shoulders.
 5. Construction operations shall be limited to 400 feet along areas within KYDOT jurisdiction, including clean-up and utility exploration.
- D. Excavated Materials: Do not place excavated material along highways, streets and roadways in a manner which obstructs traffic. Sweep all scattered excavated material off of the pavement in a timely manner.
- E. Drainage Structures: Keep all side ditches, culverts, cross drains, and other drainage structures clear of excavated material. Care shall be taken to provide positive drainage to avoid ponding or concentration of runoff.
1. The CONTRACTOR shall make provisions for handling all flows in existing creeks, ditches, sewers and trenches by pipes, flumes or other approved methods at all times when his operations would, in any way, interfere with the natural functioning of said creeks, ditches, sewers and drains. The CONTRACTOR shall at all times during construction provide and maintain sufficient equipment for the disposal of all water which enters the excavation, both in open cut trenches and in tunnels, to render such excavation firm and dry, until the structures to be built thereon are completed.
- F. Landscaping Features: Landscaping features shall include, but are not necessarily limited to: fences; property corners; cultivated trees and shrubbery; manmade improvements; subdivision and other signs within the right-of-way and easement. The CONTRACTOR shall take extreme care in moving landscape features and promptly re-establishing these features.
- G. Maintaining Highways, Streets, Roadways and Driveways
1. Maintain streets, highways, roadways and driveways in suitable condition for movement of traffic until completion and final acceptance of the Work. All excavation shall be conducted in a manner to the last interruption to traffic.
 2. During the time period between pavement removal and completing permanent pavement replacement, maintain highways, streets and roadways by the use of steel running plates. Running plate edges shall have

02665-16

Water Mains and Accessories

asphalt placed around their periphery to minimize vehicular impact. The backfill above the pipe shall be compacted as specified elsewhere up to the existing pavement surface to provide support for the steel running plates.

3. Furnish a road grader or front-end loader for maintaining highways, streets, and roadways. The grader or front-end loader shall be available at all times.
4. Immediately repair all driveways that are cut or damaged. Maintain them in a suitable condition for use until completion and final acceptance of the Work. Driveways and other private and public access routes shall not be kept blocked or closed by the CONTRACTOR for more than a reasonable period of time without prior written approval from the property owner or controlling authority.
5. Maintenance of all traffic shall be in accordance with any requirements of the local road department(s) and/or the Kentucky Department of Transportation. It is the responsibility of the CONTRACTOR to coordinate all work with and notify the above-named agencies, and to provide all necessary signs, barricades, lights, flagmen, and other items for maintenance of traffic.

Public travel shall be maintained, unrestricted, wherever and whenever possible. Detours shall be provided when so directed by the appropriate agency. Adequate precautions shall be taken to provide for the safety of both vehicular and pedestrian traffic. Emergency vehicles shall be provided access to construction area at all times.

Unless specifically directed otherwise by the ENGINEER, not more than five hundred (500') feet of trench shall be opened ahead of the pipe laying, and not more than five hundred (500') feet of open ditch shall be left behind the pipe laying. All barricades, lanterns, watchmen, and other such signs and signals as may be necessary to warn the public of the dangers in connection with open trenches, excavations and other obstructions, shall be provided by and at the expense of the CONTRACTOR.

When so required, or when directed by the ENGINEER, only one-half (1/2) of the street crossing and road crossings shall be excavated before placing temporary bridges over the side excavated for the convenience of the traveling public.

All backfilled ditches shall be maintained in such manner that they will offer no hazard to the traveling public and the property owners abutting the

02665-17

Water Mains and Accessories

improvements shall be taken into consideration. All public or private drives shall be promptly backfilled or bridges at the direction of the ENGINEER. Excavated materials shall be disposed of so as to cause the least interference, and in every case the deposition of excavated materials shall be satisfactory to the ENGINEER.

H. Property Protection

1. Extreme care shall be taken to protect trees, fences, poles, crops and all other property from damage unless their removal is authorized by the ENGINEER. Any damaged property shall be restored to as good or better than original condition and shall meet with the approval of the ENGINEER and OWNER.
2. The CONTRACTOR has the right to fully utilize the easement unless specifically stated otherwise on the plans or by the ENGINEER. If any irreplaceable trees, fences, poles or crops, such as tobacco, corn, soy beans and such (excluding pasture land), occur on the easement the CONTRACTOR shall obtain the ENGINEER's and OWNER's approval prior to removing or otherwise causing damage to any of these items.
3. Beyond the limits of the easement the CONTRACTOR shall be responsible for any damage caused by his operations and/or his personnel.

3.03 PIPE DISTRIBUTION

- A. Pipe shall be distributed and placed in such a manner that will not interfere with traffic.
- B. No pipe shall be strung further along the route than 1000 feet beyond the area in which the CONTRACTOR is actually working without written permission from the OWNER.
- C. No street or roadway may be closed for unloading of pipe without first obtaining permission from the proper authorities. The CONTRACTOR shall furnish and maintain proper warning signs and obstruction lights for the protection of traffic along highways, streets and roadways upon which pipe is distributed.
- D. No distributed pipe shall be placed inside drainage ditches.

02665-18

Water Mains and Accessories

- E. Distributed pipe shall be placed as far as possible from the roadway pavement, but no closer than five feet from the roadway pavement, as measured edge-to-edge.

3.04 LOCATION AND GRADE

- A. The Drawings show the alignment of the water main and the location of valves, hydrants and other appurtenances.
- B. Construction Staking
 - 1. The base lines for locating the principal components of the work and a bench marks adjacent to the work are shown on the Drawings if Available. Base lines shall be defined as the line to which the location of the water main is referenced, i.e., edge of pavement, road centerline, property line, right-of-way or survey line. The CONTRACTOR shall be responsible for performing all survey work required for constructing the water main, including the establishment of base lines and any detail surveys needed for construction. This work shall include the staking out of permanent and temporary easements to insure that the CONTRACTOR is not deviating from the designated easements.
 - 2. The level of detail of survey required shall be that which the correct location of the water main can be established for construction and verified by the ENGINEER or OWNER. Where the location of components of the water main, e.g. tunnels and fittings, are not dimensioned, the establishment on the location of these components shall be based upon scaling these locations from the Drawings with relation to readily identifiable land marks, e.g., survey reference points, power poles, manholes, etc.
- C. Reference Points
 - 1. The CONTRACTOR shall take all precautions necessary, which includes, but is not necessarily limited to, installing reference points, in order to protect and preserve the centerline or baseline established by the ENGINEER.
 - 2. Reference points shall be placed, at or no more than three feet, from the outside of the construction easement or right-of-way. The location of the reference points shall be recorded in a log with a copy provided to the ENGINEER and OWNER for use, prior to verifying reference point locations.

02665-19

Water Mains and Accessories

Distances between reference points and the manhole centerlines shall be accurately measured to 0.01 foot.

3. The CONTRACTOR shall give the ENGINEER reasonable notice that reference points are set. The reference point locations must be verified by the ENGINEER prior to commencing clearing and grubbing operations.
- D. After the CONTRACTOR locates and marks the water main centerline or baseline, the CONTRACTOR shall perform clearing and grubbing.
- E. Construction shall begin at a connection location and proceed without interruption. Multiple construction sites shall not be permitted without written authorization from the ENGINEER for each site.
- F. The CONTRACTOR shall be responsible for any damage done to reference points, base lines, center lines and temporary bench marks, and shall be responsible for the cost of re-establishment of reference points, base lines, center lines and temporary bench marks as a result of the operations.

3.05 LAYING AND JOINTING PIPE AND ACCESSORIES

- A. Lay all pipe and fittings to accurately conform to the lines and grades established by the ENGINEER.
- B. Pipe Installation
 1. Proper implements, tools and facilities shall be provided for the safe performance of the Work. All pipe, fittings, valves and hydrants shall be lowered carefully into the trench by means of slings, ropes or other suitable tools or equipment in such a manner as to prevent damage to water main materials and protective coatings and linings. Under no circumstances shall water main materials be dropped or dumped into the trench.
 2. All pipe, fittings, valves, hydrants and other appurtenances shall be examined carefully for damage and other defects immediately before installation. Defective materials shall be marked and held for inspection by the ENGINEER, who may prescribe corrective repairs or reject the materials.
 3. All lumps, blisters and excess coating shall be removed from the socket and plain ends of each pipe, and the outside of the plain end and the inside of the bell shall be wiped clean and dry and free from dirt, sand, grit or any

02665-20

Water Mains and Accessories

foreign materials before the pipe is laid. No pipe containing dirt shall be laid.

4. Foreign material shall be prevented from entering the pipe while it is being placed in the trench. No debris, tools, clothing or other materials shall be placed in the pipe at any time.
5. As each length of pipe is placed in the trench, the joint shall be assembled and the pipe brought to correct line and grade. The pipe shall be secured in place with approved backfill material.
6. It is not mandatory to lay pipe with the bells facing the direction in which work is progressing.
7. Applying pressure to the top of the pipe, such as with a backhoe bucket, to lower the pipe to the proper elevation or grade, shall not be permitted.
8. Detection tape shall be buried 4 to 10-inches deep. Should detection tape need to be installed deeper, the CONTRACTOR shall provide 3-inch wide tape. In no case shall detection tape be buried greater than 20-inches from the finish grade surface.

C. Alignment and Gradient

1. Lay pipe straight in alignment and gradient or follow true curves as nearly as practicable. Do not deflect any joint more than the maximum deflection recommended by the manufacturer.
2. Maintain a transit, level and accessories on the job to lay out angles and ensure that deflection allowances are not exceeded.

- D. Expediting of Work: Excavate, lay the pipe, and backfill as closely together as possible. Do not leave unjointed pipe in the trench overnight. Backfill and compact the trench as soon as possible after laying and jointing is completed. Cover the exposed end of the installed pipe each day at the close of work and at all other times when work is not in progress. If necessary to backfill over the end of an uncompleted pipe or accessory, close the end with a suitable plug, either push-on, mechanical joint, restrained joint or as approved by the ENGINEER.

02665-21

Water Mains and Accessories

-
- E. Joint Assembly
1. Push-on, mechanical, flange and restrained type joints shall be assembled in accordance with the manufacturer's recommendations.
 2. The CONTRACTOR shall inspect each pipe joint within 200 feet on either side of main line valves to insure 100 percent seating of the pipe spigot, except as noted otherwise.
 3. Each restrained joint shall be inspected by the CONTRACTOR to ensure that it has been "homed" 100 percent.
 4. The CONTRACTOR shall internally inspect each pipe joint to insure proper assembly for pipe 24-inches in diameter and larger after the pipe has been brought to final alignment.
- F. Cutting Pipe: Cut ductile iron pipe using an abrasive wheel saw. Cut PVC pipe using a suitable saw; remove all burrs and smooth the end before jointing. The CONTRACTOR shall cut the pipe and bevel the end, as necessary, to provide the correct length of pipe necessary for installing the fittings, valves, accessories and closure pieces in the correct location. Only push-on or mechanical joint pipe shall be cut.
- G. Polyethylene Encasement: Installation shall be in accordance with AWWA C105 and the manufacturer's instructions. All ends shall be securely closed with tape and all damaged areas shall be completely repaired to the satisfaction of the Engineer.
- H. Valve and Fitting Installation
1. Prior to installation, valves shall be inspected for direction of opening, number of turns to open, freedom of operation, tightness of pressure-containing bolting and test plugs, cleanliness of valve ports and especially seating surfaces, handling damage and cracks. Defective valves shall be corrected or held for inspection by the ENGINEER. Valves shall be closed before being installed.
 2. Valves, fittings, plugs and caps shall be set and joined to the pipe in the manner specified in this Section for cleaning, laying and joining pipe, except that 12-inch and larger valves shall be provided with special support, such as treated timbers, crushed stone, concrete pads or a sufficiently tamped

02665-22

Water Mains and Accessories

trench bottom so that the pipe will not be required to support the weight of the valve. Valves shall be installed in the closed position.

3. A valve box shall be provided on each underground valve. They shall be carefully set, centered exactly over the operating nut and truly plumbed. The valve box shall not transmit shock or stress to the valve. The bottom flange of the lower belled portion of the box shall be placed below the valve operating nut. This flange shall be set on brick, so arranged that the weight of the valve box and superimposed loads will bear on the base and not on the valve or pipe. Extension stems shall be installed where depth of bury places the operating nut in excess of 30-inches beneath finished grade so as to set the top of the operating nut 30-inches below finished grade. The valve box cover shall be flush with the surface of the finished area or such other level as directed by the ENGINEER.
 4. In no case shall valves be used to bring misaligned pipe into alignment during installation. Pipe shall be supported in such a manner as to prevent stress on the valve.
 5. A valve marker shall be provided for each underground valve. Unless otherwise detailed on the Drawings or directed by the ENGINEER, valve markers shall be installed 6-inches inside the right-of-way or easement.
- I. Hydrant Installation
1. Prior to installation, inspect all hydrants for direction of opening, nozzle threading, operating nut and cap nut dimensions, tightness of pressure-containing bolting, cleanliness of inlet elbow, handling damage and cracks. Defective hydrants shall be corrected or held for inspection by the ENGINEER.
 2. All hydrants shall stand plumb and shall have their nozzles parallel with or at right angles to the roadway, with pumper nozzle facing the roadway, except that hydrants having two-hose nozzles 90 degrees apart shall be set with each nozzle facing the roadway at an angle of 45 degrees.
 3. Hydrants shall be set to the established grade, with the centerline of the lowest nozzle at least 12-inches above the ground or as directed by the ENGINEER.
 4. Each hydrant shall be connected to the main with a 6-inch branch controlled by an independent 6-inch valve. When a hydrant is set in soil

that is pervious, drainage shall be provided at the base of the hydrant by placing coarse gravel or crushed stone mixed with coarse sand from the bottom of the trench to at least 6-inches above the drain port opening in the hydrant to a distance of 12-inches around the elbow.

5. When a hydrant is set in clay or other impervious soil, a drainage pit 2 x 2 x 2 feet shall be excavated below each hydrant and filled with coarse gravel or crushed stone mixed with coarse sand under and around the elbow of the hydrant and to a level of 6-inches above the drain port.
6. Hydrants shall be located as shown on the Drawings or as directed by the ENGINEER. In the case of hydrants that are intended to fail at the ground-line joint upon vehicle impact, specific care must be taken to provide adequate soil resistance to avoid transmitting shock moment to the lower barrel and inlet connection. In loose or poor load bearing soil, this may be accomplished by pouring a concrete collar approximately 6-inches thick to a diameter of 24-inches at or near the ground line around the hydrant barrel.

3.06 CONNECTIONS TO WATER MAINS

- A. Make connections to existing pipe lines with tapping sleeves and valves, unless specifically shown otherwise on the Drawings.
- B. Location: Before laying pipe, locate the points of connection to existing water mains and uncover as necessary for the ENGINEER or OWNER to confirm the nature of the connection to be made.
- C. Interruption of Services: Make connections to existing water mains only when system operations permit. Operate existing valves only with the specific authorization and direct supervision of the Owner.
- D. Tapping Saddles and Tapping Sleeves
 1. Holes in the new pipe shall be machine cut, either in the field or at the factory. No torch cutting of holes shall be permitted.
 2. Prior to attaching the saddle or sleeve, the pipe shall be thoroughly cleaned, utilizing a brush and rag, as required.
 3. Before performing field machine cut, the watertightness of the saddle or sleeve assembly shall be pressure tested. The interior of the assembly shall

02665-24

Water Mains and Accessories

be filled with water. An air compressor shall be attached, which will induce a test pressure as specified in this Section. No leakage shall be permitted for a period of five minutes.

4. After attaching the saddle or sleeve to an existing main, but prior to making the tap, the interior of the assembly shall be disinfected. All surfaces to be exposed to potable water shall be swabbed or sprayed with a one percent hypochlorite solution.
- E. Connections Using Solid Sleeves: Where connections are shown on the Drawings using solid sleeves, the CONTRACTOR shall furnish materials and labor necessary to make the connection to the existing pipe line.
- F. Connections Using Couplings: Where connections are shown on the Drawings using couplings, the CONTRACTOR shall furnish materials and labor necessary to make the connection to the existing pipe line, including all necessary cutting, plugging and backfill.

3.07 THRUST RESTRAINT

- A. Provide restraint at all points where hydraulic thrust may develop.
- B. Concrete Blocking
 1. Provide concrete blocking for all bends, tees, valves, and other points where thrust may develop, except where other exclusive means of thrust restraint are specifically shown on the Drawings.
 2. Concrete shall be as specified in this Section.
 3. Form and pour concrete blocking at fittings as shown on the Drawings and as directed by the ENGINEER. Pour blocking against undisturbed earth. Increase dimensions when required by over excavation.

3.08 INSPECTION AND TESTING

- A. Pressure and Leakage Test
 1. All sections of the water main subject to internal pressure shall be pressure tested in accordance with AWWA C600. A section of main will be considered ready for testing after completion of all thrust restraint and backfilling.

02665-25

Water Mains and Accessories

2. Each segment of water main between main valves shall be tested individually. At no time shall the segment being tested exceed 3,500 feet without prior approval of the ENGINEER.
3. Test Preparation
 - a. For water mains less than 24-inches in diameter, flush sections thoroughly at flow velocities, greater than 2.5 feet per second, adequate to remove debris from pipe and valve seats. For water mains 24-inches in diameter and larger, the main shall be carefully swept clean, and mopped if directed by the ENGINEER. Partially open valves to allow the water to flush the valve seat.
 - b. Partially operate valves and hydrants to clean out seats.
 - c. Provide temporary blocking, bulkheads, flanges and plugs as necessary, to assure all new pipe, valves and appurtenances will be pressure tested.
 - d. Before applying test pressure, air shall be completely expelled from the pipeline and all appurtenances. Insert corporation cocks at highpoints to expel air as main is filled with water as necessary to supplement automatic air valves. Corporation stops shall be constructed as detailed on the Drawings with a meter box.
 - e. Fill pipeline slowly with water. Provide a suitable pump with an accurate water meter to pump the line to the specified pressure.
 - f. The differential pressure across a valve or hydrant shall equal the maximum possible, but not exceed the rated working pressure. Where necessary, provide temporary backpressure to meet the differential pressure restrictions.
 - g. Valves shall not be operated in either the opening or closing direction at differential pressures above the rated pressure.
4. Test Pressure: Test the pipeline at 50 psi above the rated working pressure of the pipe, measured at the lowest point, for at least two hours. Maintain the test pressure within 5 psi of the specified test pressure for the test duration. Should the pressure drop more than 5 psi at any time during the test period, the pressure shall be restored to the specified test pressure. Provide an accurate pressure gage with graduation not greater than 5 psi.

02665-26
Water Mains and Accessories

5. Leakage

- a. Leakage shall be defined as the sum of the quantity of water that must be pumped into the test section, to maintain pressure within 5 psi of the specified test pressure for the test duration plus water required to return line to test pressure at the end of the test. Leakage shall be the total cumulative amount measured on a water meter.
- b. The OWNER assumes no responsibility for leakage occurring through existing valves.

6. Test Results: No test section shall be accepted if the leakage exceeds the limits determined by the following formula:

$$L = \frac{SD(P)^{1/2}}{133,200}$$

- Where:
- L = allowable leakage, in gallons per hour
 - S = length of pipe tested, in feet
 - D = nominal diameter of the pipe, in inches
 - P = average test pressure during the leakage test, in pounds per square inch (gauge)

As determined under Section 4 of AWWA C600.

If the water main section being tested contains lengths of various pipe diameters, the allowable leakage shall be the sum of the computed leakage for each diameter. The leakage test shall be repeated until the test section is accepted. All visible leaks shall be repaired regardless of leakage test results.

7. Completion: After a pipeline section has been accepted, relieve test pressure. Record type, size and location of all outlets on record drawings.

3.09 DISINFECTING PIPELINE

- A. After successfully pressure testing each pipeline section, disinfect in accordance with AWWA C651 for the continuous-feed method and these Specifications.
- B. Specialty Contractor: Disinfection shall be performed by an approved specialty contractor. Before disinfection is performed, the CONTRACTOR shall submit a written procedure for approval before being permitted to proceed with the

02665-27

Water Mains and Accessories

disinfection. This plan shall also include the steps to be taken for the neutralization of the chlorinated water.

C. Chlorination

1. Apply chlorine solution to achieve a concentration of at least 50 milligrams per liter free chlorine in new line. Retain chlorinated water for 24 hours.
2. Chlorine concentration shall be recorded at every outlet along the line at the beginning and end of the 24 hour period.
3. After 24 hours, all samples of water shall contain at least 25 milligrams per liter free chlorine. Re-chlorinate if required results are not obtained on all samples.

D. Disposal of Chlorinated Water: Reduce chlorine residual of disinfection water to less than one milligram per liter if discharged directly to a body of water or to less than two milligrams per liter if discharged onto the ground prior to disposal. Treat water with sulfur dioxide or other reducing chemicals to neutralize chlorine residual. Flush all lines until residual is equal to existing system.

E. Bacteriological Testing: After final flushing and before the main is placed into service, the CONTRACTOR shall assist the OWNER in collecting samples from the line to have tested for bacteriological quality. Testing shall be performed by the OWNER at a laboratory certified by the State of Kentucky. Re-chlorinate lines until the required results are obtained.

3.10 PROTECTION AND RESTORATION OF WORK AREA

A. General: Return all items and all areas disturbed, directly or indirectly by work under these Specifications, to their original condition or better, as quickly as possible after work is started.

1. The CONTRACTOR shall plan, coordinate, and prosecute the work such that disruption to personal property and business is held to a practical minimum.
2. All construction areas abutting lawns and yards of residential or commercial property shall be restored promptly. Backfilling of underground facilities, ditches, and disturbed areas shall be accomplished on a daily basis as work is completed. Finishing, dressing, and grassing shall be accomplished

02665-28

Water Mains and Accessories

- immediately thereafter, as a continuous operation within each area being constructed and with emphasis placed on completing each individual yard or business frontage. Care shall be taken to provide positive drainage to avoid ponding or concentration of runoff.
3. Handwork, including raking and smoothing, shall be required to ensure that the removal of roots, sticks, rocks, and other debris is removed in order to provide a neat and pleasing appearance.
 4. The Department of Transportation's engineer shall be authorized to stop all work by the CONTRACTOR when restoration and cleanup are unsatisfactory and to require appropriate remedial measures.
- B. Man-Made Improvements: Protect, or remove and replace with the ENGINEER'S approval, all fences, walkways, mail boxes, pipe lines, drain culverts, power and telephone lines and cables, property pins and other improvements that may be encountered in the Work.
- C. Cultivated Growth: Do not disturb cultivated trees or shrubbery unless approved by the ENGINEER. Any such trees or shrubbery which must be removed shall be heeled in and replanted under the direction of an experienced nurseryman.
- D. Cutting of Trees: Do not cut trees for the performance of the work except as absolutely necessary. Protect trees that remain in the vicinity of the work from damage from equipment. Do not store spoil from excavation against the trunks. Remove excavated material stored over the root system of trees within 30 days to allow proper natural watering of the root system. Repair any damaged tree over 3-inches in diameter, not to be removed, under the direction of an experienced nurseryman. All trees and brush that require removal shall be promptly and completely removed from the work area and disposed of by the CONTRACTOR. No stumps, wood piles, or trash piles will be permitted on the work site.
- E. Disposal of Rubbish: Dispose of all materials cleared and grubbed during the construction of the Project in accordance with the applicable codes and rules of the appropriate county, state and federal regulatory agencies.

END OF SECTION

CITY UTILITIES COMMISSION

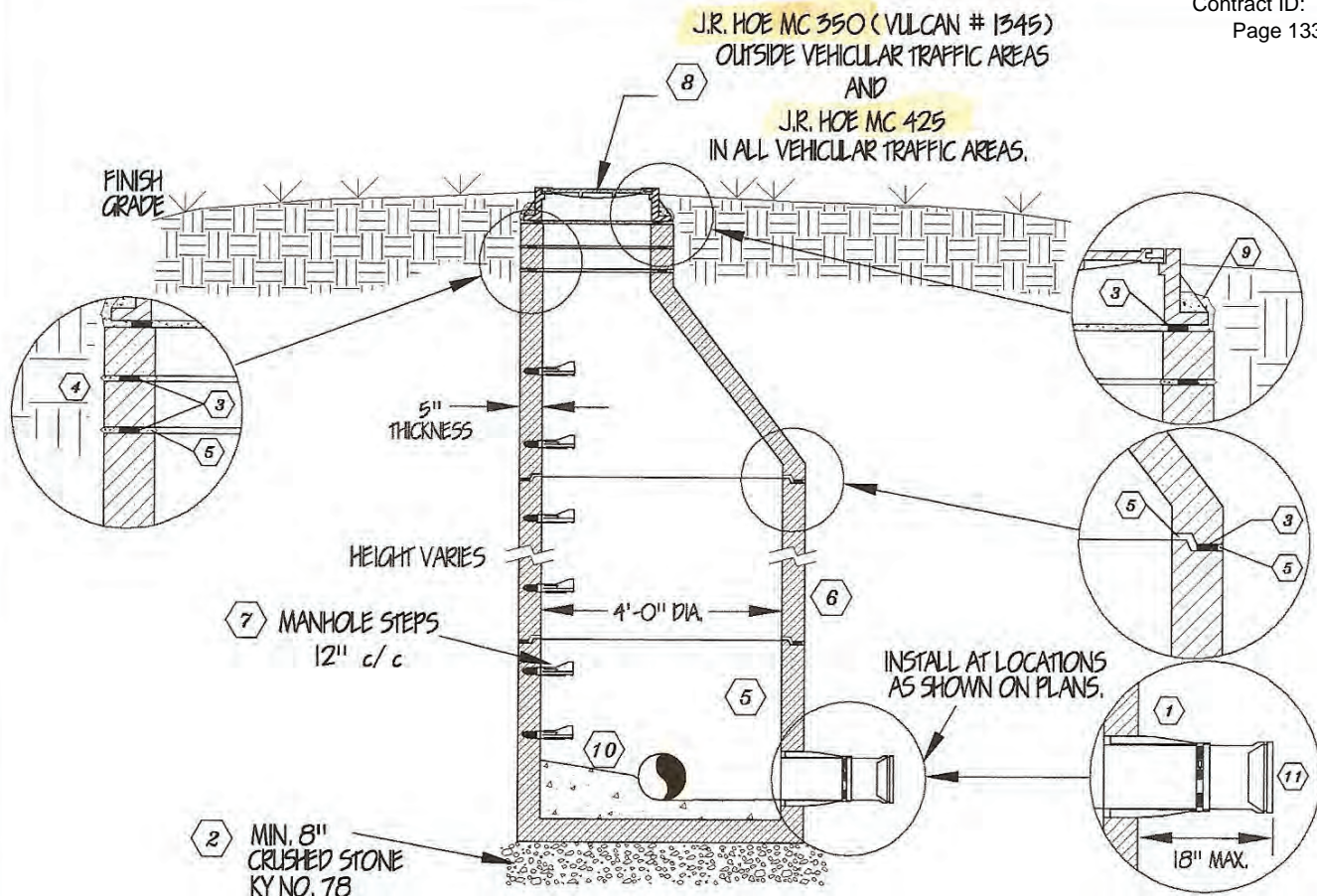

TYPICAL STANDARD PRE-CAST CONCRETE MANHOLE WITH STUB OUT DETAIL

NOTES:

- 1 WATERTIGHT NEOPRENE BOOTS SHALL BE "KOR-N-SEAL" AS MANUFACTURED BY NATIONAL POLLUTION CONTROL SYSTEMS INC. OR APPROVED EQUAL AT ALL INLET & OUTLET PIPES IN MANHOLE..
- 2 SET PRECAST MANHOLE ON KY NO. 78 CRUSHED STONE. MINIMUM OF 8 INCHES.
- 3 PLACE CONSEAL SEALANT OR "O" RINGS BETWEEN ALL JOINTS.
- 4 PLACE 2", 4" OR 6" CONCRETE MANHOLE GRADE RINGS AS REQUIRED (MAX 12").
- 5 GROUT JOINTS ON INTERIOR AND EXTERIOR OF MANHOLE BARREL SECTION.
- 6 COAT EXTERIOR WALLS OF MANHOLE INCLUDING FIELD GROUTED JOINTS WITH A BITUMINOUS FOUNDATION COATING AND ALLOW TO DRY 24 HRS. BEFORE BACKFILLING.
- 7 SEE CUC SEWER DETAIL - "TYPICAL PLASTIC MANHOLE STEP".
- 8 SEE CUC SEWER DETAIL - "TYPICAL MANHOLE FRAME & COVER".
- 9 SET FRAME IN MORTAR AND COAT WITH BITUMINOUS FOUNDATION COATING AND ALLOW TO DRY 24 HRS. BEFORE BACKFILLING.
- 10 FIELD GROUT WATER TABLE AND FLOW LINES TO INLET AND OUTLET OF ALL PIPES.
- 11 BELL & PLUG BY SAME MANUFACTURER.



CITY UTILITIES COMMISSION
901 SOUTH MAIN STREET
CORBIN, KY. 40701

TYPICAL STANDARD PRE-CAST CONCRETE MANHOLE WITH STUB OUT DETAIL SEWER DETAIL NO. 3

SCALE:	NONE
FILE NAME:	SE DETAIL 3
DATE:	10-86
DATE REVISED:	5-97
DRAWN BY:	J.W.N.
APPROVED BY:	G.P.R.
SHEET NO.:	1 OF 1

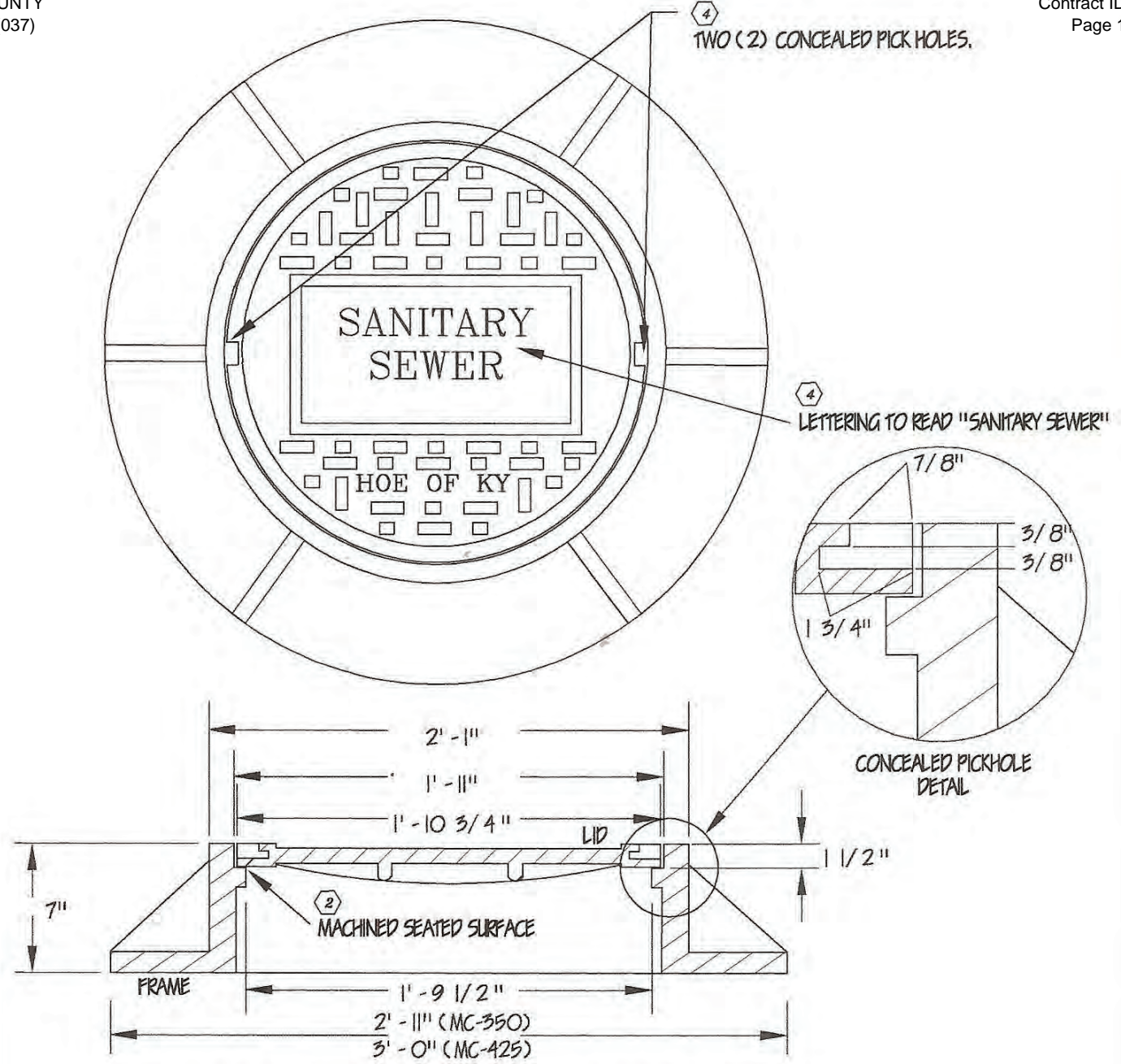

TYPICAL MANHOLE FRAME & COVER DETAIL

NOTES:

- 1 AND INSIDE OUTSIDE ROADWAY, A J.R. HOE MC-350(VULCAN #1345) OR J.R. HOE MC-425 FRAME AND COVER SHALL BE USED.
- 2 ~~INSIDE ROADWAY, OR WHERE EXPOSED TO VEHICULAR TRAFFIC, A J.R. HOE MC-425 FRAME AND COVER SHALL BE USED.~~
- 3 THE MANHOLE SEAT SHALL HAVE A MACHINED SURFACE.
- 4 THE MANHOLE LID SHALL HAVE TWO(2) CONCEALED PICKHOLES EACH AND READ "SANITARY SEWER".



CITY UTILITIES COMMISSION
901 SOUTH MAIN STREET
CORBIN, KY. 40701

TYPICAL MANHOLE FRAME
& COVER DETAIL

SEWER DETAIL NO. 27

SCALE:	NONE
FILE NAME:	SE DETAIL 27
DATE:	10-86
DATE REVISED:	5-97
DRAWN BY:	J.W.N.
APPROVED BY:	G.P.R.
SHEET NO.:	1 OF 1

CITY UTILITIES COMMISSION

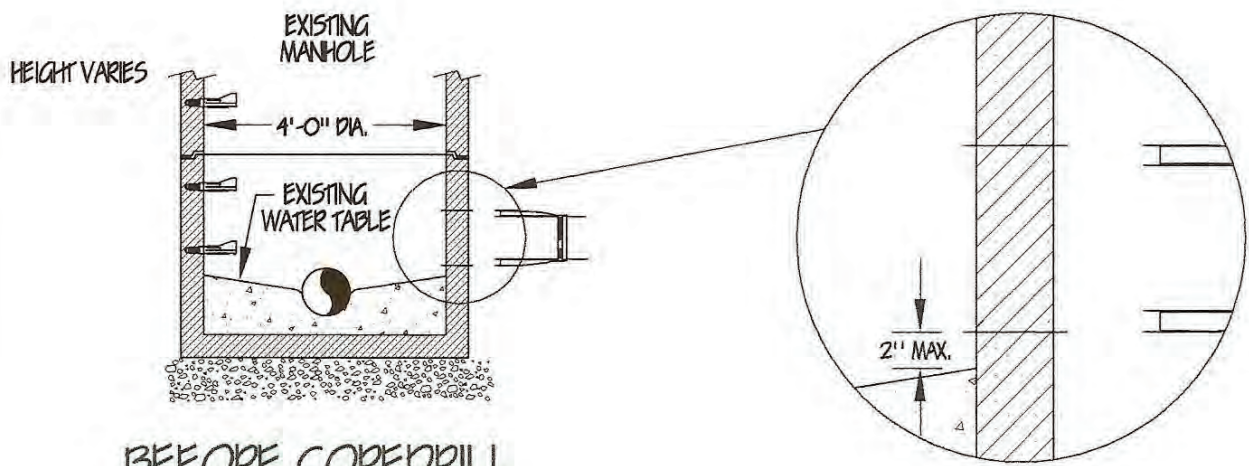

BEFORE COREDRILL

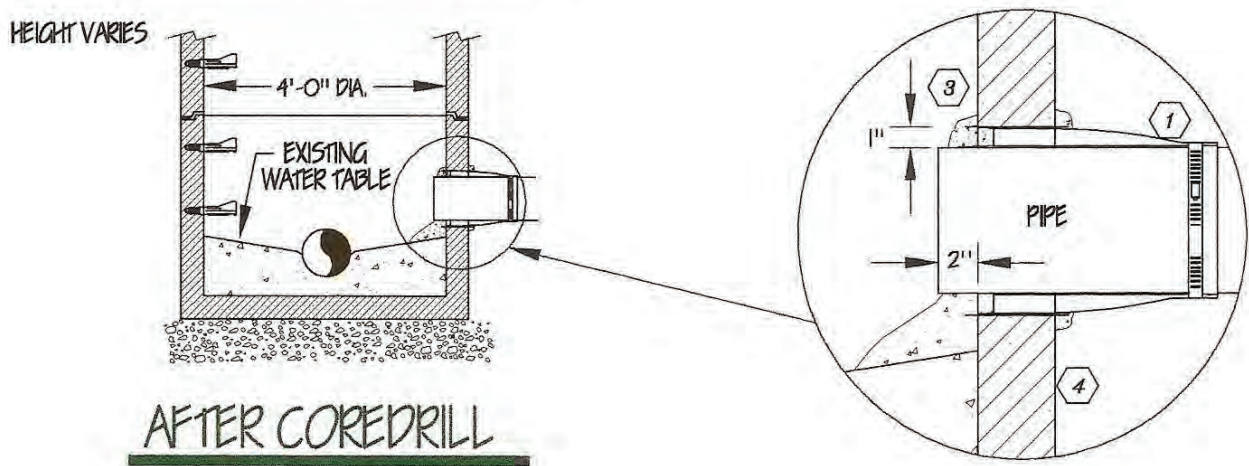

AFTER COREDRILL

NOTES:

- 1 WATERTIGHT NEOPRENE BOOTS SHALL BE "KOR-N-SEAL" AS MANUFACTURED BY NATIONAL POLLUTION CONTROL SYSTEMS INC. OR APPROVED EQUAL.
- 2 COREDRILL HOLE THROUGH MANHOLE WALL TO EXACT DIAMETER RECOMMENDED BY THE MANUFACTURER OF THE NEOPRENE BOOT; NAMELY, NATIONAL POLLUTION CONTROL SYSTEMS INC. AND JACK BOOT INTO PLACE.
- 3 GROUT COREHOLE AND PIPE INSIDE AND OUTSIDE OF MANHOLE.
- 4 COAT DISTURBED AREAS ON EXTERIOR WALLS OF MANHOLE WITH A BITUMINOUS FOUNDATION COATING AND ALLOW TO DRY 24 HRS. BEFORE BACKFILLING.



CITY UTILITIES COMMISSION
901 SOUTH MAIN STREET
CORBIN, KY. 40701

TYPICAL PIPE INSTALLATION
INTO
EXISTING MANHOLE DETAIL
SEWER DETAIL NO. 30

SCALE:	NONE
FILE NAME:	SE DETAIL 30
DATE:	10-86
DATE REVISED:	5-97
DRAWN BY:	J.W.N.
APPROVED BY:	G.P.R.
SHEET NO.:	1 OF 1

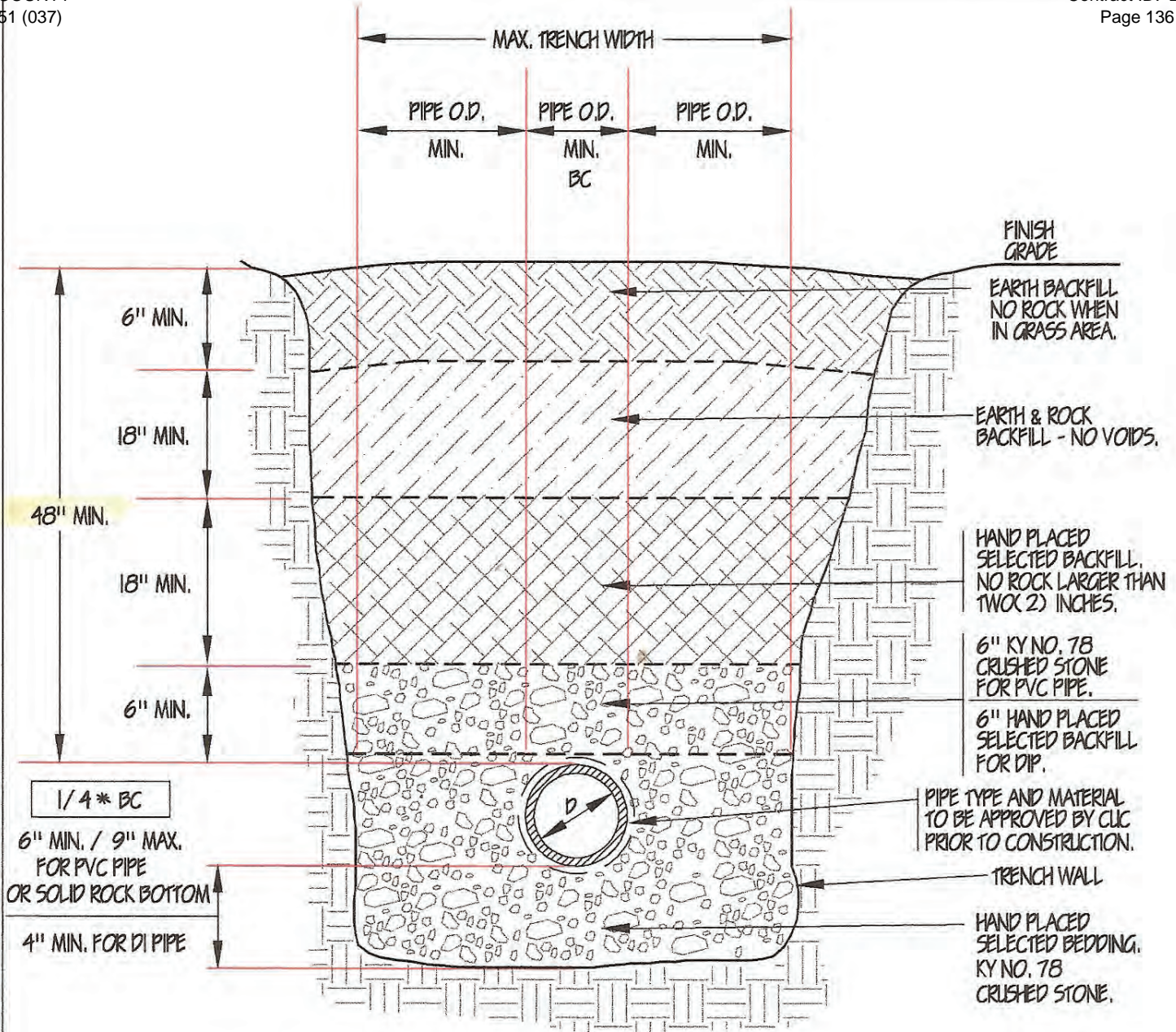

TYPICAL PVC / DI GRAVITY SEWER PIPE BEDDING AND BACKFILL FOR SEWERLINE INSTALLATION ON STABLE SOIL OR SOLID ROCK DETAIL

NOTES:

- 1 IN THE CASE OF OPEN-CUT CROSSING OF CITY, COUNTY, OR STATE ROADS, THE ENTIRE TRENCH SHALL BE BACKFILLED WITH KY NO. 78 CRUSHED STONE.
- 2 IF TRENCH BOTTOM IS SOLID ROCK, 6" MIN. OF HAND PLACED SELECTED PIPE BEDDING SHALL BE INSTALLED.



CITY UTILITIES COMMISSION
901 SOUTH MAIN STREET
CORBIN, KY. 40701

TYPICAL PVC / DI GRAVITY
SEWERLINE BEDDING AND BACKFILL
FOR SEWERLINE INSTALLATION ON
STABLE SOIL OR SOLID ROCK DETAIL

SEWER DETAIL NO. 33

SCALE:	NONE
FILE NAME:	SE DETAIL 33
DATE:	10-86
DATE REVISED:	5-97
DRAWN BY:	J.W.N.
APPROVED BY:	G.P.R.
SHEET NO.:	1 OF 1

CITY UTILITIES COMMISSION

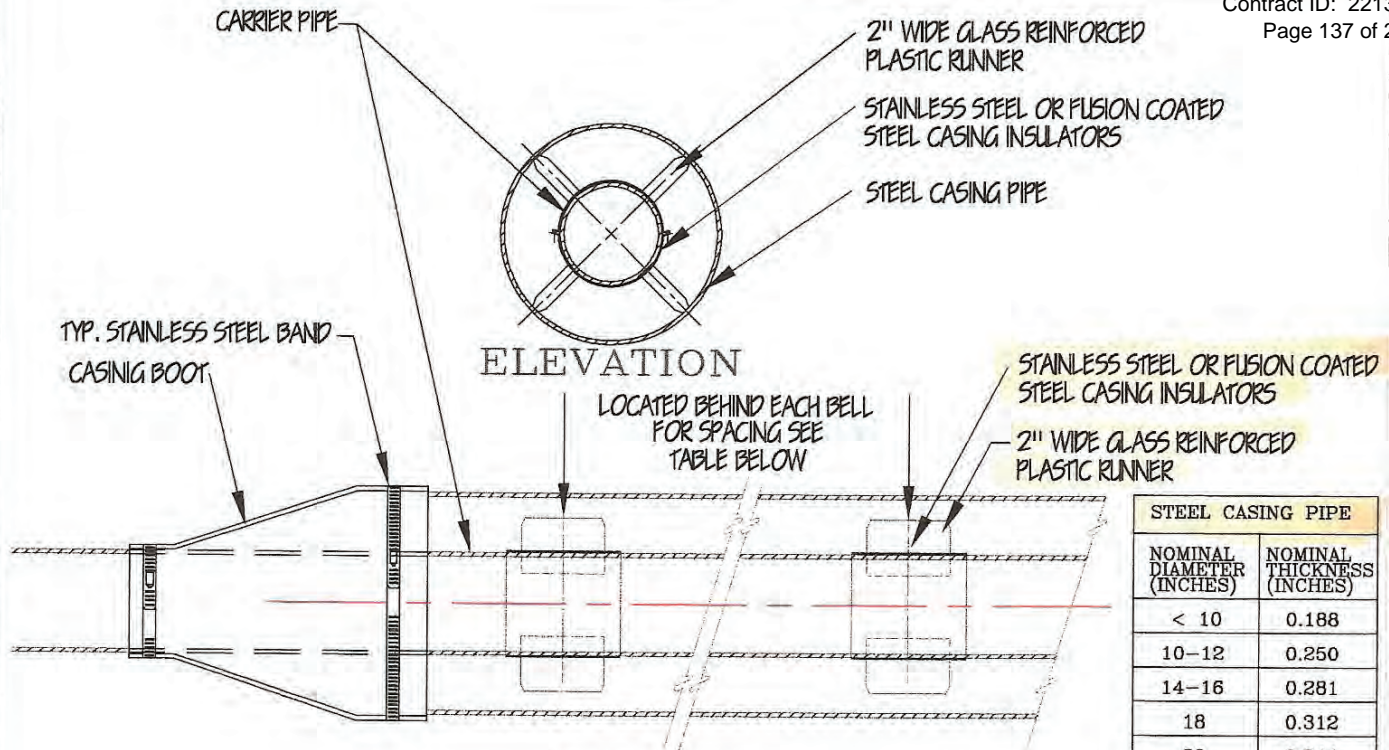

STEEL CASING PIPE	
NOMINAL DIAMETER (INCHES)	NOMINAL THICKNESS (INCHES)
< 10	0.188
10-12	0.250
14-16	0.281
18	0.312
20	0.344
22	0.375
24	0.438
26	0.438
28-32	0.500
34-42	0.562

PLAN
**TYPICAL PVC / DI SEWERLINE PIPE
IN COVER PIPE INSTALLATION DETAIL**

NOTES:

1 PIPELINE SPACERS

PIPES INSTALLED INSIDE COVER PIPES SHALL BE CENTERED THROUGHOUT THE LENGTH OF COVER PIPE. CENTERING SHALL BE ACCOMPLISHED BY THE INSTALLATION OF POLYETHYLENE PIPELINE SPACERS ATTACHED TO THE PIPE IN SUCH MANNER AS TO PREVENT THE DISLODMENT OF THE SPACERS AS THE CARRIER PIPE IS PULLED OR PUSHED THROUGH THE COVER PIPE. SPACERS SHALL BE OF SUCH DIMENSIONS TO PROVIDE (1) FULL SUPPORTIVE LOAD CAPACITY OF THE PIPE AND CONTENTS; (2) OF SUCH THICKNESS TO ALLOW INSTALLATION AND/OR REMOVAL OF THE PIPE; AND (3) TO ALLOW NO GREATER THAN 1/2 INCH MOVEMENT OF THE CARRIER PIPE WITHIN THE COVER PIPE AFTER CARRIER PIPE IS INSTALLED. SPACERS SHALL BE MANUFACTURED BY PSI, INC. HOUSTON, TEXAS.

SPACERS SHALL BE LOCATED IMMEDIATELY BEHIND EACH BELL AND AT A MAXIMUM SPACING DISTANCE AS FOLLOWS:

PIPELINE DIAMETER (IN.)	MODEL NUMBER	MAXIMUM SPACING (FT.)
4" - 8"	C8G-2	7'
10" - 24"	C12G-2	10'

2 END SEALS

UPON COMPLETION OF INSTALLATION OF THE CARRIER PIPE, THE ANNULAR SPACE AT THE ENDS OF THE COVER PIPE SHALL BE SEALED TO PREVENT THE ENTRANCE OF GROUNDWATER, SILT, ETC., INTO THE COVER PIPE. THE SEAL SHALL BE A MANUFACTURED PRODUCT SPECIALLY MADE FOR THIS PURPOSE. THE SEAL SHALL BE THE BEST SEAL TYPE CONSTRUCTED OF SYNTHETIC RUBBER WITH STAINLESS STEEL BANDING STRAPS. SEALS MAY BE OF THE "PULL-ON" MODEL "C" TYPE AS MANUFACTURED BY PSI, INC., HOUSTON TEXAS.

3 STEEL COVER PIPE

THE INSIDE DIAMETER OF STEEL COVER PIPE SHALL BE AT LEAST 2 INCHES GREATER THAN THE LARGEST OUTSIDE DIAMETER OF THE CARRIER PIPE, JOINTS OR COUPLINGS, EXCEPT FOR CARRIER PIPE 6 INCHES OR GREATER IN DIAMETER UNDER RAILROADS, THE DIFFERENCE SHALL BE 4 INCHES INSTEAD OF 2 INCHES.



CITY UTILITIES COMMISSION
901 SOUTH MAIN STREET
CORBIN, KY. 40701

**TYPICAL PVC / DI SEWERLINE PIPE
IN COVER PIPE WITH
END SEALS INSTALLATION DETAIL**

SEWER DETAIL NO. 48

SCALE:	NONE
FILE NAME:	SE DETAIL 48
DATE:	10-86
DATE REVISED:	5-97
DRAWN BY:	J.W.N.
APPROVED BY:	G.P.R.
SHEET NO.:	1 OF 1

CITY UTILITIES COMMISSION

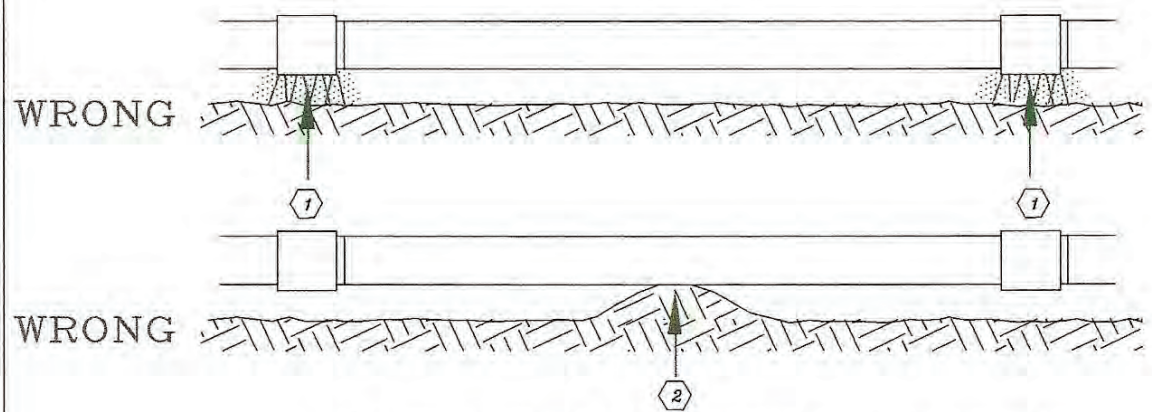
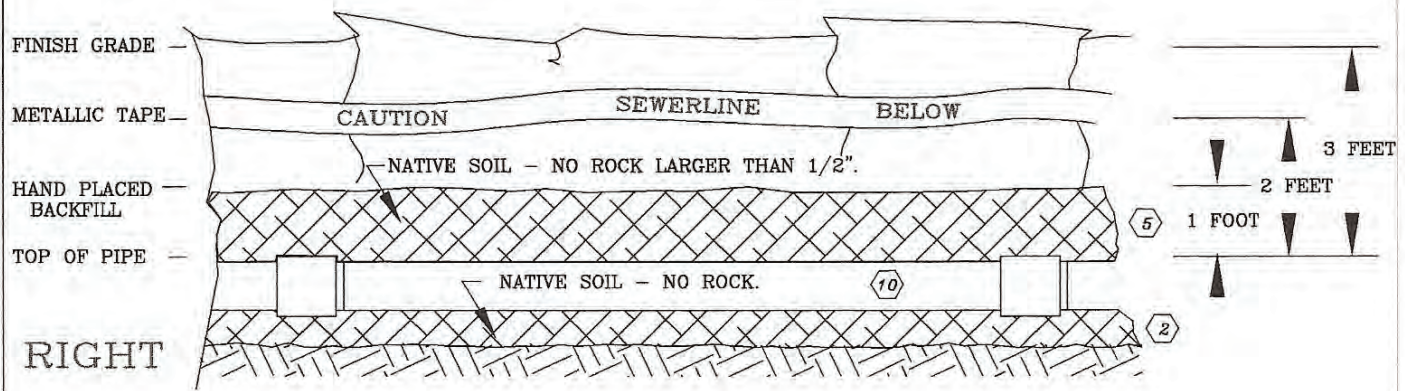

TYPICAL PVC SEWER FORCE MAIN WITH METALLIC TAPE INSTALLATION DETAIL

NOTES:

- 1 NEVER ALLOW BELLS TO REST ON, OR SETTLE DOWN TO ORIGINAL TRENCH BOTTOM.
- 2 MAKE CERTAIN THAT PIPE IS GIVEN AN EVEN BEARING FOR ITS ENTIRE LENGTH ON LOOSE NATIVE SOIL.
- 3 CARRY EXCAVATION 6-INCHES BELOW REQUIRED ELEVATION IN STABLE SOIL AREAS CONTAINING NO ROCKS. REPLACE WITH LOOSE NATIVE SOIL CONTAINING NO ROCK. WHEN ROCK IS ENCOUNTERED, CARRY EXCAVATION 6-INCHES BELOW REQUIRED ELEVATION AND REPLACE WITH LOOSE NATIVE SOIL CONTAINING NO ROCKS, AS REQUIRED BY THE OWNER/ENGINEER AT NO EXTRA COST TO THE OWNER.
- 4 PIPE SHALL BE HOMED USING A BAR AND BLOCK. NEVER HOME PIPE WITH A BACKHOE BUCKET.
- 5 BACKFILL SHALL BE HAND PLACED WITH SUITABLE MATERIAL TO 12-INCHES ABOVE THE TOP OF THE PIPE. ALL ROCK 1/2 INCH OR GREATER IN DIAMETER SHALL BE REMOVED FROM THE FIRST 12-INCHES.
- 6 PVC SEWER FORCE MAIN SHALL BE BACKFILLED 2-FT. PRIOR TO INSTALLING DETECTABLE TAPE DIRECTLY OVER PIPE.
- 7 TAPE SHALL BE TIED DIRECTLY TO ALL AIR RELEASE VALVES WHEN APPLICABLE.
- 8 THE TAPE SHALL READ "CAUTION SEWERLINE BELOW".
- 9 THE MAX. VERTICAL/HORIZONTAL DEFLECTION SHALL NOT EXCEED ONE-HALF (1/2) MFG. RECCOMENDATION.
- 10 ALL PVC SEWER FORCE MAIN SHALL BE C-900, DR-18 CLASS 150 (MIN).



CITY UTILITIES COMMISSION
901 SOUTH MAIN STREET
CORBIN, KY. 40701

PVC SEWER FORCE MAIN WITH METALLIC TAPE INSTALLATION DETAIL

SEWER DETAIL NO. 63

SCALE:	NONE
FILE NAME:	SE DETAIL 63
DATE:	10-86
DATE REVISED:	5-97
DRAWN BY:	JWN.
APPROVED BY:	GPR.
SHEET NO.:	1 OF 1

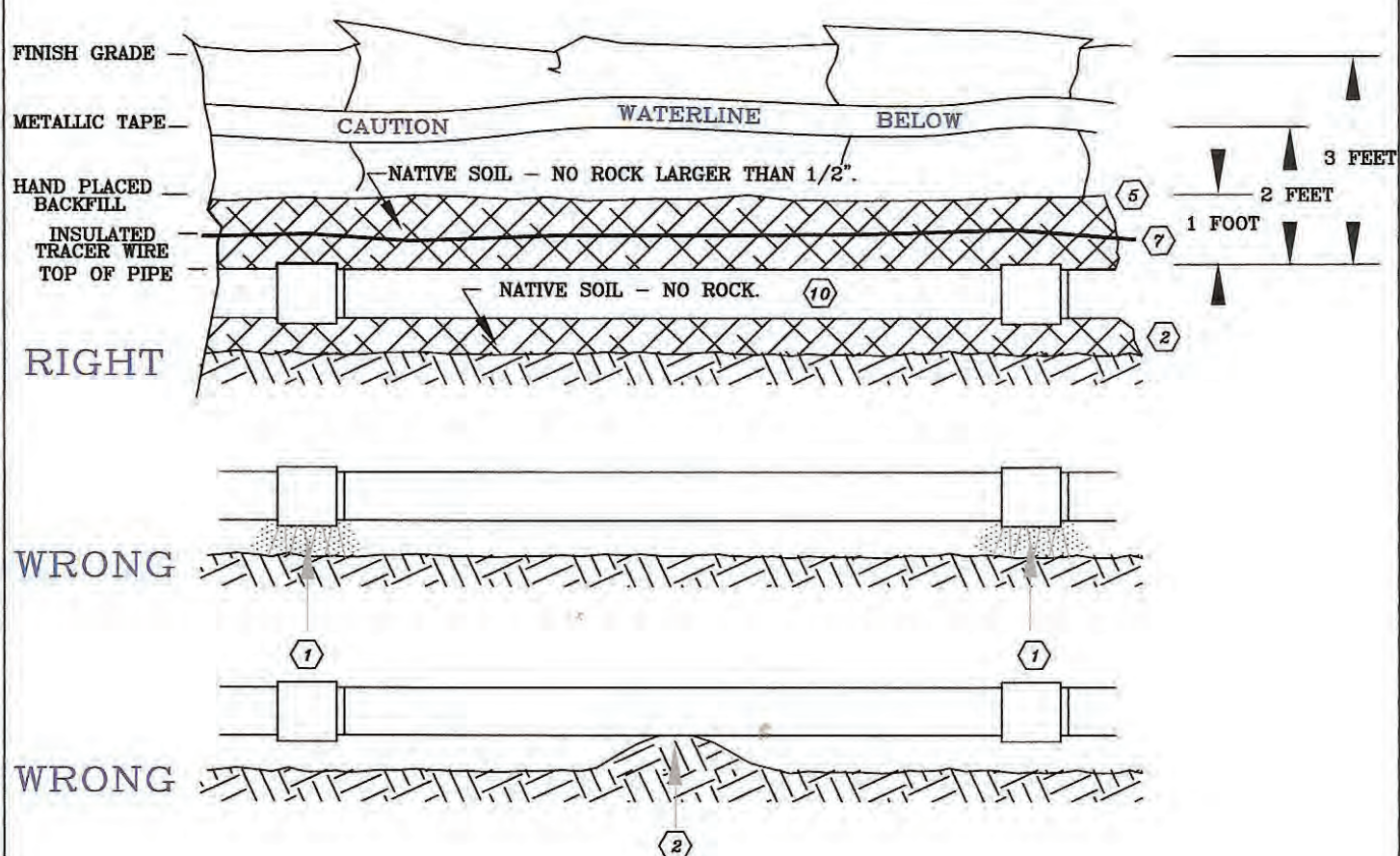

TYPICAL PVC WATERLINE WITH METALLIC TRACER WIRE INSTALLATION

NOTES:

- 1 NEVER ALLOW BELLS TO REST ON, OR SETTLE DOWN TO ORIGINAL TRENCH BOTTOM.
- 2 MAKE CERTAIN THAT PIPE IS GIVEN AN EVEN BEARING FOR ITS ENTIRE LENGTH ON LOOSE NATIVE SOIL.
- 3 CARRY EXCAVATION 6-INCHES BELOW REQUIRED ELEVATION IN STABLE SOIL AREAS CONTAINING NO ROCKS. REPLACE WITH LOOSE NATIVE SOIL CONTAINING NO ROCK. WHEN ROCK IS ENCOUNTERED, CARRY EXCAVATION 6-INCHES BELOW REQUIRED ELEVATION AND REPLACE WITH LOOSE NATIVE SOIL CONTAINING NO ROCKS, AS REQUIRED BY THE OWNER/ENGINEER AT NO EXTRA COST TO THE OWNER.
- 4 PIPE SHALL BE HOMED USING A BAR AND BLOCK. NEVER HOME PIPE WITH A BACKHOE BUCKET.
- 5 BACKFILL SHALL BE HAND PLACED WITH SUITABLE MATERIAL TO 12-INCHES ABOVE THE TOP OF THE PIPE. ALL ROCK 1/2 INCH OR GREATER IN DIAMETER SHALL BE REMOVED FROM THE FIRST 12-INCHES.
- 6 PVC WATERLINE SHALL BE BACKFILLED 2-FEET PRIOR TO INSTALLING DETECTABLE INSULATED WIRE DIRECTLY OVER PIPE.
- 7 TRACER WIRE SHALL BE TIED DIRECTLY TO ALL VALVES, HYDRANTS AND SERVICE LINES.
- 8 THE TAPE SHALL READ "CAUTION WATERLINE BELOW".
- 9 THE MAX. VERTICAL/HORIZONTAL DEFLECTION SHALL NOT EXCEED ONE-HALF (1/2) MFG. RECCOMENDATION.
- 10 ALL PVC WATERLINE SHALL BE C-900, DR-18 CLASS 150 (MIN).



CITY UTILITIES COMMISSION
1515 CUMBERLAND FALLS HWY.
CORBIN, KY. 40701

PVC WATERLINE WITH TRACER WIRE INSTALLATION

WATER DETAIL NO. 3

SCALE:	NONE
FILE NAME:	WA DETAIL 3
DATE:	10-86
DATE REVISED:	10-13
DRAWN BY:	J.W.N.
APPROVED BY:	R.W.H.
SHEET NO.:	1 OF 1

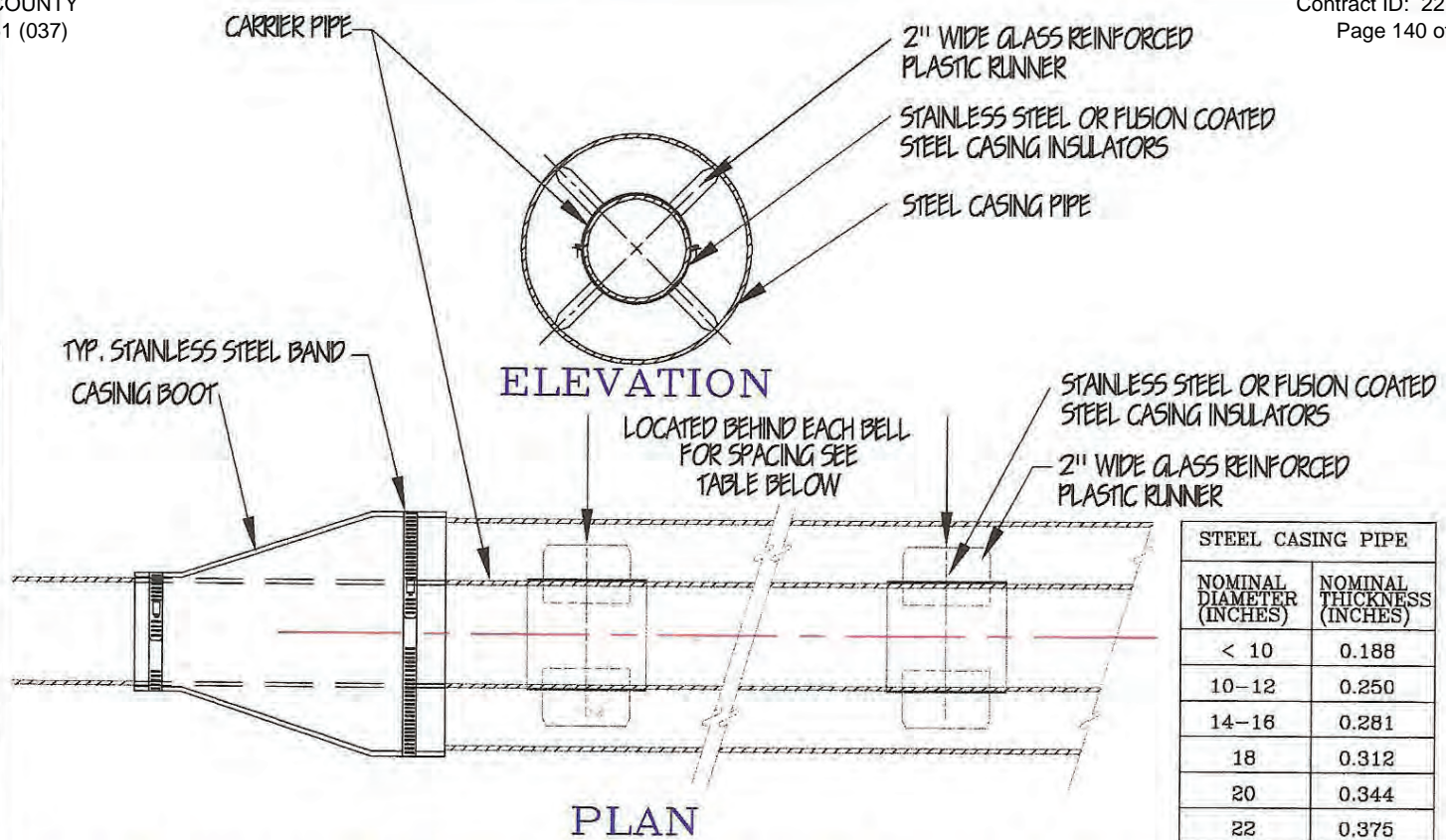

STEEL CASING PIPE	
NOMINAL DIAMETER (INCHES)	NOMINAL THICKNESS (INCHES)
< 10	0.188
10-12	0.250
14-16	0.281
18	0.312
20	0.344
22	0.375
24	0.438
26	0.438
28-32	0.500
34-42	0.562

TYPICAL WATERLINE PIPE IN COVER PIPE INSTALLATION

NOTES:

1 PIPELINE SPACERS

PIPES INSTALLED INSIDE COVER PIPES SHALL BE CENTERED THROUGHOUT THE LENGTH OF COVER PIPE. CENTERING SHALL BE ACCOMPLISHED BY THE INSTALLATION OF POLYETHYLENE PIPELINE SPACERS ATTACHED TO THE PIPE IN SUCH MANNER AS TO PREVENT THE DISLODGMET OF THE SPACERS AS THE CARRIER PIPE IS PULLED OR PUSHED THROUGH THE COVER PIPE. SPACERS SHALL BE OF SUCH DIMENSIONS TO PROVIDE (1) FULL SUPPORTIVE LOAD CAPACITY OF THE PIPE AND CONTENTS; (2) OF SUCH THICKNESS TO ALLOW INSTALLATION AND/OR REMOVAL OF THE PIPE; AND (3) TO ALLOW NO GREATER THAN 1/2 INCH MOVEMENT OF THE CARRIER PIPE WITHIN THE COVER PIPE AFTER CARRIER PIPE IS INSTALLED. SPACERS SHALL BE MANUFACTURED BY PSI, INC. HOUSTON, TEXAS.

SPACERS SHALL BE LOCATED IMMEDIATELY BEHIND EACH BELL AND AT A MAXIMUM SPACING DISTANCE AS FOLLOWS:

PIPELINE DIAMETER (IN.)	MODEL NUMBER	MAXIMUM SPACING (FT.)
4" - 8"	C8G-2	7'
10" - 24"	C12G-2	10'

2 END SEALS

UPON COMPLETION OF INSTALLATION OF THE CARRIER PIPE, THE ANNULAR SPACE AT THE ENDS OF THE COVER PIPE SHALL BE SEALED TO PREVENT THE ENTRANCE OF GROUNDWATER, SILT, ETC., INTO THE COVER PIPE. THE SEAL SHALL BE A MANUFACTURED PRODUCT SPECIALLY MADE FOR THIS PURPOSE. THE SEAL SHALL BE THE BEST SEAL TYPE CONSTRUCTED OF SYNTHETIC RUBBER WITH STAINLESS STEEL BANDING STRAPS. SEALS MAY BE OF THE "PULL-ON" MODEL "C" TYPE AS MANUFACTURED BY PSI, INC., HOUSTON TEXAS.

3 STEEL COVER PIPE

THE INSIDE DIAMETER OF STEEL COVER PIPE SHALL BE AT LEAST 2 INCHES GREATER THAN THE LARGEST OUTSIDE DIAMETER OF THE CARRIER PIPE, JOINTS OR COUPLINGS, EXCEPT FOR CARRIER PIPE 6 INCHES OR GREATER IN DIAMETER UNDER RAILROADS, THE DIFFERENCE SHALL BE 4 INCHES INSTEAD OF 2 INCHES.



CITY UTILITIES COMMISSION
901 SOUTH MAIN STREET
CORBIN, KY. 40701

TYPICAL WATERLINE PIPE IN COVER PIPE WITH END SEALS INSTALLATION

WATER DETAIL NO. 24

SCALE:	NONE
FILE NAME:	WA DETAIL 24
DATE:	10-86
DATE REVISED:	5-97
DRAWN BY:	J.W.N.
APPROVED BY:	G.P.R.
SHEET NO.:	1 OF 1

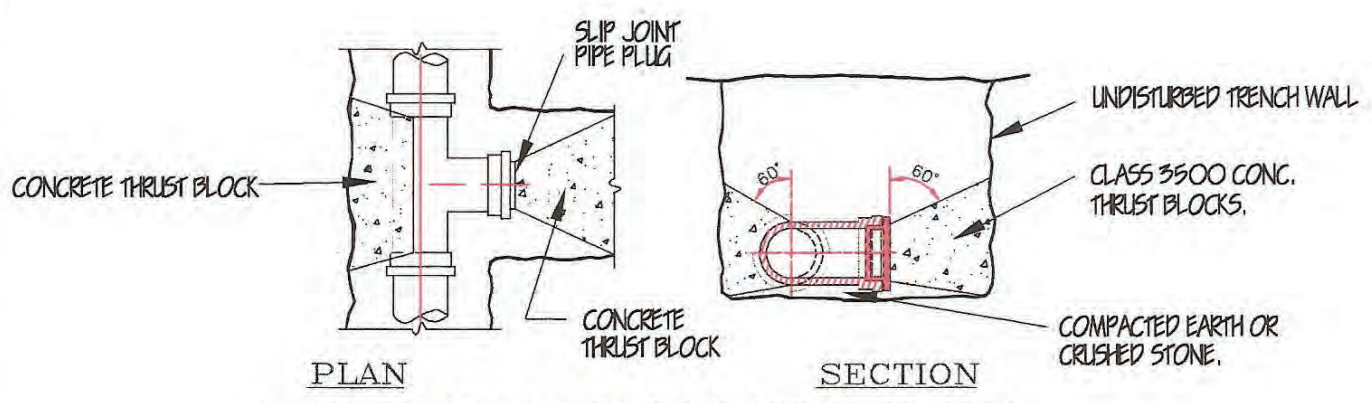

CONCRETE BACKING AT TEES & PLUGS

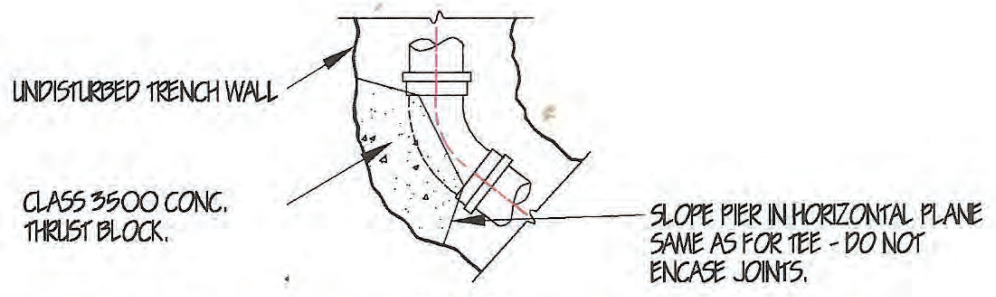

CONCRETE BACKING AT HORIZONTAL BENDS

NOTES:

- 1 SEE TABLE A & B ATTACHED FOR MINIMUM BEARING AREAS FOR BLOCKING.
- 2 IF A MECHANICAL JOINT PLUG IS USED ON THE "TEE" BRANCH, NO BLOCKING WILL BE REQUIRED AT THE PLUG. THE BACK SIDE OF TEE SHALL BE BLOCKED IN ALL CASES.



CITY UTILITIES COMMISSION
901 SOUTH MAIN STREET
CORBIN, KY. 40701

TYPICAL WATERLINE BACKING
WATER DETAIL NO. 27

SCALE:	NONE
FILE NAME:	WA DETAIL 27
DATE:	10-86
DATE REVISED:	6-97
DRAWN BY:	J.W.N.
APPROVED BY:	G.P.R.
SHEET NO.:	1 OF 2

⬡ NOTES: (CONTINUED)

③ BLOCKING OF PIPE AT BENDS AND ENDS.

HORIZONTAL BENDS

CONCRETE BACKING AND/OR BLOCKING REQUIRED AT BENDS IN THE HORIZONTAL PLANE SHALL BE ACCOMPLISHED PER CUC DETAIL. THE SQUARE FOOTAGE OF BLOCKING AREA SHALL BE OBTAINED FROM TABLES "A" AND "B" THROUGH THE FOLLOWING PROCEDURE:

- STEP NO. 1 - FROM TABLE "A" SELECT TYPE SOIL AND BEARING AREA FACTOR FOR PARTICULAR FITTING TO BE BLOCKED.
- STEP NO. 2 - FROM TABLE "B" SELECT MULTIPLIER TO BE USED FOR THE SIZE PIPE BEING BLOCKED AND ITS TEST PRESSURE.
- STEP NO. 3 - CALCULATE ACTUAL BEARING AREA REQUIRED BY MULTIPLYING BEARING AREA FACTOR FROM TABLE "A" BY MULTIPLIER FROM TABLE "B" (e.g. - 16 INCH TEE WITH 250 PSI TEST PRESSURE IN SANDY CLAY - 9.42 X 1.78 = 16.7 S.F. OF BEARING AREA REQUIRED). BEARING AREA SHALL IN NO CASE BE LESS THAN THE MINIMUM SHOWN IN TABLE "B".

TABLE "A"						
BEARING AREA FACTOR FOR DEGREE OF BEND (SQUARE FEET)						
TYPE SOIL	SOIL BEARING PRESSURE	90°	PLUG/TEE	45°	22 1/2°	11 1/4°
SANDY SOIL	3,000 <i>psf</i>	13.33	9.42	7.21	3.68	1.85
HARD CLAY	6,000	6.66	4.71	3.61	1.84	0.92
SHALE	12,000	3.33	2.36	1.80	0.92	0.46
SOLID ROCK	16,000	2.50	1.77	1.35	0.69	0.35

TABLE "B"								
MULTIPLIER FOR PIPE TEST PRESSURE (TP)								
PIPE DIA. (IN.)	MIN BEARING AREA (S.F.)	350 PSI	300 PSI	250 PSI	200 PSI	150 PSI	100 PSI	50 PSI
6	1.0	0.35	0.30	0.25	0.20	0.15	0.10	0.05
8	1.0	0.62	0.53	0.44	0.36	0.27	0.18	0.09
10	1.0	0.97	0.83	0.69	0.56	0.42	0.28	0.14
12	1.3	1.40	1.20	1.00	0.80	0.60	0.40	0.20
16	1.8	2.49	2.13	1.78	1.42	1.07	0.71	0.36
24	3.6	5.60	4.80	4.00	3.20	2.40	1.60	0.80

HORIZONTAL BENDS

- A. THE USE OF VERTICAL BENDS IN LIEU OF EXTRA DEPTH TRENCHING SHALL BE SUBJECT TO PERMISSION BY THE CUC.
- B. WHERE VERTICAL BENDS ARE APPROVED FOR USE BY THE CUC, THE CONTRACTOR SHALL SUBMIT THE BLOCKING DESIGN, INCLUDING CALCULATIONS, TO THE CUC FOR APPROVAL.



CITY UTILITIES COMMISSION
901 SOUTH MAIN STREET
CORBIN, KY. 40701

TYPICAL WATERLINE BACKING

WATER DETAIL NO. 27

SCALE:	NONE
FILE NAME:	WA DETAIL 27
DATE:	10-86
DATE REVISED:	6-97
DRAWN BY:	J.W.N.
APPROVED BY:	G.P.R.
SHEET NO.:	2 of 2

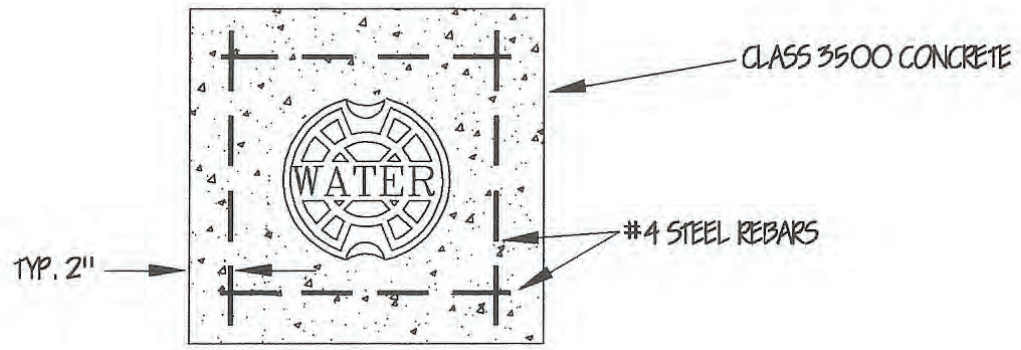

TOP VIEW

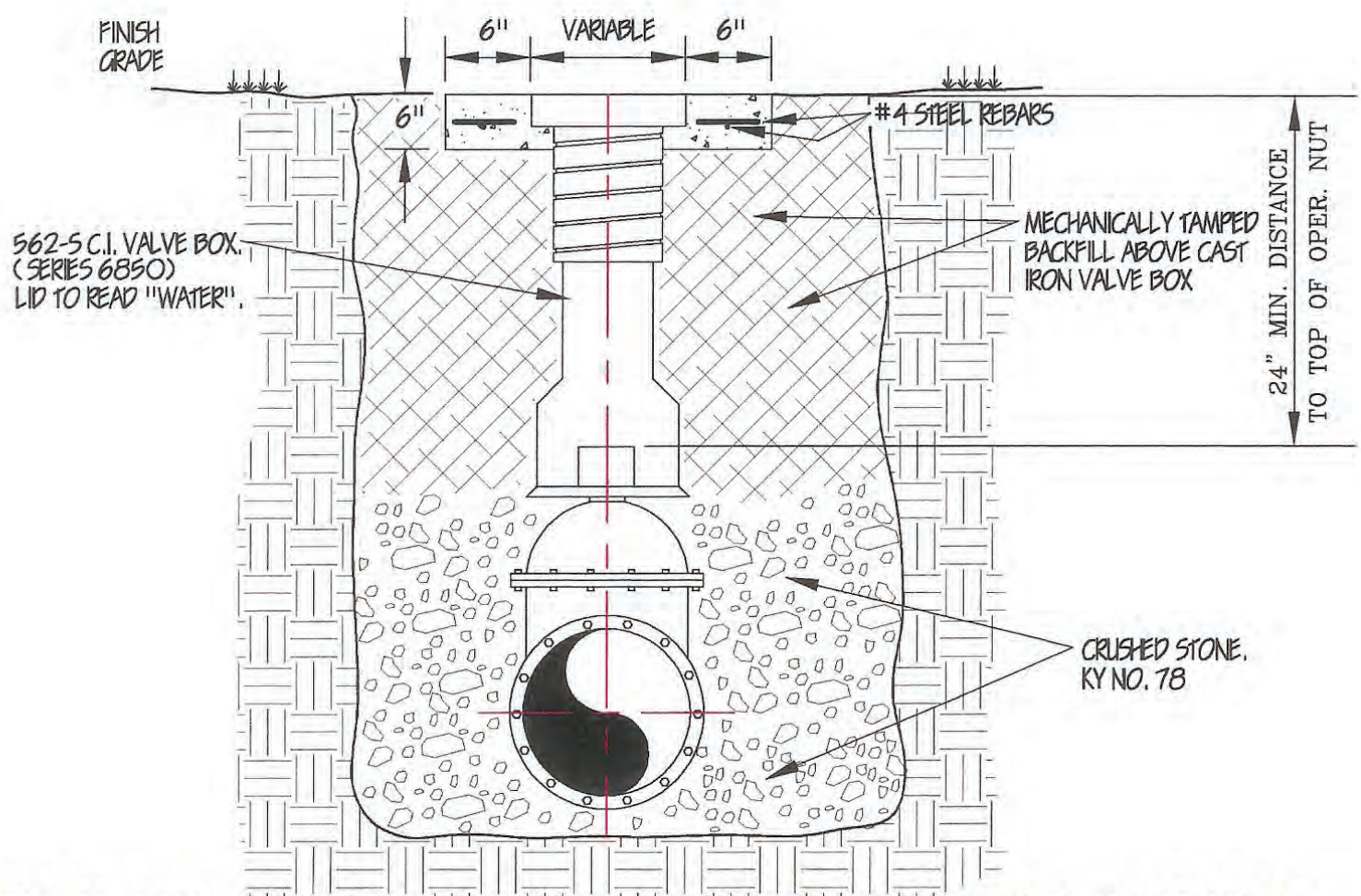

TYPICAL VALVE & VALVE BOX INSTALLATION (OUTSIDE ROADWAY)



CITY UTILITIES COMMISSION
901 SOUTH MAIN STREET
CORBIN, KY. 40701

TYPICAL VALVE & VALVE BOX
INSTALLATION (OUTSIDE ROADWAY)

WATER DETAIL NO. 33

SCALE:	NONE
FILE NAME:	WA DETAIL 33
DATE:	10-86
DATE REVISED:	5-97
DRAWN BY:	J.W.N.
APPROVED BY:	G.P.R.
SHEET NO.:	1 OF 1

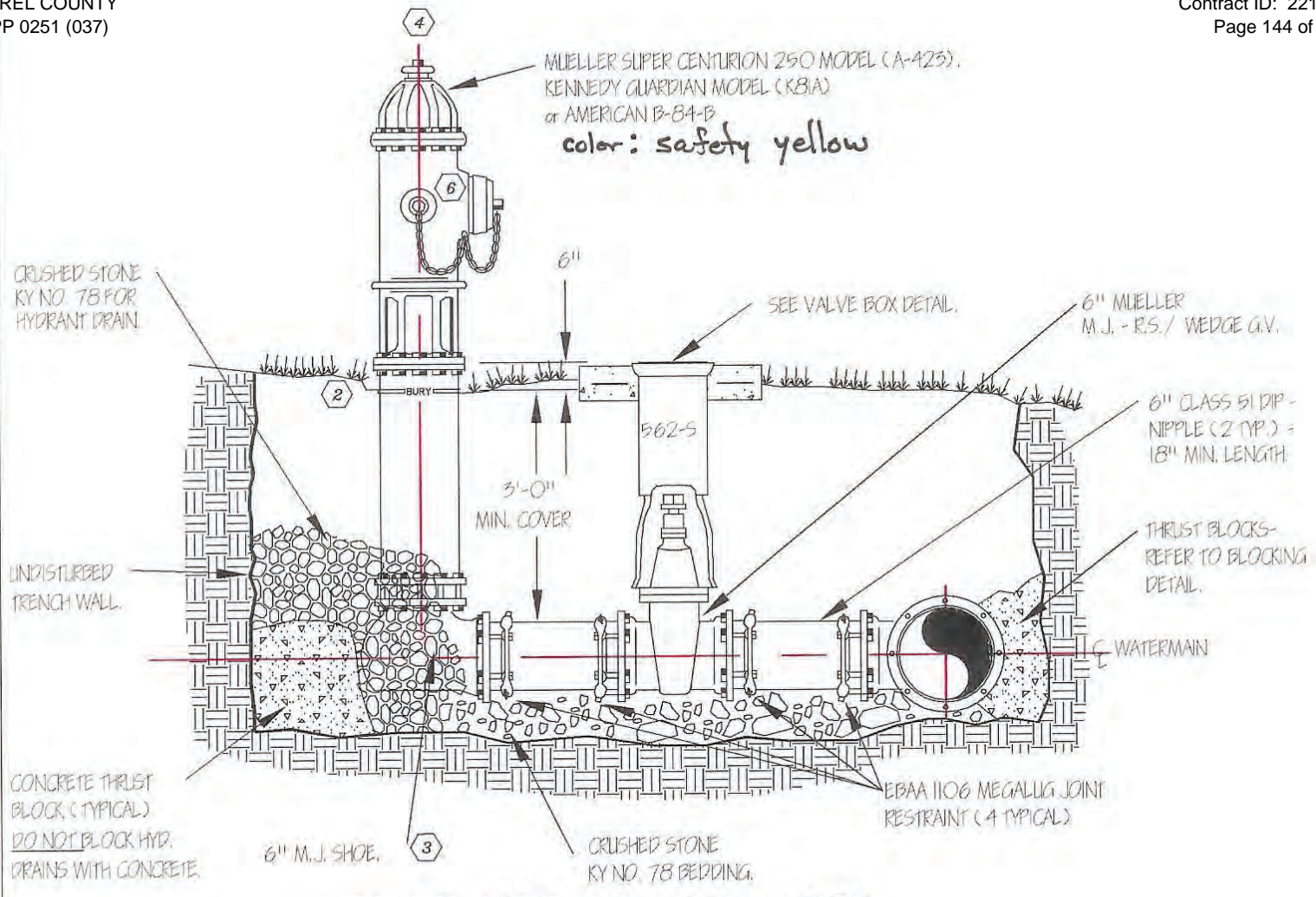

TYPICAL HYDRANT INSTALLATION

NOTES:

HYDRANTS SHALL HAVE THE FOLLOWING:

- 1 5 1/4" VALVE OPENING.
- 2 MINIMUM DEPTH OF BURY TO BE 3.5 FEET.
- 3 6" M.J. SHOE.
- 4 STANDARD 1 1/2" PENTAGON OPERATING NUT.
- 5 OPEN LEFT (COUNTER CLOCKWISE).
- 6 1-4 1/2" PUMPER NOZZLE & 2-2 1/2" HOSE NOZZLES WITH NATIONAL STANDARD THREADS.
- 7 COLOR - RED.
- 8 IF FACTORY MUTUAL APPROVAL IS REQUIRED, A MUELLER SUPER CENTURIAN 250, MODEL A-423 SHALL BE USED.



CITY UTILITIES COMMISSION
901 SOUTH MAIN STREET
CORBIN, KY. 40701

TYPICAL
HYDRANT INSTALLATION

WATER DETAIL NO. 36

SCALE:	NONE
FILE NAME:	WA DETAIL 36
DATE:	10-86
DATE REVISED:	6-03
DRAWN BY:	J.W.N.
APPROVED BY:	R.W.H.
SHEET NO.:	1 OF 1

Standard Sanitary Sewer Bid Item Descriptions

S BYPASS PUMPING This item shall include all labor, equipment, and materials needed to complete a bypass pumping and/or hauling operation for diversion of sewage during sanitary sewer construction. Examples of such operations when bypass pumping and/or hauling may be necessary is during force main tie-ins, manhole invert reconstruction, insertion of new manholes into existing mains, or other similar construction. There may be more than one bypass pumping/hauling operation on a project. This item shall be paid for each separate bypass pumping/hauling operation occurrence as called out on the plans or directed by the engineer and actually performed. There will be no separate bid items defined for length, duration, or volume of sewage pumped or hauled in each occurrence. If a bypass pumping/hauling operation is called out on the plans; but, conditions are such that the bypass pumping/hauling operation is not needed or utilized, no payment will be made under this item. The contractor shall draw his own conclusions as to what labor, equipment, and materials may be needed for each bypass pumping/hauling occurrence. The contractor should be prepared to handle the maximum volume of the sewer being bypassed, even during a storm event. This item shall not be paid separately, but shall be considered incidental, when bypass pumping and/or hauling is needed during cast-in-place-pipe (CIPP) and/or point repair operations. Please refer to the Utility Company's Specifications. If the Company does not have specifications, KYTC's Specifications shall be referenced. This item shall be paid EACH (EA).

S CIPP LATERAL SERVICE INVESTIGATION This item shall include all equipment, materials, labor and incidentals necessary to enter the sewer in compliance with all safety/confined space requirements and perform the identification, assessment and pre-measurement of all existing and abandoned laterals for the placement of Cured-In-Place-Pipe lining. This item shall be in payment for all lateral service investigation for all sewer segments to be lined as a part of this contract. This bid item shall include bypass pumping when required. Please refer to the Utility Company's Specifications. If the Company does not have specifications, KYTC's Specifications shall be referenced. Payment for this item shall be LUMP SUM (LS).

S CIPP LATERAL REINSTATEMENT This item is to pay for installing a Cured-In-Place-Pipe liner in service laterals and service/mainline connections to stabilize structural defects and construction inadequacies. This bid item shall include all labor, equipment, materials and incidentals necessary to perform the service lateral reinstatement in accordance with the plans and specifications. Work under this item shall include bypass pumping, sewer flow control, pre-installation cleaning, sealing connections to existing sewer main, pre- and post- construction CCTV inspection and final testing of the CIPP system. This item shall also include the "top hat" required by the specifications. All CIPP lateral reinstatements shall be paid under this item regardless of the size or length of reinstatement. No separate bid items of varying sizes or length of CIPP lateral reinstatement will be provided in the contract. Please refer to the Utility Company's Specifications. If the Company does not have specifications, KYTC's Specifications shall be referenced. Payment for this item shall be EACH (EA) for each CIPP lateral reinstatement complete and ready for use.

S CIPP LINER This bid Item is to pay for rehabilitation of existing sanitary sewers using the Cured-In-Place-Pipe method. This bid item description applies to all CIPP sizes included in the contract.

All CIPP Liner items of all varying sizes shall include all labor, materials, customer notification, testing, necessary permits, ingress and egress procedures, bypass pumping, pre-construction video, sediment and root removal, dewatering, traffic control, erosion and sediment control, excavation pits, removal and replacement of manhole frames and covers as necessary to facilitate the lining work, sealing at manholes and service connections, clearing and grubbing, pipeline cleaning, re-cleaning and video inspection as many times as necessary, debris collection and disposal, root removal, pre- and post-construction video inspection, all digital inspection footage, final report preparation and approval, the cost of potable water from the Owner, required compliance tests, site restoration, site cleanup, sealing of liner at manholes, acceptance testing and all other rehabilitation work and incidentals not included under other pay items necessary to complete the rehabilitation per the plans and specifications. There will be no separate payment for acceptance testing of the lined pipe; but shall be considered incidental to this item. Pay under this item shall be by each size bid in the contract. Pay measurement shall be from center of manhole to center of manhole. Please refer to the Utility Company's Specifications. If the Company does not have specifications, KYTC's Specifications shall be referenced. This item shall be paid LINEAR FEET (LF).

S CIPP PROTRUDING LATERAL REMOVAL This item includes all equipment, materials, labor and incidentals necessary to enter the sewer in compliance with all safety/confined space requirements, remove a sufficient amount of the protruding tap to insure a proper and safe Cured-In-Place-Pipe lining insertion and perform pre-installation CCTV. This bid item shall include bypass pumping when required. Please refer to the Utility Company's Specifications. If the Company does not have specifications, KYTC's Specifications shall be referenced. Payment for this item shall be EACH (EA) for each protruding lateral removed.

S CONCRETE PIPE ANCHOR This item shall be constructed on the sewer pipe at the locations shown on the plans in accordance with sanitary sewer specifications and standard drawings. Payment for concrete anchors will be made at the contract unit price each in place complete and ready for use. Each concrete anchor of sewer pipe or force main shall be paid under one bid item per contract regardless of the sizes of carrier pipe being anchored in the contract. No separate bid items will be established for size variations. Please refer to the Utility Company's Specifications. If the Company does not have specifications, KYTC's Specifications shall be referenced. This item shall be paid EACH (EA) when complete.

S DIRECTIONAL BORE Payment under this item is made whenever the plans or specifications specifically show directional boring is to be utilized in order to minimize the impact of open cut for the installation of force main or gravity sewer under streets, creeks, and etc. Payment under this item shall include the specified bore pipe, labor, and equipment. No separate payment shall be made for bore pipe installed in the bore whether used as a carrier pipe or an encasement of a separate carrier pipe. This item shall also include pipe anchors at each end of the bore when specified to prevent the creep or contraction of the bore pipe. Carrier pipe installed within a bore pipe shall be paid separately under pipe items. Payment under this item shall not be size specific and no separate bid items will be established for size variations. The bore pipe sizes to be included under this item shall be as shown on the plans and/or in the specifications. Any and all directional bores in each contract shall be paid under one directional bore bid item included in the contract regardless of size. Please refer to the Utility Company's Specifications. If the Company does not have specifications, KYTC's Specifications shall be referenced. This item shall be paid LINEAR FEET (LF).

S ENCASEMENT CONCRETE Includes all labor, equipment, excavation, concrete, reinforcing

steel, backfill, restoration, and etc., to construct the concrete encasement of the sewer or force main as shown on the plans, and in accordance with the specifications and standard drawings. Payment under this item shall be in addition to the carrier pipe as paid under separate bid items. Carrier pipe is not included in this bid item. Any and all concrete encasement shall be paid under one bid item included in the contract regardless of the size of the carrier pipe or the volume of concrete or steel reinforcement as specified in the plans and specifications. No separate bid items will be established for size variations. Measurement of pay quantity shall be from end of concrete to end of concrete. Please refer to the Utility Company's Specifications. If the Company does not have specifications, KYTC's Specifications shall be referenced. This item shall be paid LINEAR FEET (LF) when complete.

S ENCASEMENT STEEL BORED This item shall include the steel encasement pipe size as specified on the plans and in the specifications, casing spacers, end seals, labor, and equipment to bore and install the encasement in accordance with the plans and specifications, complete and ready for use. The size shall be the measured internal diameter of the encasement pipe. The sizes of encasement to be paid under the size ranges specified in the bid items shall be as follows:

- Range 1 = All encasement sizes greater than 2 inches to and including 6 inches
- Range 2 = All encasement sizes greater than 6 inches to and including 10 inches
- Range 3 = All encasement sizes greater than 10 inches to and including 14 inches
- Range 4 = All encasement sizes greater than 14 inches to and including 18 inches
- Range 5 = All encasement sizes greater than 18 inches to and including 24 inches
- Range 6 = All encasement sizes greater than 24 inches

(Encasement sizes of 2 inches internal diameter or less shall not be paid separately; but, shall be considered incidental to the carrier pipe.) Payment under this bid item shall not include the carrier pipe. Carrier pipe shall be paid under a separate bid item. Please refer to the Utility Company's Specifications. If the Company does not have specifications, KYTC's Specifications shall be referenced. This item shall be paid LINEAR FEET (LF).

S ENCASEMENT STEEL OPEN CUT This item shall include the steel encasement pipe size as specified on the plans and in the specifications, casing spacers, end seals, labor, and equipment to open cut install the encasement in accordance with the plans and specifications, complete and ready for use. The size shall be the measured internal diameter of the encasement pipe. The size encasement to be paid under the size ranges specified in the bid items shall be as follows:

- Range 1 = All encasement sizes greater than 2 inches to and including 6 inches
- Range 2 = All encasement sizes greater than 6 inches to and including 10 inches
- Range 3 = All encasement sizes greater than 10 inches to and including 14 inches
- Range 4 = All encasement sizes greater than 14 inches to and including 18 inches
- Range 5 = All encasement sizes greater than 18 inches to and including 24 inches
- Range 6 = All encasement sizes greater than 24 inches

(Encasement sizes of 2 inches internal diameter or less shall not be paid separately; but, shall be considered incidental to the carrier pipe.) Payment under this bid item shall not include the carrier pipe. Carrier pipe shall be paid under a separate bid item. Please refer to the Utility Company's Specifications. If the Company does not have specifications, KYTC's Specifications shall be referenced. This item shall be paid LINEAR FEET (LF).

S FORCE MAIN This description shall apply to all PVC and ductile iron and polyethylene/plastic pipe bid items of every size and type, except those bid items defined as “Special”. This item includes the pipe specified by the plans and specifications, all fittings (including, but not limited to, bends, tees, reducers, plugs, and caps), tracing wire with test boxes (if required by specification), polyethylene wrap (when specified), labor, equipment, excavation, bedding, restoration, testing, backfill, and etc., required to install the specified new pipe and new fittings at the locations shown on the plans, or as directed, in accordance with the specifications and standard drawings complete and ready for use. No additional payment will be made for rock excavation. This bid item includes material and placement of flowable fill under existing and proposed pavement, and wherever else specified on the plans or in the specifications. This item shall also include pipe anchors on polyethylene pipe runs as shown on the plans or required by the specifications to prevent the creep or contraction of the pipe. Measurement of quantities under this item shall be through fittings, encasements, and directional bores (only when a separate carrier pipe is specified within the directional bore pipe). No separate payment will be made under pipe items when the directional bore pipe is the carrier pipe. Measurements shall be further defined to be to the center of tie-in where new pipe contacts existing pipe at the center of connecting fittings, to the outside face of vault or structure walls, or to the point of main termination at dead ends. Please refer to the Utility Company’s Specifications. If the Company does not have specifications, KYTC’s Specifications shall be referenced. This item shall be paid LINEAR FEET (LF).

S FORCE MAIN AIR RLS/VAC VLV This bid item description shall apply to all force main air release/vacuum valve installations of every size except those defined as “Special”. This item shall include the air release/vacuum valve, main to valve connecting line or piping, manhole/vault/structure, access casting or doors, tapping the main, labor, equipment, excavation, proper backfill and restoration required to install the air release/vacuum valve at the location shown on the plans or as directed in accordance with the specifications and standard drawings complete and ready for use. All air release/vacuum valves on a project shall be paid under one bid item regardless of size. No separate pay items will be established for size variations. Only in the case of the uniqueness of a particular air release/vacuum valve would a separate bid item be established. Please refer to the Utility Company’s Specifications. If the Company does not have specifications, KYTC’s Specifications shall be referenced. This item shall be paid EACH (EA) when complete.

S FORCE MAIN DIRECTIONAL BORE Payment under this item is made whenever the plans or specifications specifically show directional boring is to be utilized in order to minimize the impact of open cut for the installation of sewer or force main under streets, buildings, creeks, and etc. Payment under this item shall include the specified bore pipe, labor, and equipment. No separate payment shall be made for bore pipe installed in the bore whether used as a carrier pipe or an encasement of a separate carrier pipe. This item shall also include pipe anchors at each end of the bore when specified to prevent the creep or contraction of the bore pipe. Carrier pipe installed within a bore pipe shall be paid separately under pipe items. Payment under this item shall not be size specific and no separate bid items will be established for size variations. The bore pipe sizes to be included under this item shall be as shown on the plans and/or in the specifications. Any and all directional bores in each contract shall be paid under one directional bore bid item included in the contract regardless of size. Please refer to the Utility Company’s Specifications. If the Company does not have specifications, KYTC’s Specifications shall be referenced. This item shall be paid LINEAR FEET (LF).

S FORCE MAIN POINT RELOCATE This item is intended for payment for horizontal and/or vertical relocation of a short length of an existing main at the locations shown on the plans. This bid item is to be used to relocate an existing force main at point locations such as to clear a conflict at a

proposed drainage structure, pipe or any other similar short relocation situation, and where the existing pipe material is to be reused. The contractor shall provide any additional pipe or fitting material needed to complete the work as shown on the plans and specifications. The materials provided shall be of the same type and specification as those that exist. Substitution of alternative materials shall be approved by the engineer in advance on a case by case basis. New polyethylene wrap is to be provided (if wrap exists or is specified in the specifications to be used). If it is necessary that the pipe be disassembled for relay, payment under this item shall also include replacement of joint gaskets as needed. Bedding and backfill shall be provided and performed the same as with any other pipe installation as detailed in the plans and specifications. Payment under this item shall be for each location requiring an existing main to be relocated horizontally or vertically regardless of pipe size or relocation length. No separate pay items will be established for pipe size variations or relocation segment length variations. Force Main Relocate shall not be paid on a linear feet basis; but shall be shall be paid EACH (EA) at each location when complete and placed in service. Please refer to the Utility Company's Specifications. If the Company does not have specifications, KYTC's Specifications shall be referenced.

S FORCE MAIN TAP SLEVE/VALVE RANGE 1 OR 2 This item shall include the specified tapping sleeve, valve, valve box, concrete pad around valve box (when required in specifications or plans), labor, and equipment to install the specified tapping sleeve and valve, complete and ready for use in accordance with the plans and specifications. The size shall be the measured internal diameter of the live pipe to be tapped. The size tapping sleeve and valve to be paid under sizes 1 or 2 shall be as follows:

Range 1 = All live tapped main sizes up to and including 8 inches

Range 2 = All live tapped main sizes greater than 8 inches

Please refer to the Utility Company's Specifications. If the Company does not have specifications, KYTC's Specifications shall be referenced. This item shall be paid EACH (EA) when complete.

S FORCE MAIN TIE-IN This bid description shall be used for all force main tie-in bid items of every size except those defined as "Special". This item includes all labor, equipment, excavation, fittings, sleeves, reducers, couplings, blocking, anchoring, restoration, testing and backfill required to make the force main tie-in as shown on the plans and in accordance with the specifications complete and ready for use. This bid item shall include purge and sanitary disposal of any sewage from any abandoned segments of force main. Pipe for tie-ins shall be paid under separate bid items. Please refer to the Utility Company's Specifications. If the Company does not have specifications, KYTC's Specifications shall be referenced. This item shall be paid EACH (EA) when complete.

S FORCE MAIN VALVE This description shall apply to all force main valves of every size required in the plans and specifications, except those bid items defined as "Special". Payment under this description is to be for gate or butterfly force main valves being installed with new force main. This item includes the valve as specified in the plans and specifications, polyethylene wrap (if required by specification), labor, equipment, excavation, anchoring (if any), valve box and valve stem extensions, backfill, concrete pad around valve box (if required by specification), restoration, testing, and etc., required to install the specified valve at the location shown on the plans in accordance with the specifications and standard drawings complete and ready for use. If required on plans and/or proposed adjoining DIP is restrained, force main valves shall be restrained. Force main valve restraint shall be considered incidental to the force main valve and adjoining pipe. Please refer to the Utility Company's Specifications. If the Company does not have specifications, KYTC's Specifications shall be

referenced. This item shall be paid EACH (EA) when complete.

S FORCE MAIN VALVE BOX ADJUST Includes all labor, equipment, valve box and valve stem extensions (if required), excavation, backfill, concrete pad around valve box (when specified in specifications or plans), restoration, and etc., to adjust the top of the force main valve box to finished grade complete and ready for use. Please refer to the Utility Company's Specifications. If the Company does not have specifications, KYTC's Specifications shall be referenced. This item shall be paid EACH (EA) when complete.

S LATERAL CLEANOUT This item shall be for payment for installation of a cleanout in a service lateral line. This item shall include furnishing and installation of a tee, vertical pipe of whatever length required, and threaded cap. The cleanout shall extend from the lateral to final grade elevation. The size of the cleanout shall be equivalent to the size of the lateral. The cleanout materials shall meet the same specification as those for the lateral. The cleanout shall be installed at the locations shown on the plans or as directed by the engineer. Only one pay item shall be established for cleanout installation. No separate pay items shall be established for size or height variances. Please refer to the Utility Company's Specifications. If the Company does not have specifications, KYTC's Specifications shall be referenced. This item shall be paid EACH (EA) when complete.

S LATERAL LOCATE This bid item is to pay for all labor, equipment, and materials needed in locating an existing sanitary sewer service lateral for tie-in of the lateral to new mainline sewers and/or for the relocation of a lateral. This bid item shall be inclusive of any and all methods and efforts required to locate the lateral for tie-in or relocation of the lateral. Locating methods to be included under this items shall include, but are not limited to, those efforts employing the use of video cameras from within an existing sanitary sewer main or lateral, electronic locating beacons and/or tracers inserted into the sanitary sewer main or lateral, careful excavation as a separate operation from mainline sewer or lateral excavation, the use of dyes to trace the flow of a lateral, or any combination of methods required to accurately locate the lateral. Please refer to the Utility Company's Specifications. If the Company does not have specifications, KYTC's Specifications shall be referenced. This item shall be paid EACH (EA).

S LATERAL LONG SIDE This bid item description shall apply to all service lateral installations of every size up to and including 6 inch internal diameter, except those lateral bid items defined as "Special". This item includes the specified piping material, main tap, bends, clean outs, labor, equipment, excavation, backfill, testing, and restoration, at the locations shown on the plans or as directed, in accordance with the specifications and standard drawings, complete and ready for use. This bid item is to pay for service lateral installations where the ends of the lateral connection are on opposite sides of the public roadway. The new lateral must cross the centerline of the public roadway to qualify for payment as a long side lateral. The length of the service lateral is not to be specified. Payment under this item shall not be restricted by a minimum or maximum length. The contractor shall draw his own conclusions as to the length of piping that may be needed. Payment under this item shall include boring, jacking, or excavating across the public roadway for placement. Placement of a service lateral across a private residential or commercial entrance alone shall not be reason to make payment under this item. Private or commercial entrances shall not be considered a public roadway in defining payment under this item. No additional payment will be made for rock excavation or for bedding required in rock excavation. Please refer to the Utility Company's Specifications. If the Company does not have specifications, KYTC's Specifications shall be referenced. This item shall be paid EACH (EA) when complete.

S LATERAL SHORT SIDE This bid item description shall apply to all service lateral installations of every size up to and including 6 inch, except those lateral bid items defined as “Special”. This item includes the specified piping material, main tap tee, bends, clean outs, labor, equipment, excavation, backfill, testing, and restoration, at the locations shown on the plans or as directed, in accordance with the specifications and standard drawings, complete and ready for use. This bid item is to pay for lateral installations where both ends of the lateral connection are on the same side of the public roadway, or when an existing lateral crossing a public roadway will remain and is being extended, reconnected, or relocated with all work on one side of the public roadway centerline as shown on the plans. The length of the service lateral is not to be specified and shall not be restricted to any minimum or maximum length. Payment shall be made under this item even if the lateral crosses a private residential or commercial entrance; but, not a public roadway. Private or commercial entrances shall not be considered a public roadway in defining payment under this item. The contractor shall draw his own conclusions as to the length of piping that may be needed. No additional payment will be made for rock excavation or for bedding required in rock excavation. Please refer to the Utility Company’s Specifications. If the Company does not have specifications, KYTC’s Specifications shall be referenced. This item shall be paid EACH (EA) when complete.

S LINE MARKER This item is for payment for furnishing and installing a sewer utility line marker as specified by the utility owner specifications and plans. A line marker may consist of a post or monument of whatever materials specified and shall include markings and/or signage on same as specified by plans or specifications. This item shall include all labor, equipment, and materials needed for complete installation of the marker. This item shall be paid EACH (EA) when complete.

S MANHOLE Payment under this item is for the installation of new 4 foot interior diameter sanitary sewer manhole. Payment for manholes will be made at the contract unit price each in place complete and ready for use at the locations shown on plans in accordance with specifications and standard drawings. Manholes shall include concrete base, barrel sections, cone section or slab top, steps, excavation, backfilling, air testing, restoration, and cleanup in accordance with the specifications and standard drawings. Payment shall be made under this item regardless of whether the base is to be precast or cast-in-place (doghouse). All materials, except casting, shall be new and unused. An existing casting from an existing abandoned or removed manhole is to be reused and shall be considered incidental to this item. When a new casting is specified, or an existing casting is unavailable, it shall be paid as a separate bid item. Anchoring of casting, new or used, shall be considered incidental to this bid item. No additional compensation will be paid for manhole height variations. No additional payment will be made for rock excavation. Please refer to the Utility Company’s Specifications. If the Company does not have specifications, KYTC’s Specifications shall be referenced. This item shall be paid EACH (EA) when complete.

S MANHOLE ABANDON/REMOVE Payment under this item is for the partial removal and/or filling of any sanitary sewer manhole regardless of size or depth that no longer serves any purpose. Payment shall be made regardless of whether the manhole is or is not in conflict with other work. Any manhole requiring partial removal, but not total removal, in order to clear a conflict with other work shall be paid under this item. All manholes partially removed shall be removed to a point at least one foot below final grade, one foot below roadway subgrade, or one foot clear of any other underground infrastructure, whichever is lowest. If partial removal of an abandoned manhole is elected by the contractor, the remaining manhole structure shall be refilled with flowable fill. Payment for disposal of a sanitary sewer manhole will be made under this item only. Please refer to the Utility Company’s

Specifications. If the Company does not have specifications, KYTC's Specifications shall be referenced. This item shall be paid EACH (EA) when complete.

S MANHOLE ADJUST TO GRADE Payment under this item is for the adjustment of sanitary sewer casting elevation on all sizes of existing sanitary manholes. This work shall be performed in accordance with the sanitary sewer specifications. Payment shall be made under this bid item regardless of the amount of adjustment necessary to a sanitary sewer manhole casting or diameter of the manhole. Work under this pay item may be as simple as placing a bed of mortar under a casting; but, shall also be inclusive of installation of adjusting rings, and /or addition, removal, or replacement of barrel sections. The existing casting is to be reused unless a new casting is specified on the plans. New casting, when specified, shall be paid as a separate bid item. Anchoring of the casting shall be incidental to this item. Please refer to the Utility Company's Specifications. If the Company does not have specifications, KYTC's Specifications shall be referenced. This item shall be paid EACH (EA) when complete.

S MANHOLE CASTING STANDARD Payment under this bid items is for furnishing of a new standard traffic baring casting for sanitary manholes meeting the requirements of the sanitary sewer specifications and standard drawings. Please refer to the Utility Company's Specifications. If the Company does not have specifications, KYTC's Specifications shall be referenced. This item shall be paid EACH (EA) when installed.

S MANHOLE CASTING WATERTIGHT Payment under this bid item is for furnishing of a new watertight traffic baring casting for sanitary manholes meeting the requirements of the sanitary sewer specifications and standard drawings. Please refer to the Utility Company's Specifications. If the Company does not have specifications, KYTC's Specifications shall be referenced. This item shall be paid EACH (EA) when installed.

S MANHOLE RECONSTRUCT INVERT This bid item is to pay for all labor, equipment, and material for rework of the manhole bench to redirect or eliminate flow, such as when the flow of a pipe or pipes are being removed or redirected. This work will be as specified in the plans, specifications, or directed by the engineer. This work may consist of, but is not limited to, removal of concrete and/or placement of concrete in elimination or redirect of flow. This item shall also include providing and placement of a rubber seal or boot as required by utility specification, standard drawing or plan. The contractor shall draw his own conclusions as to the effort and scope of work needed to comply with the specifications, standard drawings, and plans. No payment shall be made under this bid when MANHOLE TAP EXISTING, or MANHOLE TAP EXISTING ADD DROP are being paid at the same location, as this type of work is included in those items. Please refer to the Utility Company's Specifications. If the Company does not have specifications, KYTC's Specifications shall be referenced. This item shall be paid EACH (EA) when complete.

S MANHOLE TAP EXISTING This bid item is to pay for all labor, equipment, and material for coring one opening in an existing manhole base, addition of a rubber seal as specified, and rework of the manhole bench to direct the additional pipe flow. The bid item shall be paid for each core opening added to a single manhole. This bid item shall also include any rework of the existing manhole bench due to the elimination of other existing pipes and flow. This work will be as specified in the plans, specifications, or directed by the engineer. This work may consist of, but is not limited to, removal of concrete and/or placement of concrete in the addition, elimination, or redirect of flow. The contractor shall draw his own conclusions as to the effort and scope of work needed to comply with the

specifications, standard drawings, and plans. Please refer to the Utility Company's Specifications. If the Company does not have specifications, KYTC's Specifications shall be referenced. This item shall be paid EACH (EA) when complete.

S MANHOLE TAP EXISTING ADD DROP This bid item is to pay for all labor, equipment, and material for coring one opening in an existing manhole base, addition of a rubber seal as specified, addition of a vertical drop pipe to the outside of the manhole, placement of reinforcing steel and concrete to encase vertical pipe, and rework of the manhole bench to direct the additional pipe flow. The bid item shall be paid for each drop added to a single manhole. This bid item shall also include any rework of the existing manhole bench due to the elimination of other existing pipes and flow. This work will be as specified in the plans, specifications, or directed by the engineer. This work may consist of, but is not limited to, removal of concrete and/or placement of concrete in the addition, elimination, or redirect of flow. The contractor shall draw his own conclusions as to the effort and scope of work needed to comply with the specifications, standard drawings, and plans. Please refer to the Utility Company's Specifications. If the Company does not have specifications, KYTC's Specifications shall be referenced. This item shall be paid EACH (EA) when complete.

S MANHOLE WITH DROP Payment under this item is for the installation of new 4 foot interior diameter sanitary sewer manhole with drop. Payment for drop manholes will be made at the contract unit price each in place complete and ready for use at the locations shown on plans in accordance with specifications and standard drawings. Drop manholes shall include concrete base, barrel sections, drop materials, cone section or slab top, steps, excavation, backfilling, air testing, restoration, and cleanup. Payment shall be made under this item regardless of whether the base is to be precast or cast-in-place (doghouse). All materials, except casting, shall be new and unused. An existing casting from an existing abandoned or removed manhole is to be reused and shall be considered incidental to this item. When a new casting is specified, or an existing casting is unavailable, it shall be paid as a separate bid item. Anchoring of casting, new or used, shall be considered incidental to this bid item. No additional compensation will be paid for manhole height variations. No additional payment will be made for rock excavation. Please refer to the Utility Company's Specifications. If the Company does not have specifications, KYTC's Specifications shall be referenced. This item shall be paid EACH (EA) when complete.

S MANHOLE WITH LINING Payment under this item is for the installation of new 4 foot interior diameter sanitary sewer manhole with corrosion resistant lining. Payment for manholes will be made at the contract unit price each in place complete and ready for use at the locations shown on plans in accordance with specifications and standard drawings. Manholes shall include concrete base, barrel sections, cone section or slab top, steps, lining, excavation, backfilling, air testing, restoration, and cleanup in accordance with the standard drawings. Payment shall be made under this item regardless of whether the base is to be precast or cast-in-place (doghouse). All materials, except casting, shall be new and unused. An existing casting from an existing abandoned or removed manhole is to be reused and shall be considered incidental to this item. When a new casting is specified, or an existing casting is unavailable, it shall be paid as a separate bid item. Anchoring of casting, new or used, shall be considered incidental to this bid item. No additional compensation will be paid for manhole height variations. No additional payment will be made for rock excavation. Please refer to the Utility Company's Specifications. If the Company does not have specifications, KYTC's Specifications shall be referenced. This item shall be paid EACH (EA) when complete.

S MANHOLE WITH TRAP Payment under this item is for the installation of a new manhole with

trap. Payment for trap manholes will be made at the contract unit price each in place complete and ready for use at the locations shown on plans in accordance with specifications and standard drawings. Trap manholes shall include concrete base, manhole structure and trap materials, cone section or slab top, steps, excavation, backfilling, air testing, restoration, and cleanup. All materials, except casting, shall be new and unused. Payment shall be made under this item regardless of whether the base is to be precast or cast-in-place (doghouse). An existing casting from an existing abandoned or removed manhole is to be reused and shall be considered incidental to this item. When a new casting is specified, or an existing casting is unavailable, it shall be paid as a separate bid item. Anchoring of casting, new or used, shall be considered incidental to this bid item. No additional compensation will be paid for manhole height variations. No additional payment will be made for rock excavation. Please refer to the Utility Company's Specifications. If the Company does not have specifications, KYTC's Specifications shall be referenced. This item shall be paid EACH (EA) when complete.

S PIPE This description shall apply to all PVC and ductile iron gravity sewer pipe bid items of every size and type 8 inches internal diameter and larger, except those bid items defined as "Special". This item includes the pipe specified by the plans and specifications, all fittings (including, but not limited to, tap tees and couplings for joining to existing similar or dissimilar pipes), polyethylene wrap (if required by specification), labor, equipment, excavation, bedding, restoration, pressure or vacuum testing, temporary testing materials, video inspection, backfill, and etc., required to install the specified new pipe and new fittings at the locations shown on the plans, or as directed, in accordance with the specifications and standard drawings complete and ready for use. This bid item shall include material and placement of flowable fill under existing and proposed pavement, and wherever specified on the plans or in the specifications. No additional payment will be made for rock excavation. Measurement of quantities under this item shall be through fittings and encasements to a point at the outside face of manhole barrels, or to the point of main termination at dead ends or lamp holes. Carrier pipe placed within an encasement shall be paid under this item and shall include casing spacers and end seals. Please refer to the Utility Company's Specifications. If the Company does not have specifications, KYTC's Specifications shall be referenced. This item shall be paid LINEAR FEET (LF).

S PIPE POINT REPAIR This item is to be used to pay for repair of short lengths of existing sanitary sewer pipe that, through prior video inspection or other means, are known to have pre-existing failure. Pipe Point Repair may be needed in preparation for installation of cured-in-place-pipe (CIPP) lining or other instances where failure is known and repair is prudent. The size of pipe shall not be defined in separate bid items. All diameter sizes of point repair shall be paid under this one item. The materials to be used to make the repair shall be as defined on the plans or in the specifications. This bid item shall include all excavation, pipe materials, joining materials to connect old and new pipe, bedding, and backfill to complete the repair at the locations shown on the plans or as directed by the engineer, complete and ready for use. This bid item shall include bypass pumping when required. Measurement shall be from contact point to contact point of old and new pipe. Please refer to the Utility Company's Specifications. If the Company does not have specifications, KYTC's Specifications shall be referenced. This item shall be paid LINEAR FEET (LF).

S PUMP STATION This item is for payment for installation of sanitary pump stations including above or below ground structure for housing of the pumps. This item shall include all pumps, piping, fittings, valves, electrical components, building materials, concrete, any other appurtenances, labor, equipment, excavation, and backfill, to complete the pump station installation as required by the plans, standard drawings, and specifications, complete and ready for use. Please refer to the Utility Company's Specifications. If the Company does not have specifications, KYTC's Specifications shall

be referenced. This item shall be paid LUMP SUM (LS) for each when complete.

S STRUCTURE ABANDON This item is to be used to pay for abandonment of larger above or below ground sewer structures such as air release/vacuum valve vaults, pump stations, tanks, etc. Payment under this time shall not be limited to size or scope; however structures with connecting pipes of 2 inches or less shall not be paid under this item; but, shall be considered incidental to sewer construction, (i.e., abandonment of standard air release/vacuum valves up to and including 2 inches would not be paid under this item). Payment under this item shall include all labor, equipment, and compacted fill or flowable fill for abandonment of the structure in place and restoration complete. No separate bid items will be established for size or structure variations. Please refer to the Utility Company's Specifications. If the Company does not have specifications, KYTC's Specifications shall be referenced. This item shall be paid EACH (EA) when complete.

S STRUCTURE REMOVAL This item is to be used to pay for removal of larger above or below ground sewer structures such as air release/vacuum valve vaults, pump stations, tanks, and etc. Payment under this time shall not be limited to size or scope; however, structures with connecting pipes of 2 inches or less shall not be paid under this item; but, shall be considered incidental to sewer construction, (i.e., removal of standard air release/vacuum valves and their structure up to and including 2 inches would not be paid under this item). Payment under this item shall include all labor, equipment, and compacted backfill for removal of the structure and restoration complete. No separate bid items will be established for size or structure variations. Please refer to the Utility Company's Specifications. If the Company does not have specifications, KYTC's Specifications shall be referenced. This item shall be paid EACH (EA) when complete.

KyTC BMP Plan for Project CID ## - #####



Kentucky Transportation Cabinet

Highway District 11

And

_____ **(2), Construction**

**Kentucky Pollutant Discharge Elimination System
Permit KYR10**

Best Management Practices (BMP) plan

Groundwater protection plan

For Highway Construction Activities

For

US 25E Reconstruction

Project: CID ## - #####

KyTC BMP Plan for Project CID ## -

Project information

Note – (1) = Design (2) = Construction (3) = Contractor

1. Owner – Kentucky Transportation Cabinet, District 11
2. Resident Engineer: (2)
3. Contractor name: (2)
Address: (2)

Phone number: (2)
Contact: (2)
Contractors agent responsible for compliance with the KPDES permit requirements (3):
4. Project Control Number (2)
5. Route (Address) US-25E
6. Latitude/Longitude (project mid-point) 36°58'26.33"N, 84° 5'58.49"W
7. County (project mid-point) Laurel
8. Project start date (date work will begin): (2)
9. Projected completion date: (2)

KyTC BMP Plan for Project CID ## -

A. Site description:

1. Nature of Construction Activity: Improve Safety, Improve Access Management, and Reduce Congestion on US-25E From The Knox/Laurel County Line To KY-770
2. Order of major soil disturbing activities (2) and (3)
3. Projected volume of material to be moved: Cut: 80,225 CUYD, Fill: 61,203 CUYD, and Waste: 19,022 CUYD.
4. Estimate of total project area (acres) 115.36 Acres
5. Estimate of area to be disturbed (acres) 78.75 Acres
6. Post construction runoff coefficient will be included in the project drainage folder. Persons needing information pertaining to the runoff coefficient will contact the resident engineer to request this information. (2)
7. Data describing existing soil condition (1) & (2)
8. Data describing existing discharge water quality (if any) (1) & (2)
9. Receiving water name: Horse Creek, Lynn Camp Creek, and Laurel River
10. TMDLs and Pollutants of Concern in Receiving Waters: No Pollutants of concern listed for Horse Creek. Nutrient/Eutrophication, Oil and Grease, Organic Enrichment (Sewage), Total Suspended Solids, and Pathogens are listed as pollutants/areas of concern for Lynn Camp Creek. No Pollutants of are concern listed for Laurel River. No TMDLs are given for the pollutants of concern in Lynn Camp Creek. This project is not expected to generate these pollutants.
11. Site map – Project layout sheet plus the erosion control sheets in the project plans that depict Disturbed Drainage Areas (DDAs) and related information. These sheets depict the existing project conditions with areas delineated by DDA (drainage area bounded by watershed breaks and right of way limits), the storm water discharge locations (either as a point discharge or as overland flow) and the areas that drain to each discharge point. These plans define the limits of areas to be disturbed and the location of control measures. Controls will be either site specific as designated by the designer or will be annotated by the contractor and resident engineer before disturbance commences. The project layout sheet shows the surface waters and wetlands.

KyTC BMP Plan for Project CID ## -

12. Potential sources of pollutants:

The primary source of pollutants is solids that are mobilized during storm events. Other sources of pollutants include oil/fuel/grease from servicing and operating construction equipment, concrete washout water, sanitary wastes and trash/debris. (3)

B. Sediment and Erosion Control Measures:

1. Plans for highway construction projects will include erosion control sheets that depict Disturbed Drainage Areas (DDAs) and related information. These plan sheets will show the existing project conditions with areas delineated by DDA within the right of way limits, the discharge points and the areas that drain to each discharge point. Project managers and designers will analyze the DDAs and identify Best Management Practices (BMPs) that are site specific. The balance of the BMPs for the project will be listed in the bid documents for selection and use by the contractor on the project with approval by the resident engineer.

Projects that do not have DDAs annotated on the erosion control sheets will employ the same concepts for development and managing BMP plans.

2. Following award of the contract, the contractor and resident engineer will annotate the erosion control sheets showing location and type of BMPs for each of the DDAs that will be disturbed at the outset of the project. This annotation will be accompanied by an order of work that reflects the order or sequence of major soil moving activities. The remaining DDAs are to be designated as "Do Not Disturb" until the contractor and resident engineer prepare the plan for BMPs to be employed. The initial BMP's shall be for the first phase (generally Clearing and Grubbing) and shall be modified as needed as the project changes phases. The BMP Plan will be modified to reflect disturbance in additional DDA's as the work progresses. All DDA's will have adequate BMP's in place before being disturbed.
3. As DDAs are prepared for construction, the following will be addressed for the project as a whole or for each DDA as appropriate:
 - Construction Access – This is the first land-disturbing activity. As soon as construction begins, bare areas will be stabilized with gravel and temporary mulch and/or vegetation.

KyTC BMP Plan for Project CID ## -

- At the beginning of the project, all DDAs for the project will be inspected for areas that are a source of storm water pollutants. Areas that are a source of pollutants will receive appropriate cover or BMPs to arrest the introduction of pollutants into storm water. Areas that have not been opened by the contractor will be inspected periodically (once per month) to determine if there is a need to employ BMPs to keep pollutants from entering storm water.
- Clearing and Grubbing – The following BMP's will be considered and used where appropriate.
 - Leaving areas undisturbed when possible.
 - Silt basins to provide silt volume for large areas.
 - Silt Traps Type A for small areas.
 - Silt Traps Type C in front of existing and drop inlets which are to be saved
 - Diversion ditches to catch sheet runoff and carry it to basins or traps or to divert it around areas to be disturbed.
 - Brush and/or other barriers to slow and/or divert runoff.
 - Silt fences to catch sheet runoff on short slopes. For longer slopes, multiple rows of silt fence may be considered.
 - Temporary Mulch for areas which are not feasible for the fore mentioned types of protections.
 - Non-standard or innovative methods.
- Cut & Fill and placement of drainage structures - The BMP Plan will be modified to show additional BMP's such as:
 - Silt Traps Type B in ditches and/or drainways as they are completed
 - Silt Traps Type C in front of pipes after they are placed
 - Channel Lining
 - Erosion Control Blanket
 - Temporary mulch and/or seeding for areas where construction activities will be ceased for 21 days or more.
 - Non-standard or innovative methods
- Profile and X-Section in place – The BMP Plan will be modified to show elimination of BMP's which had to be removed and the addition of new BMP's as the roadway was shaped. Probably changes include:
 - Silt Trap Type A, Brush and/or other barriers, Temporary Mulch, and any other BMP which had to be removed for final grading to take place.
 - Additional Silt Traps Type B and Type C to be placed as final drainage patterns are put in place.
 - Additional Channel Lining and/or Erosion Control Blanket.
 - Temporary Mulch for areas where Permanent Seeding and Protection cannot be done within 21 days.
 - Special BMP's such as Karst Policy

KyTC BMP Plan for Project CID ## -

- Finish Work (Paving, Seeding, Protect, etc.) – A final BMP Plan will result from modifications during this phase of construction. Probably changes include:
 - Removal of Silt Traps Type B from ditches and drainways if they are protected with other BMP's which are sufficient to control erosion, i.e. Erosion Control Blanket or Permanent Seeding and Protection on moderate grades.
 - Permanent Seeding and Protection
 - Placing Sod
 - Planting trees and/or shrubs where they are included in the project
- BMP's including Storm Water Management Devices such as velocity dissipation devices and Karst policy BMP's to be installed during construction to control the pollutants in storm water discharges that will occur after construction has been completed are: **Permanent Seeding and Protection, Channel Lining.**

C. Other Control Measures

1. No solid materials, including building materials, shall be discharged to waters of the commonwealth, except as authorized by a Section 404 permit.
2. Waste Materials

All waste materials that may leach pollutants (paint and paint containers, caulk tubes, oil/grease containers, liquids of any kind, soluble materials, etc.) will be collected and stored in appropriate covered waste containers. Waste containers shall be removed from the project site on a sufficiently frequent basis as to not allow wastes to become a source of pollution. All personnel will be instructed regarding the correct procedure for waste disposal. Wastes will be disposed in accordance with appropriate regulations. Notices stating these practices will be posted in the office.

3. Hazardous Waste

All hazardous waste materials will be managed and disposed of in the manner specified by local or state regulation. The contractor shall notify the Section Engineer if there any hazardous wastes being generated at the project site and how these wastes are being managed. Site personnel will be instructed with regard to proper storage and handling of hazardous wastes when required. The Transportation Cabinet will file for generator, registration when appropriate, with the Division of Waste Management and advise the contractor regarding waste management requirements.

KyTC BMP Plan for Project CID ## -

4. Spill Prevention

The following material management practices will be used to reduce the risk of spills or other exposure of materials and substances to the weather and/or runoff.

➤ **Good Housekeeping:**

The following good housekeeping practices will be followed onsite during the construction project.

- An effort will be made to store only enough product required to do the job
- All materials stored onsite will be stored in a neat, orderly manner in their appropriate containers and, if possible, under a roof or other enclosure
- Products will be kept in their original containers with the original manufacturer's label
- Substances will not be mixed with one another unless recommended by the manufacturer
- Whenever possible, all of the product will be used up before disposing of the container
- Manufacturers' recommendations for proper use and disposal will be followed
- The site contractor will inspect daily to ensure proper use and disposal of materials onsite

➤ **Hazardous Products:**

These practices will be used to reduce the risks associated with any and all hazardous materials.

- Products will be kept in original containers unless they are not resealable
- Original labels and material safety data sheets (MSDS) will be reviewed and retained
- Contractor will follow procedures recommended by the manufacturer when handling hazardous materials
- If surplus product must be disposed of, manufacturers' or state/local recommended methods for proper disposal will be followed

The following product-specific practices will be followed onsite:

➤ **Petroleum Products:**

KyTC BMP Plan for Project CID ## -

Vehicles and equipment that are fueled and maintained on site will be monitored for leaks, and receive regular preventative maintenance to reduce the chance of leakage. Petroleum products onsite will be stored in tightly sealed containers, which are clearly labeled and will be protected from exposure to weather.

The contractor shall prepare an Oil Pollution Spill Prevention Control and Countermeasure plan when the project that involves the storage of petroleum products in 55 gallon or larger containers with a total combined storage capacity of 1,320 gallons. This is a requirement of 40 CFR 112.

This project (will / will not) (3) have over 1,320 gallons of petroleum products with a total capacity, sum of all containers 55 gallon capacity and larger.

➤ **Fertilizers:**

Fertilizers will be applied at rates prescribed by the contract, standard specifications or as directed by the resident engineer. Once applied, fertilizer will be covered with mulch or blankets or worked into the soil to limit exposure to storm water. Storage will be in a covered shed. The contents of any partially used bags of fertilizer will be transferred to a sealable plastic bin to avoid spills.

➤ **Paints:**

All containers will be tightly sealed and stored indoors or under roof when not being used. Excess paint or paint wash water will not be discharged to the drainage or storm sewer system but will be properly disposed of according to manufacturers' instructions or state and local regulations.

➤ **Concrete Truck Washout:**

Concrete truck mixers and chutes will not be washed on pavement, near storm drain inlets, or within 75 feet of any ditch, stream, wetland, lake, or sinkhole. Where possible, excess concrete and wash water will be discharged to areas prepared for pouring new concrete, flat areas to be paved that are away from ditches or drainage system features, or other locations that will not drain off site. Where this approach is not possible, a shallow earthen wash basin will be excavated away from ditches to receive the wash water

➤ **Spill Control Practices**

In addition to the good housekeeping and material management practices discussed in the previous sections of this plan, the following practices will be followed for spill prevention and cleanup:

KyTC BMP Plan for Project CID ## -

- Manufacturers' recommended methods for spill cleanup will be clearly posted. All personnel will be made aware of procedures and the location of the information and cleanup supplies.
- Materials and equipment necessary for spill cleanup will be kept in the material storage area. Equipment and materials will include as appropriate, brooms, dust pans, mops, rags, gloves, oil absorbents, sand, sawdust, and plastic and metal trash containers.
- All spills will be cleaned up immediately after discovery.
- The spill area will be kept well ventilated and personnel will wear appropriate protective clothing to prevent injury from contact with a hazardous substance.
- Spills of toxic or hazardous material will be reported to the appropriate state/local agency as required by KRS 224 and applicable federal law.
- The spill prevention plan will be adjusted as needed to prevent spills from reoccurring and improve spill response and cleanup.
- Spills of products will be cleaned up promptly. Wastes from spill clean up will be disposed in accordance with appropriate regulations.

D. Other State and Local Plans

This BMP plan shall include any requirements specified in sediment and erosion control plans, storm water management plans or permits that have been approved by other state or local officials. Upon submittal of the NOI, other requirements for surface water protection are incorporated by reference into and are enforceable under this permit (even if they are not specifically included in this BMP plan). This provision does not apply to master or comprehensive plans, non-enforceable guidelines or technical guidance documents that are not identified in a specific plan or permit issued for the construction site by state or local officials. **Not Applicable**

E. Maintenance

1. The BMP plan shall include a clear description of the maintenance procedures necessary to keep the control measures in good and effective operating condition.
- Maintenance of BMPs during construction shall be a result of weekly and post rain event inspections with action being taken by the contractor to correct deficiencies.
 - Post Construction maintenance will be a function of normal highway maintenance operations. Following final project acceptance by the cabinet, district highway crews will be responsible for identification and correction of deficiencies regarding ground cover and cleaning of storm water BMPs. The project manager shall identify any BMPs that will be for

KyTC BMP Plan for Project CID ## -

the purpose of post construction storm water management with specific guidance for any non-routine maintenance. **Not Applicable**

F. Inspections

Inspection and maintenance practices that will be used to maintain erosion and sediment controls:

- All erosion prevention and sediment control measures will be inspected at least once each week and following any rain of one-half inch or more.
- Inspections will be conducted by individuals that have successfully completed the KEPSC-RI course as required by Section 213.02.02 of the Standard Specifications for Road and Bridge Construction, current edition.
- Inspection reports will be written, signed, dated, and kept on file.
- Areas at final grade will be seeded and mulched within 14 days.
- Areas that are not at final grade where construction has ceased for a period of 21 days or longer and soil stock piles shall receive temporary mulch no later than 14 days from the last construction activity in that area.
- All measures will be maintained in good working order; if a repair is necessary, it will be initiated within 24 hours of being reported.
- Built-up sediment will be removed from behind the silt fence before it has reached halfway up the height of the fence.
- Silt fences will be inspected for bypassing, overtopping, undercutting, depth of sediment, tears, and to ensure attachment to secure posts.
- Sediment basins will be inspected for depth of sediment, and built-up sediment will be removed when it reaches 50 percent of the design capacity and at the end of the job.
- Diversion dikes and berms will be inspected and any breaches promptly repaired. Areas that are eroding or scouring will be repaired and re-seeded / mulched as needed.
- Temporary and permanent seeding and mulching will be inspected for bare spots, washouts, and healthy growth. Bare or eroded areas will be repaired as needed.
- All material storage and equipment servicing areas that involve the management of bulk liquids, fuels, and bulk solids will be inspected weekly for conditions that represent a release or possible release of pollutants to the environment.

KyTC BMP Plan for Project CID ## - #####

G. Non – Storm Water discharges

It is expected that non-storm water discharges may occur from the site during the construction period. Examples of non-storm water discharges include:

- Water from water line flushings.
- Water form cleaning concrete trucks and equipment.
- Pavement wash waters (where no spills or leaks of toxic or hazardous materials have occurred).
- Uncontaminated groundwater and rain water (from dewatering during excavation).

All non-storm water discharges will be directed to the sediment basin or to a filter fence enclosure in a flat vegetated infiltration area or be filtered via another approved commercial product.

H. Groundwater Protection Plan (3)

This plan serves as the groundwater protection plan as required by 401 KAR 5:037.

- Contractors statement: (3)

The following activities, as enumerated by 401 KAR 5:037 Section 2 that require the preparation and implementation of a groundwater protection plan, will or may be may be conducted as part of this construction project:

_____ 2. (e) land treatment or land disposal of a pollutant;

_____ 2. (f) Storing, ..., or related handling of hazardous waste, solid waste or special waste, ..., in tanks, drums, or other containers, or in piles, (This does not include wastes managed in a container placed for collection and removal of municipal solid waste for disposal off site);

_____ 2. (g) Handling of materials in bulk quantities (equal or greater than 55 gallons or 100 pounds net dry weight transported held in an individual container) that, if released to the environment, would be a pollutant;

_____ 2. (j) Storing or related handling of road oils, dust suppressants,, at a central location;

KyTC BMP Plan for Project CID ## - #####

_____ 2. (k) Application or related handling of road oils, dust suppressants or deicing materials, (does not include use of chloride-based deicing materials applied to roads or parking lots);

_____ 2. (m) Installation, construction, operation, or abandonment of wells, bore holes, or core holes, (this does not include bore holes for the purpose of explosive demolition);

Or, check the following only if there are no qualifying activities

_____ There are no activities for this project as listed in 401 KAR 5:037 Section 2 that require the preparation and implementation of a groundwater protection plan.

The contractor is responsible for the preparation of a plan that addresses the

401 KAR 5:037 Section 3. (3) Elements of site specific groundwater protection plan:

- (a) General information about this project is covered in the Project information;
- (b) Activities that require a groundwater protection plan have been identified above;
- (c) Practices that will protect groundwater from pollution are addressed in section C. Other control measures.
- (d) Implementation schedule – all practices required to prevent pollution of groundwater are to be in place prior to conducting the activity;
- (e) Training is required as a part of the ground water protection plan. All employees of the contractor, sub-contractor and resident engineer personnel will be trained to understand the nature and requirements of this plan as they pertain to their job function(s). Training will be accomplished within one week of employment and annually thereafter. A record of training will be maintained by the contractor with a copy provide to the resident engineer.
- (f) Areas of the project and groundwater plan activities will be inspected as part of the weekly sediment and erosion control inspections
- (g) Certification (see signature page.)

KyTC BMP Plan for Project CID ## -

Contractor and Resident Engineer Plan certification

The contractor that is responsible for implementing this BMP plan is identified in the Project Information section of this plan.

The following certification applies to all parties that are signatory to this BMP plan:

I certify under penalty of law that this document and all attachments were prepared under my direction or supervision in accordance with a system designed to assure that qualified personnel properly gathered and evaluated the information submitted. Based on my inquiry of the person or persons who manage the system, or those persons directly responsible for gathering the information, the information submitted is, to the best of my knowledge and belief, true, accurate, and complete. I am aware that there are significant penalties for submitting false information, including the possibility of fine and imprisonment for knowing violations. Further, this plan complies with the requirements of 401 KAR 5:037. By this certification, the undersigned state that the individuals signing the plan have reviewed the terms of the plan and will implement its provisions as they pertain to ground water protection.

Resident Engineer and Contractor Certification:

(2) Resident Engineer signature

Signed _____ title _____, _____ signature
 Typed or printed name²

(3) Signed _____ title _____, _____ signature
 Typed or printed name¹

1. Contractors Note: to be signed by a person who is the owner, a responsible corporate officer, a general partner or the proprietor or a person designated to have the authority to sign reports by such a person in accordance with 401 KAR 5:060 Section 9. This delegation shall be in writing to: Manager, KPDES Branch, Division of Water, 14 Reilly Road, Frankfort Kentucky 40601. Reference the Project Control Number (PCN) and KPDES number when one has been issued.

2. KyTC note: to be signed by the Chief District Engineer or a person designated to have the authority to sign reports by such a person (usually the resident engineer) in accordance with 401 KAR 5:060 Section 9. This delegation shall be in writing to: Manager, KPDES Branch, Division of Water, 14 Reilly Road, Frankfort Kentucky 40601 Reference the Project Control Number (PCN) and KPDES number when one has been issued.

KyTC BMP Plan for Project CID ## - #####

Sub-Contractor Certification

The following sub-contractor shall be made aware of the BMP plan and responsible for implementation of BMPs identified in this plan as follows:

Subcontractor

Name:
Address:
Address:

Phone:

The part of BMP plan this subcontractor is responsible to implement is:

I certify under penalty of law that I understand the terms and conditions of the general Kentucky Pollutant Discharge Elimination System permit that authorizes the storm water discharges, the BMP plan that has been developed to manage the quality of water to be discharged as a result of storm events associated with the construction site activity and management of non-storm water pollutant sources identified as part of this certification.

Signed _____ title _____, _____
Typed or printed name¹ signature

1. Sub Contractor Note: to be signed by a person who is the owner, a responsible corporate officer, a general partner or the proprietor or a person designated to have the authority to sign reports by such a person in accordance with 401 KAR 5:060 Section 9. This delegation shall be in writing to: Manager, KPDES Branch, Division of Water, 14 Reilly Road, Frankfort Kentucky 40601. Reference the Project Control Number (PCN) and KPDES number when one has been issued.



ANDY BESHEAR
GOVERNOR

REBECCA W. GOODMAN
SECRETARY

ENERGY AND ENVIRONMENT CABINET
DEPARTMENT FOR ENVIRONMENTAL PROTECTION

ANTHONY R. HATTON
COMMISSIONER

300 SOWER BOULEVARD
FRANKFORT, KENTUCKY 40601

May 24, 2022

Chris Jones
KYTC District 11
603 Railroad Ave
Manchester, KY 40962

Re: KYR10 Coverage Acknowledgment
KPDES No.: KYR10Q367
11-0185 US-25E Widening
Permit Type: Construction
AI ID: 70921
Laurel County, Kentucky

Dear Chris Jones :

The discharges associated with the Notice of Intent you submitted have been approved for coverage under the "Kentucky Pollutant Discharge Elimination System (KPDES) General Permit for Storm Water Discharges Associated with Construction Activities (KYR100000)" master general permit. Your coverage becomes effective on the date of this letter, and will automatically terminate two years from the effective date of your coverage unless an extension is requested prior to the termination date, until the KYR100000 master general permit expires on November 30, 2024, or the Division of Water revokes coverage, whichever comes first. During this period of coverage all discharges shall comply with the conditions of the KYR100000 master general permit. This permit and links to the eNOI (and permit coverage extension) and eNOT forms can be found on our website:

<https://eec.ky.gov/Environmental-Protection/Water/PermitCert/KPDES/Documents/KYR10PermitPage.pdf>.

Any person aggrieved by the issuance of a permit final decision may demand a hearing pursuant to KRS 224.10-420(2) within thirty (30) days from the date of the issuance of this letter. Any demand for a hearing on the permit shall be filed in accordance with the procedures specified in KRS 224.10-420, 224.10-440, 224.10-470, and the regulations promulgated thereto. The request for hearing should be submitted in writing to the Energy and Environment Cabinet, Office of Administrative Hearings, 211 Sower Boulevard, Frankfort, Kentucky 40601 and the Commonwealth of Kentucky, Energy and Environment Cabinet, Division of Water, 300 Sower Boulevard, Frankfort, Kentucky 40601. For your record keeping purposes, it is recommended that these requests be sent by certified mail. The written request must conform to the appropriate statutes referenced above.

Any questions concerning the general permit and its requirements should be directed to me at 502-782-7123 or email me at Karina.Villanueva@ky.gov

Construction Site GPS Coordinates: 36.974333, -84.100603
Receiving Water: Lynn Camp Creek

Sincerely,

Karina Villanueva
Surface Water Permits Branch
Division of Water

cc: Joshua Higgins, eNOI Preparer
Robert Miller, London Regional Office
Shawn Hokanson, Division of Water



Thank you for submitting your information via the Kentucky Department for Environmental Protection eForms website. Please save a copy of this submittal for your records. We recommend saving a copy as a .mht, .html, or .htm file. The Submittal ID for this transaction is 291600 and was submitted on May 04, 2022 08:55 AM Eastern Time. If you need to contact EEC regarding your submission, please reference your Submittal ID.

The eForm Submittal ID allows you to use the data from this submittal as a template and/or download a copy of your submittal.

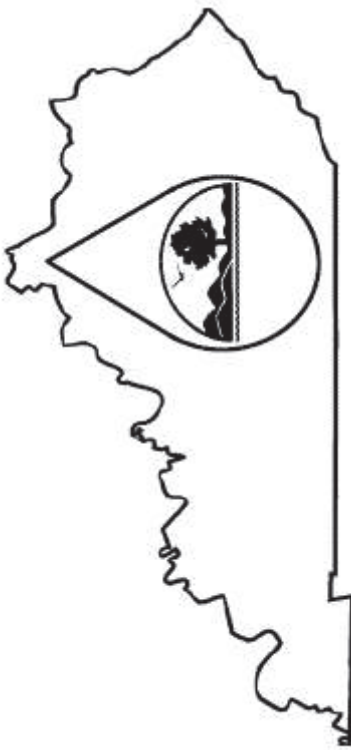

KENTUCKY POLLUTION DISCHARGE ELIMINATION SYSTEM (KPDES)

Notice of Intent (NOI) for coverage of Storm Water Discharge Associated with Construction Activities Under the KPDES Storm Water General Permit KYR100000

[Click here for Instructions \(Controls/KPDES_FormKYR10_Instructions.htm\)](#)

Click here to obtain information and a copy of the KPDES General Permit. (<http://dep.ky.gov/formslibrary/Documents/KYR10PermitPage.pdf>)

(*) indicates a required field; (✓) indicates a field may be required based on user input or is an optionally required field

Reason for Submittal: (*)	Agency Interest ID:	Permit Number: (✓)
Application for New Permit Cov ▼	Agency Interest ID	KPDES Permit Number
If change to existing permit coverage is requested, describe the changes for which modification of coverage is being sought: (✓)		
ELIGIBILITY: Stormwater discharges associated with construction activities disturbing individually one (1) acre or more, including, in the case of a common plan of development, contiguous construction activities that cumulatively equal one (1) acre or more of disturbance.		
EXCLUSIONS: The following are excluded from coverage under this general permit: 1) Are conducted at or on properties that have obtained an individual KPDES permit for the discharge of other wastewaters which requires the development and implementation of a Best Management Practices (BMP) plan; 2) Any operation that the DOW determines an individual permit would better address the discharges from that operation; 3) Any project that discharges to an Impaired Water listed in the most recent Integrated Report, §305(b) as impaired for sediment and for which an approved TMDL has been developed.		

SECTION I -- FACILITY OPERATOR INFORMATION (PERMITTEE)

Company Name:(✓) Kentucky Transportation Cabinet - District 1:		First Name:(✓) Chris	M.I.: J	Last Name:(✓) Jones
Mailing Address:(*) 603 Railroad Ave.	City:(*) Manchester	State:(*) Kentucky	Zip:(*) 40962	
eMail Address:(*) chrisj.jones@ky.gov	Business Phone:(*) 606-598-2145	Alternate Phone: Phone		

SECTION II -- GENERAL SITE LOCATION INFORMATION

Project Name:(*) 11-0185 US-25E Widening		Status of Owner/Operator(*) State Government	SIC Code(*) 1611 Highway and St
Company Name:(✓) Kentucky Transportation Cabinet - District 1:	First Name:(✓) Chris	M.I.: J	Last Name:(✓) Jones
Site Physical Address:(*) US25E Mile Point 0.40 - 2.00			
City:(*) Corbin	State:(*) Kentucky	Zip:(*) 40701	

County:(*) Laurel	Latitude(decimal degrees)(*)DMS to DD Converter (https://www.fcc.gov/media/radio/dms-decimal) 36.974333	Longitude(decimal degrees)(*) -84.100603
-----------------------------	--	--

SECTION III -- SPECIFIC SITE ACTIVITY INFORMATION

Section III requires part A or part B to be completed.

Project Description:(*) US25E Widening and access improvements
--

a. For single projects provide the following information

Total Number of Acres in Project:(✓) <div style="border: 1px solid black; padding: 2px; text-align: center;">44.5</div>	Total Number of Acres Disturbed:(✓) <div style="border: 1px solid black; padding: 2px; text-align: center;">21.0</div>
Anticipated Start Date:(✓) <div style="border: 1px solid black; padding: 2px; text-align: center;">8/22/2022</div>	Anticipated Completion Date:(✓) <div style="border: 1px solid black; padding: 2px; text-align: center;">8/22/2024</div>
b. For common plans of development provide the following information	
Total Number of Acres in Project:(✓) # Acre(s)	Total Number of Acres Disturbed:(✓) # Acre(s)
Number of individual lots in development, if applicable:(✓) # lot(s)	Number of lots in development:(✓) # lot(s)
Total acreage of lots intended to be developed:(✓) Project Acres	Number of acres intended to be disturbed at any one time:(✓) Disturbed Acres
Anticipated Start Date:(✓)	Anticipated Completion Date:(✓)
List Building Contractor(s) at the time of Application:(*) <div style="border: 1px solid black; padding: 2px;">Company Name</div>	

SECTION IV -- IF THE PERMITTED SITE DISCHARGES TO A WATER BODY THE FOLLOWING INFORMATION IS REQUIRED

Complete the following table if the permitted site discharges to a water body. Please note that if you enter a row in the below table, all columns are required to be filled out.

Unnamed Tributary?: Does discharge enter an unnamed tributary prior to entering a named receiving water?
 Latitude in decimal degrees: Format must be between 36.490000 and 39.150000, with a minimum of 5 decimal points of accuracy.
 Longitude in decimal degrees: Format must be between -89.580000 and -81.960000, with a minimum of 5 decimal points of accuracy.
 Receiving Water Name: Receiving water name must be from the following list of possible receiving waters. (click here for a list (Controls/ReceivingStream.htm)). If the discharge flows into an unnamed tributary, please enter the first "named" receiving water for which the unnamed tributary(ies) eventually flows into.

Discharge Point(s):			
Unnamed Tributary?	Latitude	Longitude	Receiving Water Name
Yes	36.96720	-84.08580	Lynn Camp Creek
Yes	36.96920	-84.08810	Horse Creek

No	36.97310	-84.09360	Horse Creek
Yes	36.97170	-84.09360	Horse Creek
No	36.97310	-84.09361	Horse Creek
No	36.97280	-84.09390	Horse Creek
No	36.97250	-84.09420	Horse Creek
No	36.97190	-84.09440	Horse Creek
No	36.97170	-84.09530	Horse Creek
Yes	36.97250	-84.09610	Horse Creek
Yes	36.97330	-84.09830	Horse Creek
Yes	36.97440	-84.10360	Horse Creek
Yes	36.97640	-84.10970	Lynn Camp Creek
Yes	36.97640	-84.11030	Lynn Camp Creek
Yes	36.97670	-84.11190	Lynn Camp Creek
Yes	36.97690	-84.11250	Lynn Camp Creek
Yes	36.97220	-84.11390	Laurel River

SECTION V -- IF THE PERMITTED SITE DISCHARGES TO A MS4 THE FOLLOWING INFORMATION IS REQUIRED 

List all MS4 Discharge Points
Latitude in decimal degrees. Format must be between 36.490000 and 39.150000, with a minimum of 5 decimal points of accuracy.
Longitude in decimal degrees. Format must be between -89.580000 and -81.960000, with a minimum of 5 decimal points of accuracy.

Name of MS4:

Date of application/notification to the MS4 for construction site permit coverage:

Date

Discharge Point(s):(*)

Latitude

Longitude



SECTION VI -- WILL THE PROJECT REQUIRE CONSTRUCTION ACTIVITIES IN A WATER BODY OR THE RIPARIAN ZONE?

Will the project require construction activities in a water body or the riparian zone?:(*)	Yes
If Yes, describe scope of activity: (✓)	Culvert and box culvert extensions.
Is a Clean Water Act 404 permit required?:(*)	Yes
Is a Clean Water Act 401 Water Quality Certification required?:(*)	Yes

SECTION VII -- NOI PREPARER INFORMATION

First Name:(*)	Joshua	M.I.:	J	Last Name:(*)	Higgins	Company Name:(*)	Kentucky Transportation Cabinet - District 1:	
Mailing Address:(*)	603 Railroad Ave.		City:(*)	Manchester	State:(*)	Kentucky	Zip:(*)	40962
eMail Address:(*)	joshuaj.higgins@ky.gov		Business Phone:(*)	606-598-2145		Alternate Phone:	Phone	

SECTION VIII -- ATTACHMENTS

Facility Location Map:(*)	Upload file
Supplemental Information:	Upload file

SECTION IX -- CERTIFICATION

I certify under penalty of law that this document and all attachments were prepared under my direction or supervision in accordance with a system designed to assure that qualified personnel properly gather and evaluate the information submitted. Based on my inquiry of the person or persons who manage the system, or those persons directly responsible for gathering the information submitted is, to the best of my knowledge and belief, true, accurate, and complete. I am aware that there are significant penalties for submitting false information, including the possibility of fine and imprisonment for knowing violations.

Signature: (*) Chris J. Jones		Title: (*) Chief District Engineer	
First Name: (*) Chris	M.I.: J	Last Name: (*) Jones	
eMail Address: (*) chrisj.jones@ky.gov	Business Phone: (*) 606-598-2145	Alternate Phone: Phone	Signature Date: (*) 5/4/2022
Click to Save Values for Future Retrieval			
Click to Submit to EEC			

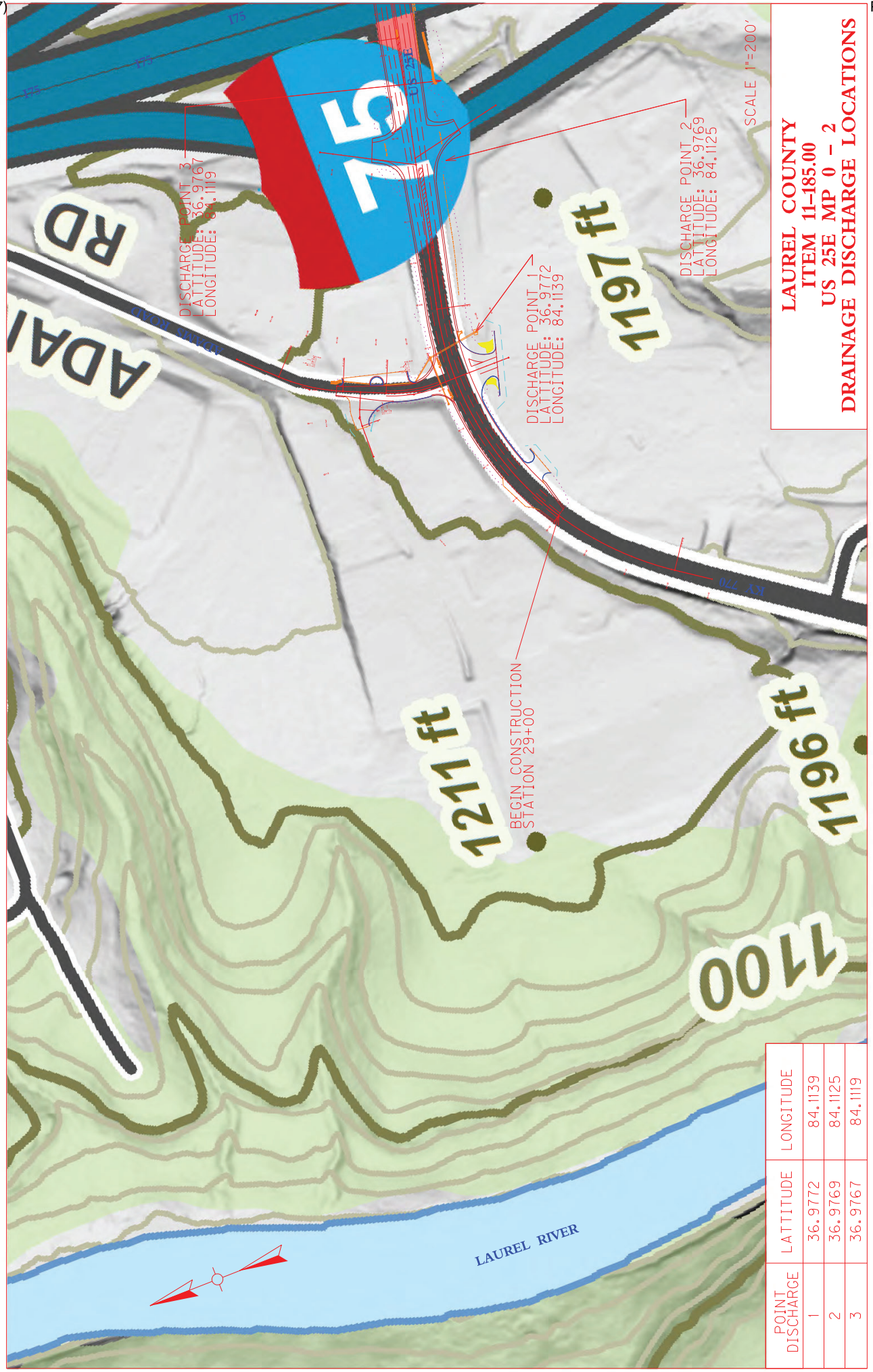

DISCHARGE POINT 3
LATITUDE: 36.9767
LONGITUDE: 84.1119

DISCHARGE POINT 1
LATITUDE: 36.9772
LONGITUDE: 84.1159

DISCHARGE POINT 2
LATITUDE: 36.9769
LONGITUDE: 84.1125

BEGIN CONSTRUCTION
STATION 29+00

SCALE 1"=200'

LAUREL COUNTY
ITEM 11-185.00
US 25E MP 0 - 2
DRAINAGE DISCHARGE LOCATIONS

POINT DISCHARGE	LATITUDE	LONGITUDE
1	36.9772	84.1139
2	36.9769	84.1125
3	36.9767	84.1119

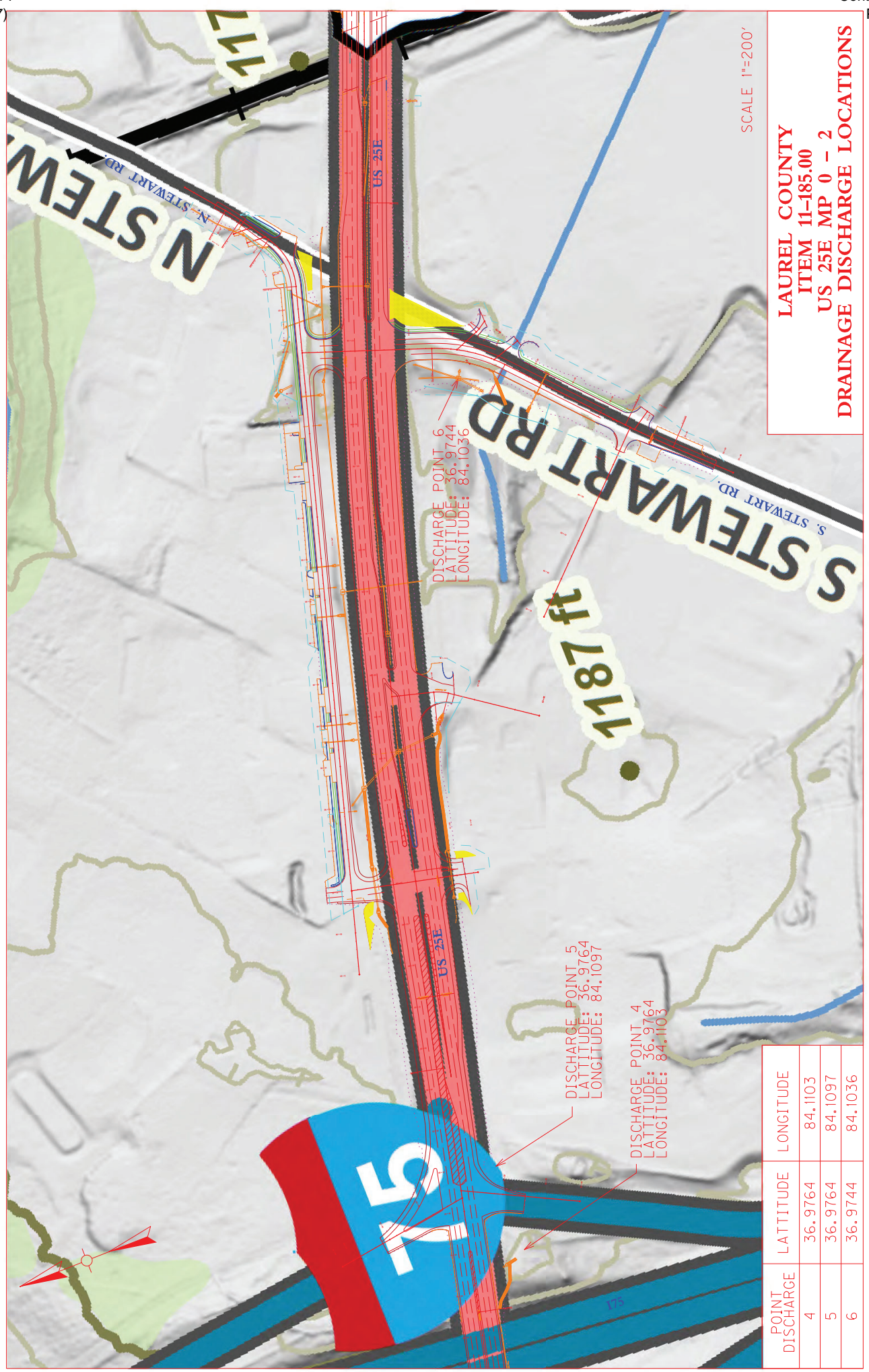

LAUREL COUNTY
ITEM 11-185.00
US 25E MP 0 - 2
DRAINAGE DISCHARGE LOCATIONS

SCALE 1"=200'

POINT DISCHARGE	LATITUDE	LONGITUDE
4	36.9764	84.1103
5	36.9764	84.1097
6	36.9744	84.1036

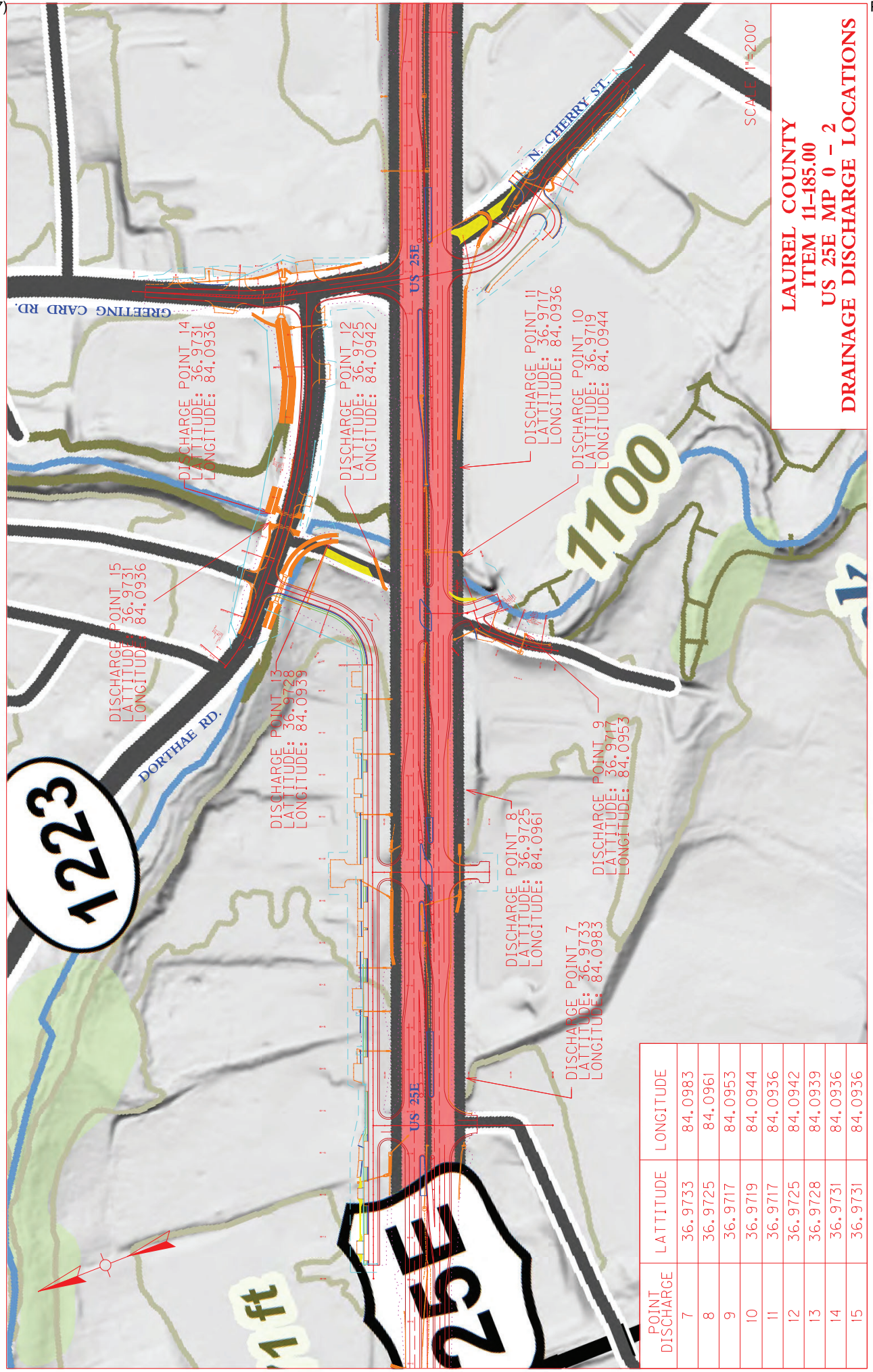

LAUREL COUNTY
ITEM 11-185.00
US 25E MP 0 - 2
DRAINAGE DISCHARGE LOCATIONS

POINT DISCHARGE	LATITUDE	LONGITUDE
7	36.9733	84.0983
8	36.9725	84.0961
9	36.9717	84.0953
10	36.9719	84.0944
11	36.9717	84.0936
12	36.9725	84.0942
13	36.9728	84.0939
14	36.9731	84.0936
15	36.9731	84.0936

DISCHARGE POINT 15
LATITUDE: 36.9731
LONGITUDE: 84.0936

DISCHARGE POINT 14
LATITUDE: 36.9731
LONGITUDE: 84.0936

DISCHARGE POINT 13
LATITUDE: 36.9728
LONGITUDE: 84.0939

DISCHARGE POINT 12
LATITUDE: 36.9725
LONGITUDE: 84.0942

DISCHARGE POINT 8
LATITUDE: 36.9725
LONGITUDE: 84.0961

DISCHARGE POINT 7
LATITUDE: 36.9733
LONGITUDE: 84.0983

DISCHARGE POINT 9
LATITUDE: 36.9717
LONGITUDE: 84.0953

DISCHARGE POINT 11
LATITUDE: 36.9717
LONGITUDE: 84.0936

DISCHARGE POINT 10
LATITUDE: 36.9719
LONGITUDE: 84.0944

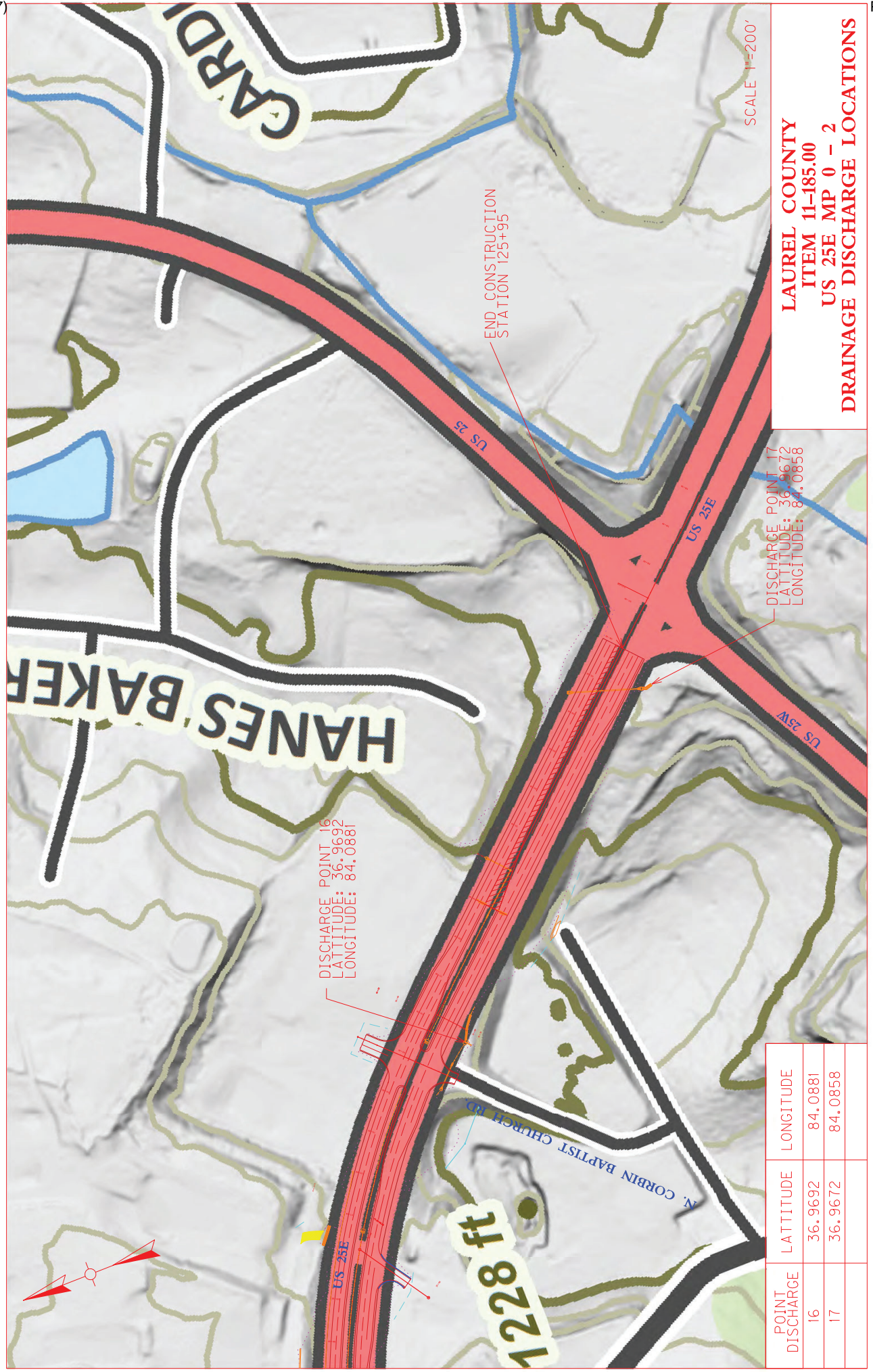

LAUREL COUNTY
ITEM 11-185.00
US 25E MP 0 - 2
DRAINAGE DISCHARGE LOCATIONS

POINT DISCHARGE	LATITUDE	LONGITUDE
16	36.9692	84.0881
17	36.9672	84.0858

PART II
SPECIFICATIONS AND STANDARD DRAWINGS

SPECIFICATIONS REFERENCE

Any reference in the plans or proposal to previous editions of the *Standard Specifications for Road and Bridge Construction* and *Standard Drawings* are superseded by *Standard Specifications for Road and Bridge Construction, Edition of 2019* and *Standard Drawings, Edition of 2020*.

SUPPLEMENTAL SPECIFICATIONS

The contractor shall use the Supplemental Specifications that are effective at the time of letting.
The Supplemental Specifications can be found at the following link:

<http://transportation.ky.gov/Construction/Pages/Kentucky-Standard-Specifications.aspx>

SPECIAL NOTE FOR PORTABLE CHANGEABLE MESSAGE SIGNS

This Special Note will apply when indicated on the plans or in the proposal.

1.0 DESCRIPTION. Furnish, install, operate, and maintain variable message signs at the locations shown on the plans or designated by the Engineer. Remove and retain possession of variable message signs when they are no longer needed on the project.

2.0 MATERIALS.

2.1 General. Use LED Variable Message Signs Class I, II, or III, as appropriate, from the Department's List of Approved Materials.

Unclassified signs may be submitted for approval by the Engineer. The Engineer may require a daytime and nighttime demonstration. The Engineer will make a final decision within 30 days after all required information is received.

2.2 Sign and Controls. All signs must:

- 1) Provide 3-line messages with each line being 8 characters long and at least 18 inches tall. Each character comprises 35 pixels.
- 2) Provide at least 40 preprogrammed messages available for use at any time. Provide for quick and easy change of the displayed message; editing of the message; and additions of new messages.
- 3) Provide a controller consisting of:
 - a) Keyboard or keypad.
 - b) Readout that mimics the actual sign display. (When LCD or LCD type readout is used, include backlighting and heating or otherwise arrange for viewing in cold temperatures.)
 - c) Non-volatile memory or suitable memory with battery backup for storing pre-programmed messages.
 - d) Logic circuitry to control the sequence of messages and flash rate.
- 4) Provide a serial interface that is capable of supporting complete remote control ability through land line and cellular telephone operation. Include communication software capable of immediately updating the message, providing complete sign status, and allowing message library queries and updates.
- 5) Allow a single person easily to raise the sign to a satisfactory height above the pavement during use, and lower the sign during travel.
- 6) Be Highway Orange on all exterior surfaces of the trailer, supports, and controller cabinet.
- 7) Provide operation in ambient temperatures from -30 to + 120 degrees Fahrenheit during snow, rain and other inclement weather.
- 8) Provide the driver board as part of a module. All modules are interchangeable, and have plug and socket arrangements for disconnection and reconnection. Printed circuit boards associated with driver boards have a conformable coating to protect against moisture.
- 9) Provide a sign case sealed against rain, snow, dust, insects, etc. The lens is UV stabilized clear plastic (polycarbonate, acrylic, or other approved material) angled to prevent glare.
- 10) Provide a flat black UV protected coating on the sign hardware, character PCB, and appropriate lens areas.
- 11) Provide a photocell control to provide automatic dimming.

- 12) Allow an on-off flashing sequence at an adjustable rate.
- 13) Provide a sight to aim the message.
- 14) Provide a LED display color of approximately 590 nm amber.
- 15) Provide a controller that is password protected.
- 16) Provide a security device that prevents unauthorized individuals from accessing the controller.
- 17) Provide the following 3-line messages preprogrammed and available for use when the sign unit begins operation:

/KEEP/RIGHT/=>=>=>/	/MIN/SPEED/**MPH/
/KEEP/LEFT/<=<=</	/ICY/BRIDGE/AHEAD/ /ONE
/LOOSE/GRAVEL/AHEAD/	LANE/BRIDGE/AHEAD/
/RD WORK/NEXT/**MILES/	/ROUGH/ROAD/AHEAD/
/TWO WAY/TRAFFIC/AHEAD/	/MERGING/TRAFFIC/AHEAD/
/PAINT/CREW/AHEAD/	/NEXT/***/MILES/
/REDUCE/SPEED/**MPH/	/HEAVY/TRAFFIC/AHEAD/
/BRIDGE/WORK/***0 FT/	/SPEED/LIMIT/**MPH/
/MAX/SPEED/**MPH/	/BUMP/AHEAD/
/SURVEY/PARTY/AHEAD/	/TWO/WAY/TRAFFIC/

*Insert numerals as directed by the Engineer.
Add other messages during the project when required by the Engineer.

2.3 Power.

- 1) Design solar panels to yield 10 percent or greater additional charge than sign consumption. Provide direct wiring for operation of the sign or arrow board from an external power source to provide energy backup for 21 days without sunlight and an on-board system charger with the ability to recharge completely discharged batteries in 24 hours.

3.0 CONSTRUCTION. Furnish and operate the variable message signs as designated on the plans or by the Engineer. Ensure the bottom of the message panel is a minimum of 7 feet above the roadway in urban areas and 5 feet above in rural areas when operating. Use Class I, II, or III signs on roads with a speed limit less than 55 mph. Use Class I or II signs on roads with speed limits 55 mph or greater.

Maintain the sign in proper working order, including repair of any damage done by others, until completion of the project. When the sign becomes inoperative, immediately repair or replace the sign. Repetitive problems with the same unit will be cause for rejection and replacement.

Use only project related messages and messages directed by the Engineer, unnecessary messages lessen the impact of the sign. Ensure the message is displayed in either one or 2 phases with each phase having no more than 3 lines of text. When no message is needed, but it is necessary to know if the sign is operable, flash only a pixel.

When the sign is not needed, move it outside the clear zone or where the Engineer directs. Variable Message Signs are the property of the Contractor and shall be removed from the project when no longer needed. The Department will not assume ownership of these signs.

4.0 MEASUREMENT. The final quantity of Variable Message Sign will be

11

the actual number of individual signs acceptably furnished and operated during the project. The Department will not measure signs replaced due to damage or rejection.

5.0 PAYMENT. The Department will pay for the Variable Message Signs at the unit price each. The Department will not pay for signs replaced due to damage or rejection. Payment is full compensation for furnishing all materials, labor, equipment, and service necessary to, operate, move, repair, and maintain or replace the variable message signs. The Department will make payment for the completed and accepted quantities under the following:

<u>Code</u>	<u>Pay Item</u>	<u>Pay Unit</u>
02671	Portable Changeable Message Sign	Each

Effective June 15, 2012

SPECIAL PROVISION FOR EMBANKMENT AT BRIDGE END BENT STRUCTURES

This Special Provision will apply when indicated on the plans or in the proposal. Section references herein are to the Department's Standard Specifications for Road and Bridge Construction, Current Edition.

1.0 DESCRIPTION. Construct a soil, granular, or rock embankment with soil, granular or cohesive pile core and place structure granular backfill, as the Plans require. Construct the embankment according to the requirements of this Special Provision, the Plans, Standard Drawing RGX 100 and 105, and the Standard Specifications, Current Edition.

2.0 MATERIALS.

2.1 Granular Embankment. Conform to Subsection 805.10. When Granular Embankment materials are erodible or unstable according to Subsection 805.03.04, use the Special Construction Methods found in 3.2 of the Special Provision.

2.2 Rock Embankment. Provide durable rock from roadway excavation that consists principally of Unweathered Limestone, Durable Shale (SDI equal to or greater than 95 according to KM 64-513), or Durable Sandstone.

2.3 Pile Core. Provide a pile core in the area of the embankments where deep foundations are to be installed unless otherwise specified. The Pile Core is the zone indicated on Standard Drawings RGX 100 and 105 designated as Pile Core. Material control of the pile core area during embankment construction is always required. Proper Pile Core construction is required for installation of foundation elements such as drilled or driven piles or drilled shafts. The type of material used to construct the pile core is as directed in the plans or below. Typically, the pile core area will be constructed from the same material used to construct the surrounding embankment. Pile Core can be classified as one of three types:

A) Pile Core - Conform to Section 206 of the Standard Specifications. Provide pile core material consisting of the same material as the adjacent embankment except the material in the pile core area shall be free of boulders or particle sizes larger than 4 inches in any dimension or any other obstructions that may hinder pile driving operations. If the pile core material hinders pile driving operations, take the appropriate means necessary to reach the required pile tip elevation, at no expense to the Department.

B) Granular Pile Core. Granular pile core is required only when specified in the plans. Select a gradation of durable rock to facilitate pile driving that conforms to Subsection 805.11. If granular pile core material hinders pile driving operations, take appropriate means necessary to reach the required pile tip elevation, at no expense to the Department.

C) Cohesive Pile Core. Cohesive Pile Core is required only when specified in the plans. Conform to Section 206 of the Standard Specifications and use soil with at least 50 percent passing a No. 4 sieve having a minimum Plasticity Index (PI) of 10. In addition, keep the cohesive pile core free of boulders, larger than 4 inches in any dimension, or any other obstructions, which would interfere with drilling operations. If cohesive pile core material interferes with drilling operations, take appropriate means necessary to maintain

excavation stability, at no expense to the Department.

2.4 Structure Granular Backfill. Conform to Subsection 805.11

2.5 Geotextile Fabric. Conform to Type I or Type IV in Section 214 and 843.

3.0 CONSTRUCTION.

3.1 General. Construct roadway embankments at end bents according to Section 206 and in accordance with the Special Provision, the Plans, and Standard Drawings for the full embankment section. In some instances, granular or rock embankment will be required for embankment construction for stability purposes, but this special provision does not prevent the use of soil when appropriate. Refer to the plans for specific details regarding material requirements for embankment construction.

Place and compact the pile core and structure granular backfill according to the applicable density requirements for the project. If the embankment and pile core are dissimilar materials (i.e., a granular pile core is used with a soil embankment or a cohesive pile core is used with a granular embankment), a Geotextile Fabric, Type IV, will be required between the pile core and embankment in accordance with Sections 214 and 843 of the Standard Specifications.

When granular or rock embankment is required for embankment construction, conform to the general requirements of Subsection 206.03.02 B. In addition, place the material in no greater than 2-foot loose lifts and compact with a vibrating smooth wheel roller capable of producing a minimum centrifugal force of 15 tons. Apply these requirements to the full width of the embankment for a distance of half the embankment height or 50 feet, whichever is greater, as shown on Standard Drawing RGX-105.

When using granular pile core, install 8-inch perforated underdrain pipe at or near the elevation of the original ground in the approximate locations depicted on the standard drawing, and as the Engineer directs, to ensure positive drainage of the embankment. Wrap the perforated pipe with a fabric of a type recommended by the pipe manufacturer.

After constructing the embankment, excavate for the end bent cap, drive piling, install shafts or other foundation elements, place the mortar bed, construct the end bent, and complete the embankment to finish grade according to the construction sequence shown on the Plans or Standard Drawings and as specified hereinafter.

Certain projects may require widening of existing embankments and the removal of substructures. Construct embankment according to the plans. Substructure removal shall be completed according to the plans and Section 203. Excavation may be required at the existing embankment in order to place the structure granular backfill as shown in the Standard Drawings.

After piles are driven or shafts installed (see design drawings), slope the bottom of the excavation towards the ends of the trench as noted on the plans for drainage. Using a separate pour, place concrete mortar, or any class concrete, to provide a base for forming and placing the cap. Place side forms for the end bent after the mortar has set sufficiently to support workmen and forms without being disturbed.

Install 4-inch perforated pipe in accordance with the plans and Standard Drawings. In the event slope protection extends above the elevation of the perforated pipe, extend the pipe through the slope protection.

After placing the end bent cap and achieving required concrete cylinder strengths, remove adjacent forms and fill the excavation with compacted structure granular backfill material (maximum 1' loose lifts) to the level of the berm prior to placing beams for the bridge. Place Type IV geotextile fabric between embankment material and structure granular backfill. After completing the end bent backwall, or after completing the span end

wall, place the compacted structure granular backfill (maximum 1' loose lifts) to subgrade elevation. If the original excavation is enlarged, fill the entire volume with compacted structure granular backfill (maximum 1' loose lifts) at no expense to the Department. Do not place backfill before removing adjacent form work. Place structure granular backfill material in trench ditches at the ends of the excavation. Place Geotextile Fabric, Type IV over the surface of the compacted structure granular backfill prior to placing aggregate base course.

Tamp the backfill with hand tampers, pneumatic tampers, or other means approved by the Engineer. Thoroughly compact the backfill under the overhanging portions of the structure to ensure that the backfill is in intimate contact with the sides of the structure.

Do not apply seeding, sodding, or other vegetation to the exposed granular embankment.

3.2 Special Construction Methods. Erodible or unstable materials may erode even when protected by riprap or channel lining; use the special construction method described below when using these materials.

Use fine aggregates or friable sandstone granular embankment at "dry land" structures only. Do not use them at stream crossings or locations subject to flood waters.

For erodible or unstable materials having 50 percent or more passing the No. 4 sieve, protect with geotextile fabric. Extend the fabric from the original ground to the top of slope over the entire area of the embankment slopes on each side of, and in front of, the end bent. Cover the fabric with at least 12 inches of non-erodible material.

For erodible or unstable materials having less than 50 percent passing a No. 4 sieve, cover with at least 12 inches of non-erodible material.

Where erodible or unstable granular embankment will be protected by riprap or channel lining, place Type IV geotextile fabric between the embankment and the specified slope protection.

4.0 MEASUREMENT.

4.1 Granular Embankment. The Department will measure the quantity in cubic yards using the plan quantity, increased or decreased by authorized adjustments as specified in Section 204. The Department will not measure for payment any Granular Embankment that is not called for in the plans.

The Department will not measure for payment any special construction caused by using erodible or unstable materials and will consider it incidental to the Granular Embankment regardless of whether the erodible or unstable material was specified or permitted.

4.2 Rock Embankment. The Department will not measure for payment any rock embankment and will consider it incidental to roadway excavation or embankment in place, as applicable. Rock embankments will be constructed using granular embankment on projects where there is no available rock present within the excavation limits of the project.

4.3 Pile Core. Pile core will be measured and paid under roadway excavation or embankment in place, as applicable. The Department will not measure the pile core for separate payment. The Department will not measure for payment the 8-inch perforated underdrain pipe and will consider it incidental to the Pile Core.

4.4 Structure Granular Backfill. The Department will measure the quantity in cubic yards using the plan quantity, increased or decreased by authorized adjustments as specified in Section 204. The Department will not measure any additional material required for backfill outside the limits shown on the Plans and Standard Drawings for payment and will

consider it incidental to the work.

The Department will not measure for payment the 4-inch perforated underdrain pipe and will consider it incidental to the Structure Granular Backfill.

4.5 Geotextile Fabric. The Department will not measure the quantity of fabric used for separating dissimilar materials when constructing the embankment and pile core and will consider it incidental to embankment construction.

The Department will not measure for payment the Geotextile Fabric used to separate the Structure Granular Backfill from the embankment and aggregate base course and will consider it incidental to Structure Granular Backfill.

The Department will not measure for payment the Geotextile Fabric required for construction with erodible or unstable materials and will consider it incidental to embankment construction.

4.6 End Bent. The Department will measure the quantities according to the Contract. The Department will not measure furnishing and placing the 2-inch mortar or concrete bed for payment and will consider it incidental to the end bent construction.

4.7 Structure Excavation. The Department will not measure structure excavation on new embankments for payment and will consider it incidental to the Structure Granular Backfill or Concrete as applicable.

5.0 PAYMENT. The Department will make payment for the completed and accepted quantities under the following:

<u>Code</u>	<u>Pay Item</u>	<u>Pay Unit</u>
02223	Granular Embankment	Cubic Yards
02231	Structure Granular Backfill	Cubic Yards

The Department will consider payment as full compensation for all work required in this provision.

September 16, 2016

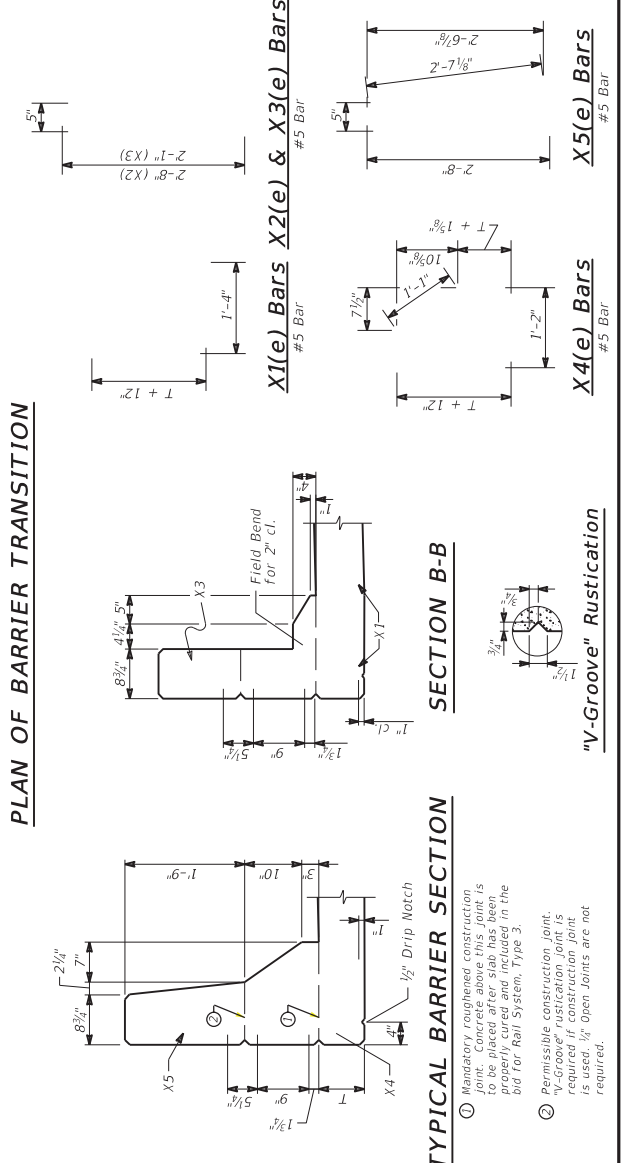
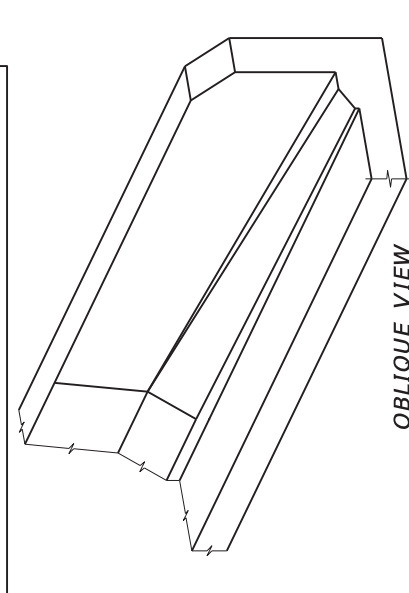
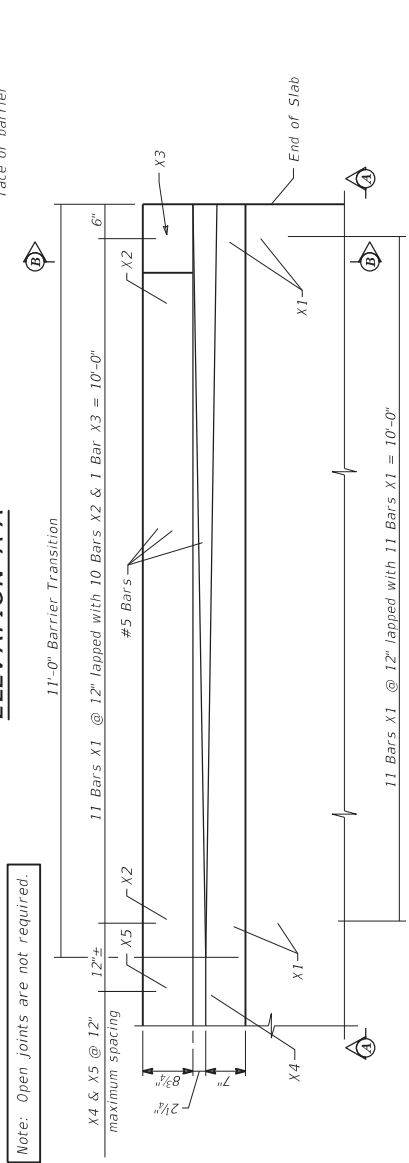
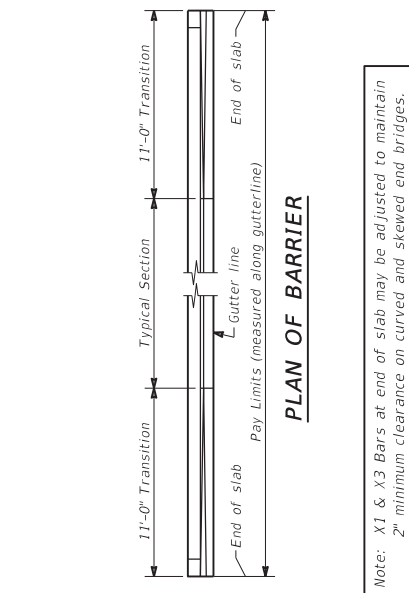
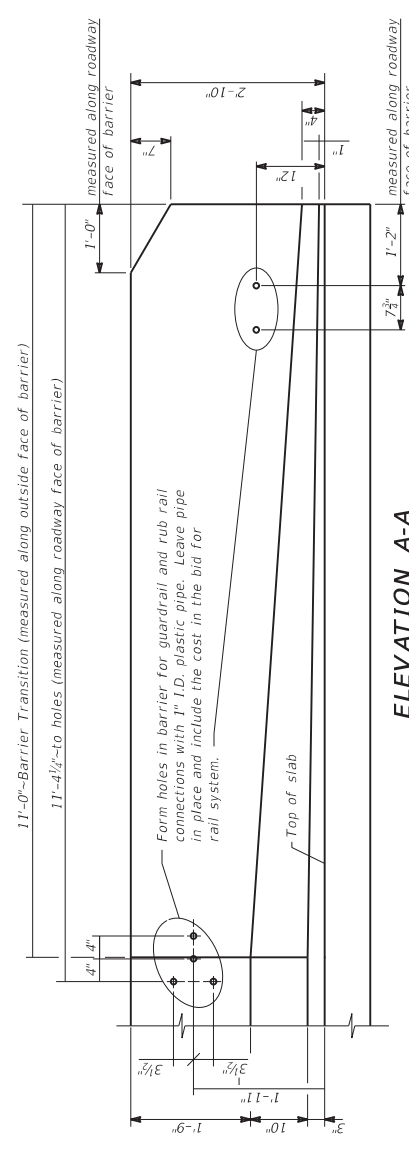

General Notes
CONCRETE: Use Class "AA" Concrete throughout.

OPTIONAL WELDED WIRE REINFORCEMENT:
At the contractor's option, deformed welded wire reinforcement (WWR) in accordance with ASTM A497 and epoxy coated in accordance with ASTM A884 may be used in place of stirrup bars X2, X3, and X5 as well as the straight or longitudinal reinforcement attached to these stirrups. Use size D31 wire for both stirrups and straight reinforcement. Locate and space the wire reinforcement the same as the conventional reinforcement except lower the top straight bar at least 2 1/2" away from the bend in the stirrup. Use a minimum 2'-8" lap for the straight reinforcement between sheets of WWR.

MEASUREMENT: The linear foot bid for the barrier is measured along the roadway gutterline. Include all reinforcement shown and all concrete above the top of slab in the bid item for Rail System Type 3.

REINFORCEMENT: All reinforcement shown on this sheet is to be epoxy coated. Use stirrup bend diameters for all bent bars. Straight reinforcement is to be Size #5 and lapped 2'-2" when necessary.

MAINTENANCE NOTES: NOT FOR NEW CONSTRUCTION. ONLY USE FOR REPAIRING OR PATCHING EXISTING CONCRETE. USE 4000 PSI CLASS "AA" CONCRETE FOR REPAIRS TO EXISTING JERSEY SHAPES.

KENTUCKY
DEPARTMENT OF HIGHWAYS

RAIL SYSTEM TYPE 3

SUBMITTED: *Bob Rubin*
DIVISION DIRECTOR

06-23-20
DATE

002

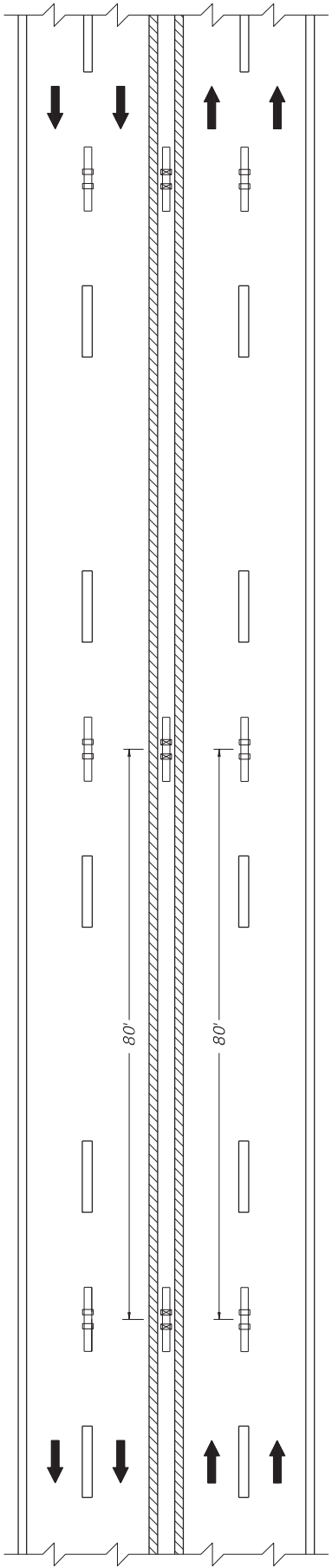

ARRANGEMENT "A" (UNDIVIDED HIGHWAY)

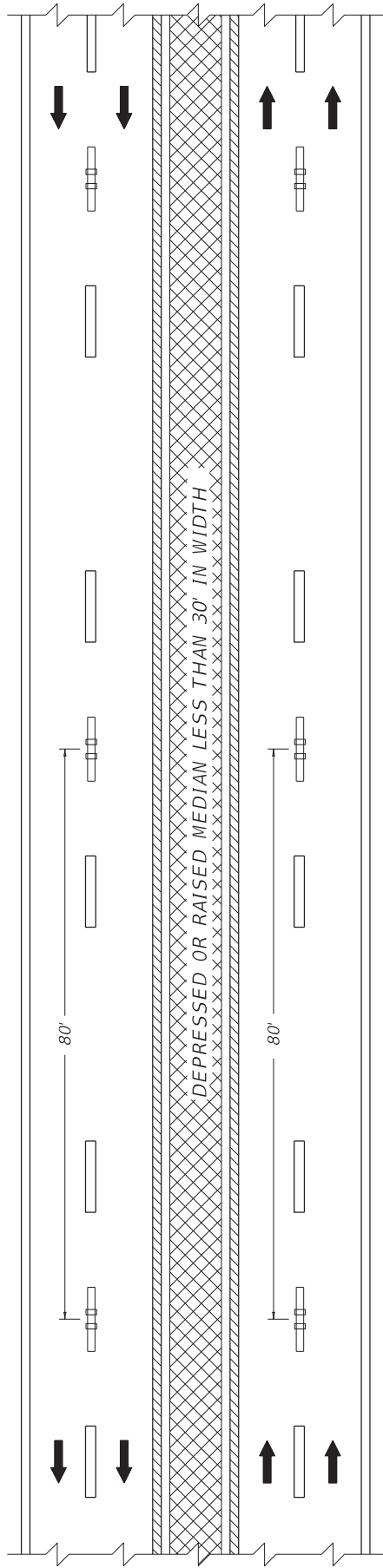

ARRANGEMENT "B" (DIVIDED HIGHWAY WITH DEPRESSED OR RAISED MEDIAN LESS THAN 30' IN WIDTH)

~ NOTES ~

1. MARKERS INSTALLED WITH DOUBLE YELLOW CENTERLINES SHOULD BE PLACED BETWEEN THE TWO LINES.
2. MARKERS INSTALLED ALONG LANE LINES SHOULD BE PLACED BETWEEN AND IN LINE WITH THE SKIPS.
3. MARKERS SHALL NOT BE INSTALLED ON TOP OF THE PAVEMENT JOINT. OFFSET MARKERS A MINIMUM OF 2" FROM THE PAVEMENT JOINT. ENSURE THAT THE FINISHED LINE OF MARKERS IS STRAIGHT WITH MINIMAL LATERAL DEVIATION. MARKERS MAY BE ELIMINATED OR PLACEMENT ADJUSTED AT THE DISCRETION OF THE ENGINEER.
4. MARKERS SHALL BE INSTALLED AT 40' SPACING ALONG SOLID WHITE AUXILIARY LANES. MARKER COLOR SHALL MATCH THE MARKERS INSTALLED ALONG THE WHITE LANE LINES.
 BID ITEMS
 06610 - INLAID PAVEMENT MARKER - MW
 06612 - INLAID PAVEMENT MARKER - BY
 UNIT TO BID
 EACH
 EACH

LEGEND

	BI-DIRECTIONAL PAVEMENT MARKER (YELLOW)
	MONO-DIRECTIONAL PAVEMENT MARKER (WHITE)
	MARKINGS (YELLOW)
	MARKINGS (WHITE)
	DEPRESSED OR RAISED MEDIAN

DRAWING NOT TO SCALE

KENTUCKY DEPARTMENT OF HIGHWAYS
INLAID PAVEMENT MARKER ARRANGEMENTS MULTI-LANE ROADWAYS

SUBMITTED _____ DATE 06-09-21
 DIVISION DIRECTOR _____
 006

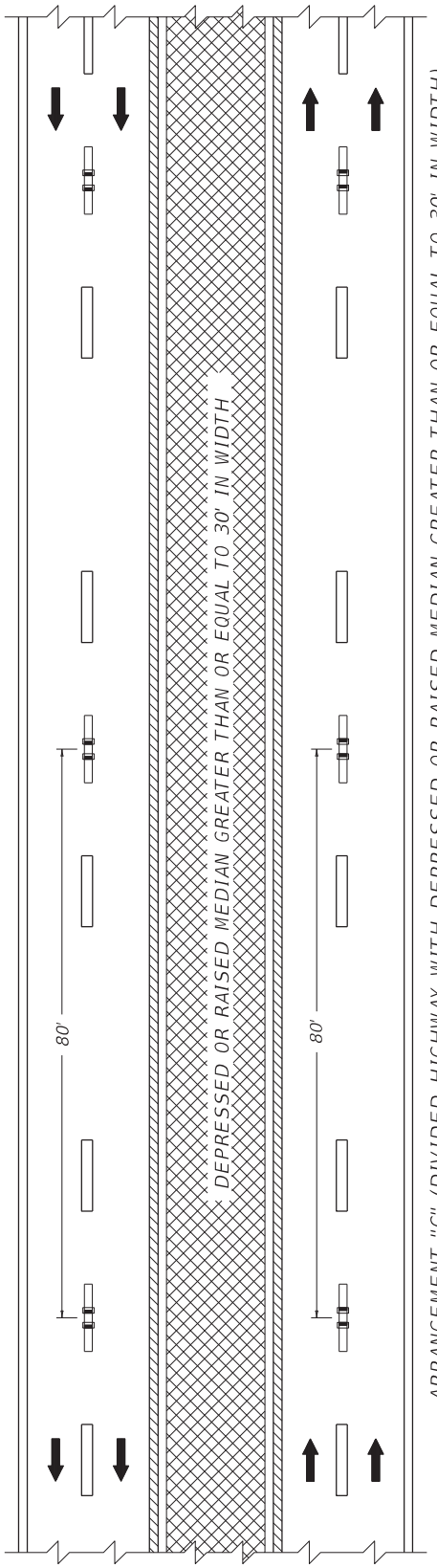

ARRANGEMENT "C" (DIVIDED HIGHWAY WITH DEPRESSED OR RAISED MEDIAN GREATER THAN OR EQUAL TO 30' IN WIDTH)

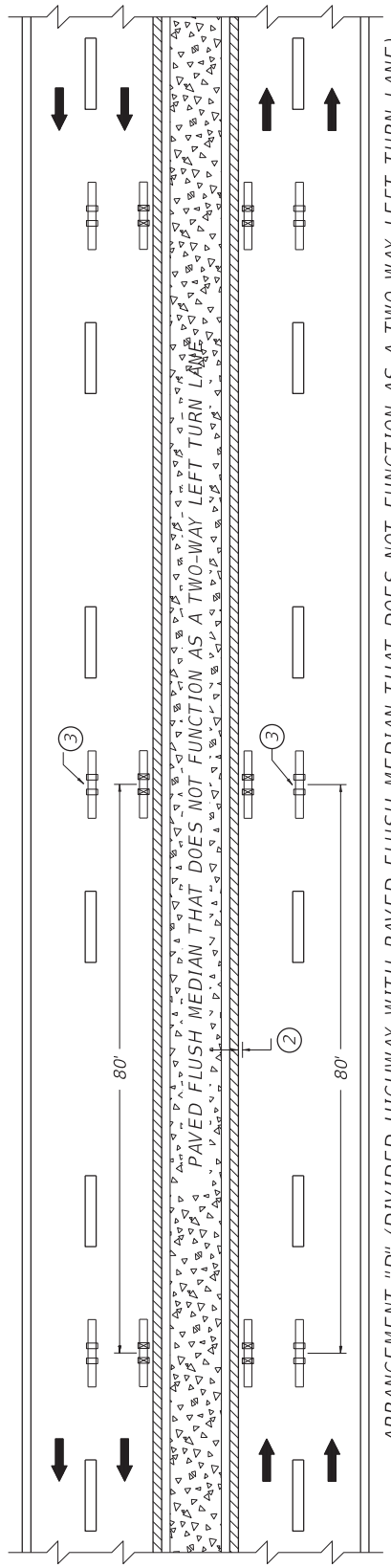

ARRANGEMENT "D" (DIVIDED HIGHWAY WITH PAVED FLUSH MEDIAN THAT DOES NOT FUNCTION AS A TWO-WAY LEFT TURN LANE)

- ~ NOTES ~
1. MARKERS INSTALLED ALONG LANE LINES SHOULD BE PLACED BETWEEN AND IN LINE WITH THE SKIPS.
 2. MARKERS INSTALLED ALONG EDGE LINES SHOULD BE PLACED SO THAT THE NEAR EDGE OF THE GROOVE IS NO MORE THAN 1" FROM THE NEAR EDGE OF THE LINE.
 3. IF WIDTH OF PAVED FLUSH MEDIAN IS GREATER THAN OR EQUAL TO 30', BI-DIRECTIONAL (WHITE-RED) MARKERS SHALL BE USED ALONG THE LANE LINES IN LIEU OF MONO-DIRECTIONAL (WHITE) MARKERS.
 4. MARKERS SHALL NOT BE INSTALLED ON TOP OF THE PAVEMENT JOINT. OFFSET MARKERS A MINIMUM OF 2" FROM THE PAVEMENT JOINT. ENSURE THAT THE FINISHED LINE OF MARKERS IS STRAIGHT WITH MINIMAL LATERAL DEVIATION. MARKERS MAY BE ELIMINATED OR PLACEMENT ADJUSTED AT THE DISCRETION OF THE ENGINEER.
 5. MARKERS SHALL BE INSTALLED AT 40' SPACING ALONG SOLID WHITE AUXILIARY LANES. MARKER COLOR SHALL MATCH THE MARKERS INSTALLED ALONG THE WHITE LANE LINES.
- BID ITEMS
 06610 - INLAID PAVEMENT MARKER - MW
 06612 - INLAID PAVEMENT MARKER - BY
 06613 - INLAID PAVEMENT MARKER - B W/R

LEGEND

	BI-DIRECTIONAL PAVEMENT MARKER (YELLOW)
	BI-DIRECTIONAL PAVEMENT MARKER (WHITE-RED)
	MONO-DIRECTIONAL PAVEMENT MARKER (WHITE)
	MARKINGS (YELLOW)
	MARKINGS (WHITE)
	FLUSH MEDIAN
	DEPRESSED OR RAISED MEDIAN

DRAWING NOT TO SCALE

KENTUCKY
DEPARTMENT OF HIGHWAYS
INLAID PAVEMENT MARKER
ARRANGEMENTS
MULTI-LANE ROADWAYS

SUBMITTED _____ 06-09-21
DIVISION DIRECTOR _____ DATE
Jim A.
007

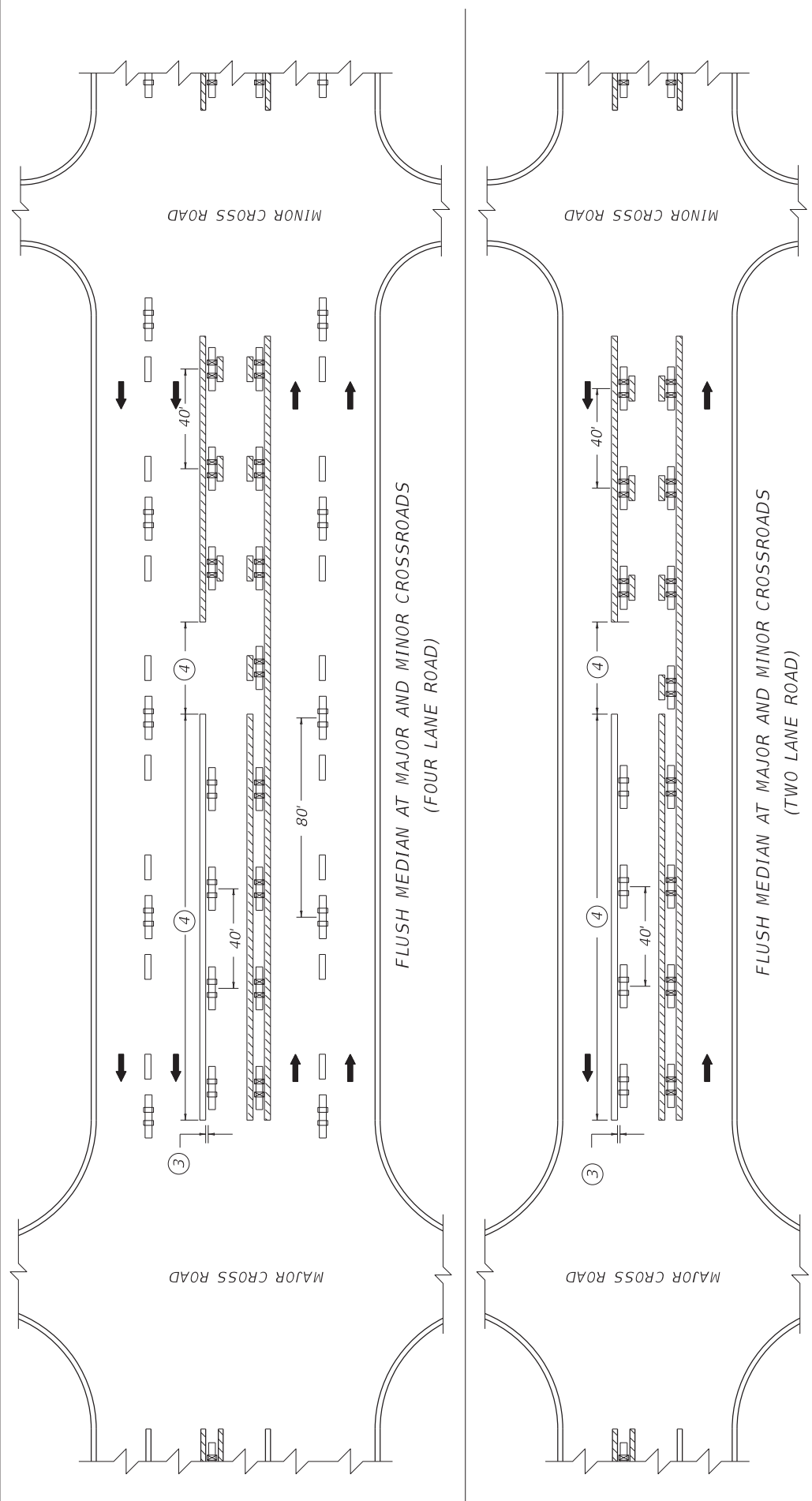

DRAWING NOT TO SCALE
USE WITH CUR. STD. DWG.
TPM-207

KENTUCKY
DEPARTMENT OF HIGHWAYS
INLAID PAVEMENT MARKER
ARRANGEMENTS
TWO-WAY, LEFT-TURN LANE

SUBMITTED: *[Signature]*
DIVISION DIRECTOR

06-09-21
DATE

015

LEGEND

	BI-DIRECTIONAL PAVEMENT MARKER (YELLOW)
	MONO-DIRECTIONAL PAVEMENT MARKER (WHITE)
	MARKINGS (YELLOW)
	MARKINGS (WHITE)

- ~ NOTES ~
1. MARKERS INSTALLED AT DOUBLE YELLOW CENTERLINES SHALL BE PLACED BETWEEN THE TWO LINES.
 2. MARKERS INSTALLED ALONG LANE LINES OR DASHED YELLOW CENTERLINES SHALL BE PLACED BETWEEN AND IN LINE WITH THE SKIPS.
 3. MARKERS INSTALLED ALONG EDGE LINES SHALL BE PLACED SO THAT THE NEAR EDGE OF THE GROOVE IS NO MORE THAN 1" FROM THE NEAR EDGE OF THE LINE.
 4. LENGTH TO BE DETERMINED ON A PROJECT BY PROJECT BASIS.
 5. MARKERS SHALL NOT BE INSTALLED ON TOP OF THE PAVEMENT JOINT. OFFSET MARKERS A MINIMUM OF 2" FROM THE PAVEMENT JOINT. ENSURE THAT THE FINISHED LINE OF MARKERS IS STRAIGHT WITH MINIMAL LATERAL DEVIATION. MARKERS MAY BE ELIMINATED OR PLACEMENT ADJUSTED AT THE DISCRETION OF THE ENGINEER.
- BID ITEMS
06610 - INLAID PAVEMENT MARKER - MW
06612 - INLAID PAVEMENT MARKER - BY
- UNIT TO BID
EACH
EACH

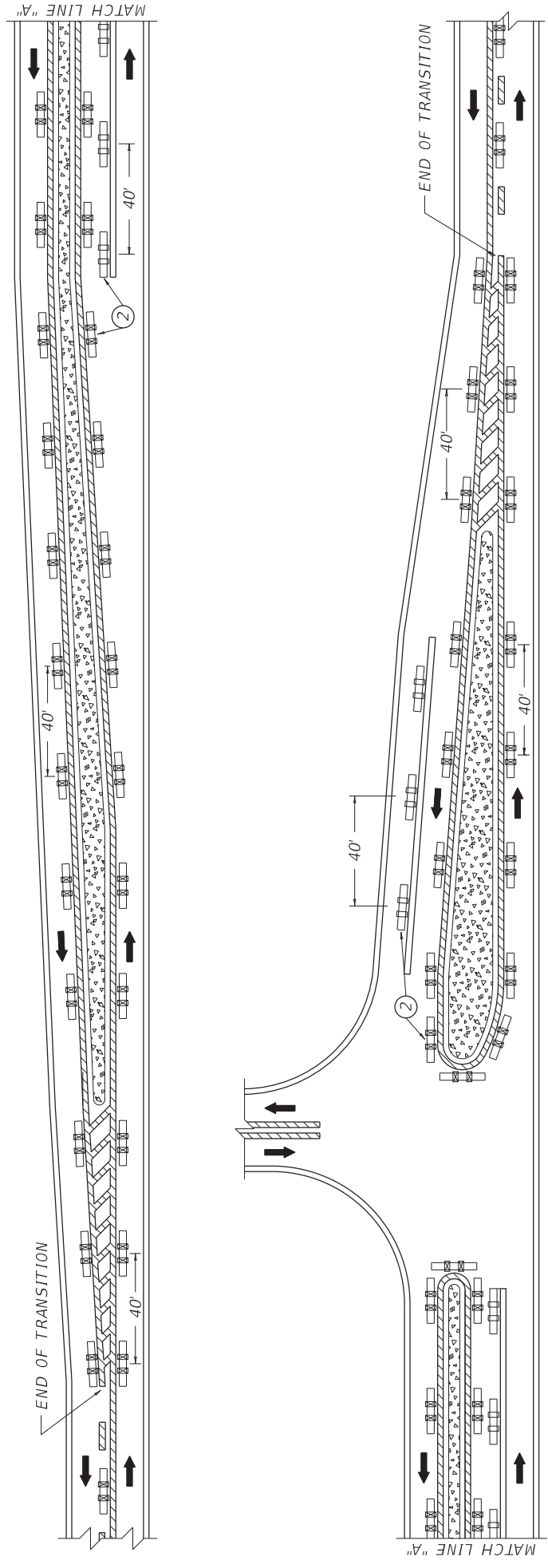

CHANNELIZED INTERSECTION ON A TWO DIRECTIONAL TWO LANE FACILITY

LEGEND

- BI-DIRECTIONAL PAVEMENT MARKER (YELLOW)
- MONO-DIRECTIONAL PAVEMENT MARKER (WHITE)
- CURBED OR FLUSH MEDIAN
- MARKINGS (YELLOW)
- MARKINGS (WHITE)

DRAWING NOT TO SCALE
USE WITH CUR. STD. DWG.
TPM-205

~ NOTES ~

1. MARKERS INSTALLED ALONG DASHED YELLOW CENTERLINES SHALL BE PLACED BETWEEN AND IN LINE WITH THE SKIPS.
- ② MARKERS INSTALLED ALONG EDGE LINES OR CHANNELIZING LINES SHALL BE PLACED SO THAT THE NEAR EDGE OF THE GROOVE IS NO MORE THAN 1" FROM THE NEAR EDGE OF THE LINE.
3. MARKERS SHALL NOT BE INSTALLED ON TOP OF THE PAVEMENT JOINT. OFFSET MARKERS A MINIMUM OF 2" FROM THE PAVEMENT JOINT. ENSURE THAT THE FINISHED LINE OF MARKERS IS STRAIGHT WITH MINIMAL LATERAL DEVIATION. MARKERS MAY BE ELIMINATED OR PLACEMENT ADJUSTED AT THE DISCRETION OF THE ENGINEER.

BID ITEMS
06610 - INLAID PAVEMENT MARKER - MW
06612 - INLAID PAVEMENT MARKER - BY
UNIT TO BID
EACH
EACH

KENTUCKY
DEPARTMENT OF HIGHWAYS
INLAID PAVEMENT MARKER
ARRANGEMENT
CHANNELIZED
INTERSECTION

SUBMITTED 06-09-21
DIVISION DIRECTOR
016

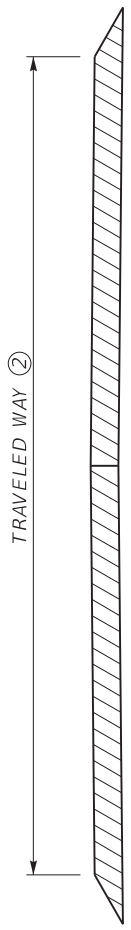

TWO LANE ROADWAY
PAVEMENT CROSS-SECTION

TRAVELED WAY	TYPE OF PAVEMENT STRIPING	NON-STATE PRIMARY ROUTES			STATE PRIMARY ROUTES	
		< 1000 ADT	>= 1000 ADT	ANY ADT	WIDTH	MATERIAL*
< 16'	④	4"	4"	6"	PAINT	THERMO (ASHPALT) TYPE I TAPE (CONCRETE)
16' TO < 20'		4"	4"	6"	PAINT	THERMO (ASHPALT) TYPE I TAPE (CONCRETE)
>=20'	③	4" ⑤	6"	6"	PAINT	THERMO (ASHPALT) TYPE I TAPE (CONCRETE)

*OTHER DURABLE NON-WATERBORNE MARKINGS MAY BE USED WITH APPROVAL FROM THE DIVISION OF TRAFFIC OPERATIONS.

~ NOTES ~

1. INSTALL PAVEMENT STRIPING ON TWO LANE, TWO WAY ROADWAYS AS DETAILED IN THE ABOVE TABLE AND IN ACCORDANCE WITH THE PAVEMENT MARKINGS AND DELINEATION CHAPTER OF THE TRAFFIC OPERATIONS GUIDANCE MANUAL. CONTACT THE DIVISION OF TRAFFIC OPERATIONS FOR ADDITIONAL GUIDANCE IF NECESSARY.
- ② THE TRAVELED WAY IS THE PORTION OF ROADWAY FOR THE MOVEMENT OF VEHICLES, EXCLUSIVE OF THE SHOULDERS.
- ③ ON TWO LANE, TWO WAY ROADWAYS THAT HAVE A TOTAL PAVEMENT WIDTH (W) THAT IS 20 FT OR GREATER, BUT LESS THAN 22 FT, EDGELINE RUMBLE STRIPS ARE NOT A STANDARD APPLICATION, BUT THEY MAY BE INSTALLED. THE DIVISION OF TRAFFIC OPERATIONS IS AVAILABLE TO ASSIST WITH THE DETERMINATION OF WHETHER OR NOT TO INSTALL EDGELINE RUMBLE STRIPS ON PAVEMENT WIDTHS LESS THAN 22 FT, AS WELL AS THE DIMENSION AND PLACEMENT DETAILS OF THE RUMBLE STRIPS AND PAVEMENT STRIPING.
- ON TWO LANE, TWO WAY ROADWAYS THAT HAVE A TOTAL PAVEMENT WIDTH (W) THAT IS 22 FT OR GREATER, BUT LESS THAN 34 FT, INSTALL PAVEMENT STRIPING AS DETAILED IN THE ABOVE TABLE AND IN CONJUNCTION WITH CENTERLINE AND EDGELINE RUMBLE STRIPS AS DETAILED ON TPR-120.
- ON TWO LANE, TWO WAY ROADWAYS THAT HAVE A TOTAL PAVEMENT WIDTH (W) THAT IS 34 FT OR GREATER, INSTALL PAVEMENT STRIPING AS DETAILED IN THE ABOVE TABLE AND IN CONJUNCTION WITH CENTERLINE AND SHOULDER RUMBLE STRIPS AS DETAILED ON TPR-125.
- ④ EDGELINES MAY BE OMITTED FROM ROADWAYS WITH A TRAVELED WAY WIDTH LESS THAN 16 FEET WITH THE APPROVAL OF THE DIVISION OF TRAFFIC OPERATIONS.
- ⑤ EDGELINES MAY BE OMITTED ON NON-STATE PRIMARY ROUTES WITH A TRAVELED WAY WIDTH GREATER THAN OR EQUAL TO 20 FEET AND AN ADT LESS THAN 1,000.
6. EDGELINES MAY BE OMITTED, BASED ON ENGINEERING JUDGMENT, IN AREAS WHERE THE PAVEMENT EDGE IS DELINEATED BY PHYSICAL OBJECTS SUCH AS CURBS, PARKING SPACES, OR OTHER MARKINGS. EDGELINES SHOULD BE INSTALLED ON ROADWAYS WITH CURB AND GUTTER IF THE POSTED SPEED LIMIT IS 45 MPH OR GREATER.

DRAWING NOT TO SCALE
USE WITH CUR. STD. DWGS.
TPR-120 & TPR-125

KENTUCKY
DEPARTMENT OF HIGHWAYS

PAVEMENT STRIPING
DETAILS FOR TWO LANE
TWO WAY ROADWAYS

SUBMITTED _____ 06-09-21
DIVISION DIRECTOR

017

PART III

EMPLOYMENT, WAGE AND RECORD REQUIREMENTS

FHWA-1273 -- Revised July 5, 2022

**REQUIRED CONTRACT PROVISIONS
FEDERAL-AID CONSTRUCTION CONTRACTS**

- I. General
- II. Nondiscrimination
- III. Non-segregated Facilities
- IV. Davis-Bacon and Related Act Provisions
- V. Contract Work Hours and Safety Standards Act Provisions
- VI. Subletting or Assigning the Contract
- VII. Safety: Accident Prevention
- VIII. False Statements Concerning Highway Projects
- IX. Implementation of Clean Air Act and Federal Water Pollution Control Act
- X. Certification Regarding Debarment, Suspension, Ineligibility and Voluntary Exclusion
- XI. Certification Regarding Use of Contract Funds for Lobbying
- XII. Use of United States-Flag Vessels:

ATTACHMENTS

A. Employment and Materials Preference for Appalachian Development Highway System or Appalachian Local Access Road Contracts (included in Appalachian contracts only)

I. GENERAL

1. Form FHWA-1273 must be physically incorporated in each construction contract funded under title 23, United States Code, as required in 23 CFR 633.102(b) (excluding emergency contracts solely intended for debris removal). The contractor (or subcontractor) must insert this form in each subcontract and further require its inclusion in all lower tier subcontracts (excluding purchase orders, rental agreements and other agreements for supplies or services). 23 CFR 633.102(e).

The applicable requirements of Form FHWA-1273 are incorporated by reference for work done under any purchase order, rental agreement or agreement for other services. The prime contractor shall be responsible for compliance by any subcontractor, lower-tier subcontractor or service provider. 23 CFR 633.102(e).

Form FHWA-1273 must be included in all Federal-aid design-build contracts, in all subcontracts and in lower tier subcontracts (excluding subcontracts for design services, purchase orders, rental agreements and other agreements for supplies or services) in accordance with 23 CFR 633.102. The design-builder shall be responsible for compliance by any subcontractor, lower-tier subcontractor or service provider.

Contracting agencies may reference Form FHWA-1273 in solicitation-for-bids or request-for-proposals documents, however, the Form FHWA-1273 must be physically incorporated (not referenced) in all contracts, subcontracts and lower-tier subcontracts (excluding purchase orders, rental agreements and other agreements for supplies or services related to a construction contract). 23 CFR 633.102(b).

2. Subject to the applicability criteria noted in the following sections, these contract provisions shall apply to all work

performed on the contract by the contractor's own organization and with the assistance of workers under the contractor's immediate superintendence and to all work performed on the contract by piecework, station work, or by subcontract. 23 CFR 633.102(d).

3. A breach of any of the stipulations contained in these Required Contract Provisions may be sufficient grounds for withholding of progress payments, withholding of final payment, termination of the contract, suspension / debarment or any other action determined to be appropriate by the contracting agency and FHWA.

4. Selection of Labor: During the performance of this contract, the contractor shall not use convict labor for any purpose within the limits of a construction project on a Federal-aid highway unless it is labor performed by convicts who are on parole, supervised release, or probation. 23 U.S.C. 114(b). The term Federal-aid highway does not include roadways functionally classified as local roads or rural minor collectors. 23 U.S.C. 101(a).

II. NONDISCRIMINATION (23 CFR 230.107(a); 23 CFR Part 230, Subpart A, Appendix A; EO 11246)

The provisions of this section related to 23 CFR Part 230, Subpart A, Appendix A are applicable to all Federal-aid construction contracts and to all related construction subcontracts of \$10,000 or more. The provisions of 23 CFR Part 230 are not applicable to material supply, engineering, or architectural service contracts.

In addition, the contractor and all subcontractors must comply with the following policies: Executive Order 11246, 41 CFR Part 60, 29 CFR Parts 1625-1627, 23 U.S.C. 140, Section 504 of the Rehabilitation Act of 1973, as amended (29 U.S.C. 794), Title VI of the Civil Rights Act of 1964, as amended (42 U.S.C. 2000d et seq.), and related regulations including 49 CFR Parts 21, 26, and 27; and 23 CFR Parts 200, 230, and 633.

The contractor and all subcontractors must comply with: the requirements of the Equal Opportunity Clause in 41 CFR 60-1.4(b) and, for all construction contracts exceeding \$10,000, the Standard Federal Equal Employment Opportunity Construction Contract Specifications in 41 CFR 60-4.3.

Note: The U.S. Department of Labor has exclusive authority to determine compliance with Executive Order 11246 and the policies of the Secretary of Labor including 41 CFR Part 60, and 29 CFR Parts 1625-1627. The contracting agency and the FHWA have the authority and the responsibility to ensure compliance with 23 U.S.C. 140, Section 504 of the Rehabilitation Act of 1973, as amended (29 U.S.C. 794), and Title VI of the Civil Rights Act of 1964, as amended (42 U.S.C. 2000d et seq.), and related regulations including 49 CFR Parts 21, 26, and 27; and 23 CFR Parts 200, 230, and 633.

The following provision is adopted from 23 CFR Part 230, Subpart A, Appendix A, with appropriate revisions to conform to the U.S. Department of Labor (US DOL) and FHWA requirements.

1. Equal Employment Opportunity: Equal Employment Opportunity (EEO) requirements not to discriminate and to take affirmative action to assure equal opportunity as set forth under laws, executive orders, rules, regulations (see 28 CFR Part 35, 29 CFR Part 1630, 29 CFR Parts 1625-1627, 41 CFR Part 60 and 49 CFR Part 27) and orders of the Secretary of Labor as modified by the provisions prescribed herein, and imposed pursuant to 23 U.S.C. 140, shall constitute the EEO and specific affirmative action standards for the contractor's project activities under this contract. The provisions of the Americans with Disabilities Act of 1990 (42 U.S.C. 12101 et seq.) set forth under 28 CFR Part 35 and 29 CFR Part 1630 are incorporated by reference in this contract. In the execution of this contract, the contractor agrees to comply with the following minimum specific requirement activities of EEO:

a. The contractor will work with the contracting agency and the Federal Government to ensure that it has made every good faith effort to provide equal opportunity with respect to all of its terms and conditions of employment and in their review of activities under the contract. 23 CFR 230.409 (g)(4) & (5).

b. The contractor will accept as its operating policy the following statement:

"It is the policy of this Company to assure that applicants are employed, and that employees are treated during employment, without regard to their race, religion, sex, sexual orientation, gender identity, color, national origin, age or disability. Such action shall include: employment, upgrading, demotion, or transfer; recruitment or recruitment advertising; layoff or termination; rates of pay or other forms of compensation; and selection for training, including apprenticeship, pre-apprenticeship, and/or on-the-job training."

2. EEO Officer: The contractor will designate and make known to the contracting officers an EEO Officer who will have the responsibility for and must be capable of effectively administering and promoting an active EEO program and who must be assigned adequate authority and responsibility to do so.

3. Dissemination of Policy: All members of the contractor's staff who are authorized to hire, supervise, promote, and discharge employees, or who recommend such action or are substantially involved in such action, will be made fully cognizant of and will implement the contractor's EEO policy and contractual responsibilities to provide EEO in each grade and classification of employment. To ensure that the above agreement will be met, the following actions will be taken as a minimum:

a. Periodic meetings of supervisory and personnel office employees will be conducted before the start of work and then not less often than once every six months, at which time the contractor's EEO policy and its implementation will be reviewed and explained. The meetings will be conducted by the EEO Officer or other knowledgeable company official.

b. All new supervisory or personnel office employees will be given a thorough indoctrination by the EEO Officer, covering all major aspects of the contractor's EEO obligations within thirty days following their reporting for duty with the contractor.

c. All personnel who are engaged in direct recruitment for the project will be instructed by the EEO Officer in the contractor's procedures for locating and hiring minorities and women.

d. Notices and posters setting forth the contractor's EEO policy will be placed in areas readily accessible to employees, applicants for employment and potential employees.

e. The contractor's EEO policy and the procedures to implement such policy will be brought to the attention of employees by means of meetings, employee handbooks, or other appropriate means.

4. Recruitment: When advertising for employees, the contractor will include in all advertisements for employees the notation: "An Equal Opportunity Employer." All such advertisements will be placed in publications having a large circulation among minorities and women in the area from which the project work force would normally be derived.

a. The contractor will, unless precluded by a valid bargaining agreement, conduct systematic and direct recruitment through public and private employee referral sources likely to yield qualified minorities and women. To meet this requirement, the contractor will identify sources of potential minority group employees and establish with such identified sources procedures whereby minority and women applicants may be referred to the contractor for employment consideration.

b. In the event the contractor has a valid bargaining agreement providing for exclusive hiring hall referrals, the contractor is expected to observe the provisions of that agreement to the extent that the system meets the contractor's compliance with EEO contract provisions. Where implementation of such an agreement has the effect of discriminating against minorities or women, or obligates the contractor to do the same, such implementation violates Federal nondiscrimination provisions.

c. The contractor will encourage its present employees to refer minorities and women as applicants for employment. Information and procedures with regard to referring such applicants will be discussed with employees.

5. Personnel Actions: Wages, working conditions, and employee benefits shall be established and administered, and personnel actions of every type, including hiring, upgrading, promotion, transfer, demotion, layoff, and termination, shall be taken without regard to race, color, religion, sex, sexual orientation, gender identity, national origin, age or disability. The following procedures shall be followed:

a. The contractor will conduct periodic inspections of project sites to ensure that working conditions and employee facilities do not indicate discriminatory treatment of project site personnel.

b. The contractor will periodically evaluate the spread of wages paid within each classification to determine any evidence of discriminatory wage practices.

c. The contractor will periodically review selected personnel actions in depth to determine whether there is evidence of discrimination. Where evidence is found, the contractor will promptly take corrective action. If the review indicates that the discrimination may extend beyond the actions reviewed, such corrective action shall include all affected persons.

d. The contractor will promptly investigate all complaints of alleged discrimination made to the contractor in connection with its obligations under this contract, will attempt to resolve such complaints, and will take appropriate corrective action

within a reasonable time. If the investigation indicates that the discrimination may affect persons other than the complainant, such corrective action shall include such other persons. Upon completion of each investigation, the contractor will inform every complainant of all of their avenues of appeal.

6. Training and Promotion:

a. The contractor will assist in locating, qualifying, and increasing the skills of minorities and women who are applicants for employment or current employees. Such efforts should be aimed at developing full journey level status employees in the type of trade or job classification involved.

b. Consistent with the contractor's work force requirements and as permissible under Federal and State regulations, the contractor shall make full use of training programs (i.e., apprenticeship and on-the-job training programs for the geographical area of contract performance). In the event a special provision for training is provided under this contract, this subparagraph will be superseded as indicated in the special provision. The contracting agency may reserve training positions for persons who receive welfare assistance in accordance with 23 U.S.C. 140(a).

c. The contractor will advise employees and applicants for employment of available training programs and entrance requirements for each.

d. The contractor will periodically review the training and promotion potential of employees who are minorities and women and will encourage eligible employees to apply for such training and promotion.

7. Unions: If the contractor relies in whole or in part upon unions as a source of employees, the contractor will use good faith efforts to obtain the cooperation of such unions to increase opportunities for minorities and women. 23 CFR 230.409. Actions by the contractor, either directly or through a contractor's association acting as agent, will include the procedures set forth below:

a. The contractor will use good faith efforts to develop, in cooperation with the unions, joint training programs aimed toward qualifying more minorities and women for membership in the unions and increasing the skills of minorities and women so that they may qualify for higher paying employment.

b. The contractor will use good faith efforts to incorporate an EEO clause into each union agreement to the end that such union will be contractually bound to refer applicants without regard to their race, color, religion, sex, sexual orientation, gender identity, national origin, age, or disability.

c. The contractor is to obtain information as to the referral practices and policies of the labor union except that to the extent such information is within the exclusive possession of the labor union and such labor union refuses to furnish such information to the contractor, the contractor shall so certify to the contracting agency and shall set forth what efforts have been made to obtain such information.

d. In the event the union is unable to provide the contractor with a reasonable flow of referrals within the time limit set forth in the collective bargaining agreement, the contractor will, through independent recruitment efforts, fill the employment vacancies without regard to race, color, religion, sex, sexual orientation, gender identity, national origin, age, or disability; making full efforts to obtain qualified and/or qualifiable minorities and women. The failure of a union to provide

sufficient referrals (even though it is obligated to provide exclusive referrals under the terms of a collective bargaining agreement) does not relieve the contractor from the requirements of this paragraph. In the event the union referral practice prevents the contractor from meeting the obligations pursuant to Executive Order 11246, as amended, and these special provisions, such contractor shall immediately notify the contracting agency.

8. Reasonable Accommodation for Applicants / Employees with Disabilities: The contractor must be familiar with the requirements for and comply with the Americans with Disabilities Act and all rules and regulations established thereunder. Employers must provide reasonable accommodation in all employment activities unless to do so would cause an undue hardship.

9. Selection of Subcontractors, Procurement of Materials and Leasing of Equipment: The contractor shall not discriminate on the grounds of race, color, religion, sex, sexual orientation, gender identity, national origin, age, or disability in the selection and retention of subcontractors, including procurement of materials and leases of equipment. The contractor shall take all necessary and reasonable steps to ensure nondiscrimination in the administration of this contract.

a. The contractor shall notify all potential subcontractors, suppliers, and lessors of their EEO obligations under this contract.

b. The contractor will use good faith efforts to ensure subcontractor compliance with their EEO obligations.

10. Assurances Required:

a. The requirements of 49 CFR Part 26 and the State DOT's FHWA-approved Disadvantaged Business Enterprise (DBE) program are incorporated by reference.

b. The contractor, subrecipient or subcontractor shall not discriminate on the basis of race, color, national origin, or sex in the performance of this contract. The contractor shall carry out applicable requirements of 49 CFR part 26 in the award and administration of DOT-assisted contracts. Failure by the contractor to carry out these requirements is a material breach of this contract, which may result in the termination of this contract or such other remedy as the recipient deems appropriate, which may include, but is not limited to:

- (1) Withholding monthly progress payments;
- (2) Assessing sanctions;
- (3) Liquidated damages; and/or
- (4) Disqualifying the contractor from future bidding as non-responsible.

c. The Title VI and nondiscrimination provisions of U.S. DOT Order 1050.2A at Appendixes A and E are incorporated by reference. 49 CFR Part 21.

11. Records and Reports: The contractor shall keep such records as necessary to document compliance with the EEO requirements. Such records shall be retained for a period of three years following the date of the final payment to the contractor for all contract work and shall be available at reasonable times and places for inspection by authorized representatives of the contracting agency and the FHWA.

a. The records kept by the contractor shall document the following:

(1) The number and work hours of minority and non-minority group members and women employed in each work classification on the project;

(2) The progress and efforts being made in cooperation with unions, when applicable, to increase employment opportunities for minorities and women; and

(3) The progress and efforts being made in locating, hiring, training, qualifying, and upgrading minorities and women.

b. The contractors and subcontractors will submit an annual report to the contracting agency each July for the duration of the project indicating the number of minority, women, and non-minority group employees currently engaged in each work classification required by the contract work. This information is to be reported on [Form FHWA-1391](#). The staffing data should represent the project work force on board in all or any part of the last payroll period preceding the end of July. If on-the-job training is being required by special provision, the contractor will be required to collect and report training data. The employment data should reflect the work force on board during all or any part of the last payroll period preceding the end of July.

III. NONSEGREGATED FACILITIES

This provision is applicable to all Federal-aid construction contracts and to all related construction subcontracts of more than \$10,000. 41 CFR 60-1.5.

As prescribed by 41 CFR 60-1.8, the contractor must ensure that facilities provided for employees are provided in such a manner that segregation on the basis of race, color, religion, sex, sexual orientation, gender identity, or national origin cannot result. The contractor may neither require such segregated use by written or oral policies nor tolerate such use by employee custom. The contractor's obligation extends further to ensure that its employees are not assigned to perform their services at any location under the contractor's control where the facilities are segregated. The term "facilities" includes waiting rooms, work areas, restaurants and other eating areas, time clocks, restrooms, washrooms, locker rooms and other storage or dressing areas, parking lots, drinking fountains, recreation or entertainment areas, transportation, and housing provided for employees. The contractor shall provide separate or single-user restrooms and necessary dressing or sleeping areas to assure privacy between sexes.

IV. DAVIS-BACON AND RELATED ACT PROVISIONS

This section is applicable to all Federal-aid construction projects exceeding \$2,000 and to all related subcontracts and lower-tier subcontracts (regardless of subcontract size), in accordance with 29 CFR 5.5. The requirements apply to all projects located within the right-of-way of a roadway that is functionally classified as Federal-aid highway. 23 U.S.C. 113. This excludes roadways functionally classified as local roads or rural minor collectors, which are exempt. 23 U.S.C. 101. Where applicable law requires that projects be treated as a project on a Federal-aid highway, the provisions of this subpart will apply regardless of the location of the project. Examples include: Surface Transportation Block Grant Program projects funded under 23 U.S.C. 133 [excluding recreational trails projects], the Nationally Significant Freight and Highway

Projects funded under 23 U.S.C. 117, and National Highway Freight Program projects funded under 23 U.S.C. 167.

The following provisions are from the U.S. Department of Labor regulations in 29 CFR 5.5 "Contract provisions and related matters" with minor revisions to conform to the FHWA-1273 format and FHWA program requirements.

1. Minimum wages (29 CFR 5.5)

a. All laborers and mechanics employed or working upon the site of the work, will be paid unconditionally and not less often than once a week, and without subsequent deduction or rebate on any account (except such payroll deductions as are permitted by regulations issued by the Secretary of Labor under the Copeland Act (29 CFR part 3)), the full amount of wages and bona fide fringe benefits (or cash equivalents thereof) due at time of payment computed at rates not less than those contained in the wage determination of the Secretary of Labor which is attached hereto and made a part hereof, regardless of any contractual relationship which may be alleged to exist between the contractor and such laborers and mechanics.

Contributions made or costs reasonably anticipated for bona fide fringe benefits under section 1(b)(2) of the Davis-Bacon Act on behalf of laborers or mechanics are considered wages paid to such laborers or mechanics, subject to the provisions of paragraph 1.d. of this section; also, regular contributions made or costs incurred for more than a weekly period (but not less often than quarterly) under plans, funds, or programs which cover the particular weekly period, are deemed to be constructively made or incurred during such weekly period. Such laborers and mechanics shall be paid the appropriate wage rate and fringe benefits on the wage determination for the classification of work actually performed, without regard to skill, except as provided in 29 CFR 5.5(a)(4). Laborers or mechanics performing work in more than one classification may be compensated at the rate specified for each classification for the time actually worked therein: Provided, That the employer's payroll records accurately set forth the time spent in each classification in which work is performed. The wage determination (including any additional classification and wage rates conformed under paragraph 1.b. of this section) and the Davis-Bacon poster (WH-1321) shall be posted at all times by the contractor and its subcontractors at the site of the work in a prominent and accessible place where it can be easily seen by the workers.

b.(1) The contracting officer shall require that any class of laborers or mechanics, including helpers, which is not listed in the wage determination and which is to be employed under the contract shall be classified in conformance with the wage determination. The contracting officer shall approve an additional classification and wage rate and fringe benefits therefore only when the following criteria have been met:

(i) The work to be performed by the classification requested is not performed by a classification in the wage determination; and

(ii) The classification is utilized in the area by the construction industry; and

(iii) The proposed wage rate, including any bona fide fringe benefits, bears a reasonable relationship to the wage rates contained in the wage determination.

(2) If the contractor and the laborers and mechanics to be employed in the classification (if known), or their representatives, and the contracting officer agree on the classification and wage rate (including the amount designated for fringe benefits where appropriate), a report of the action taken shall be sent by the contracting officer to the Administrator of the Wage and Hour Division, U.S. Department of Labor, Washington, DC 20210. The Administrator, or an authorized representative, will approve, modify, or disapprove every additional classification action within 30 days of receipt and so advise the contracting officer or will notify the contracting officer within the 30-day period that additional time is necessary.

(3) In the event the contractor, the laborers or mechanics to be employed in the classification or their representatives, and the contracting officer do not agree on the proposed classification and wage rate (including the amount designated for fringe benefits, where appropriate), the contracting officer shall refer the questions, including the views of all interested parties and the recommendation of the contracting officer, to the Administrator for determination. The Administrator, or an authorized representative, will issue a determination within 30 days of receipt and so advise the contracting officer or will notify the contracting officer within the 30-day period that additional time is necessary.

(4) The wage rate (including fringe benefits where appropriate) determined pursuant to paragraphs 1.b.(2) or 1.b.(3) of this section, shall be paid to all workers performing work in the classification under this contract from the first day on which work is performed in the classification.

c. Whenever the minimum wage rate prescribed in the contract for a class of laborers or mechanics includes a fringe benefit which is not expressed as an hourly rate, the contractor shall either pay the benefit as stated in the wage determination or shall pay another bona fide fringe benefit or an hourly cash equivalent thereof.

d. If the contractor does not make payments to a trustee or other third person, the contractor may consider as part of the wages of any laborer or mechanic the amount of any costs reasonably anticipated in providing bona fide fringe benefits under a plan or program, Provided, That the Secretary of Labor has found, upon the written request of the contractor, that the applicable standards of the Davis-Bacon Act have been met. The Secretary of Labor may require the contractor to set aside in a separate account assets for the meeting of obligations under the plan or program.

2. Withholding (29 CFR 5.5)

The contracting agency shall upon its own action or upon written request of an authorized representative of the Department of Labor, withhold or cause to be withheld from the contractor under this contract, or any other Federal contract with the same prime contractor, or any other federally-assisted contract subject to Davis-Bacon prevailing wage requirements, which is held by the same prime contractor, so much of the accrued payments or advances as may be considered necessary to pay laborers and mechanics,

including apprentices, trainees, and helpers, employed by the contractor or any subcontractor the full amount of wages required by the contract. In the event of failure to pay any laborer or mechanic, including any apprentice, trainee, or helper, employed or working on the site of the work, all or part of the wages required by the contract, the contracting agency may, after written notice to the contractor, take such action as may be necessary to cause the suspension of any further payment, advance, or guarantee of funds until such violations have ceased.

3. Payrolls and basic records (29 CFR 5.5)

a. Payrolls and basic records relating thereto shall be maintained by the contractor during the course of the work and preserved for a period of three years thereafter for all laborers and mechanics working at the site of the work. Such records shall contain the name, address, and social security number of each such worker, his or her correct classification, hourly rates of wages paid (including rates of contributions or costs anticipated for bona fide fringe benefits or cash equivalents thereof of the types described in section 1(b)(2)(B) of the Davis-Bacon Act), daily and weekly number of hours worked, deductions made and actual wages paid. Whenever the Secretary of Labor has found under 29 CFR 5.5(a)(1)(iv) that the wages of any laborer or mechanic include the amount of any costs reasonably anticipated in providing benefits under a plan or program described in section 1(b)(2)(B) of the Davis-Bacon Act, the contractor shall maintain records which show that the commitment to provide such benefits is enforceable, that the plan or program is financially responsible, and that the plan or program has been communicated in writing to the laborers or mechanics affected, and records which show the costs anticipated or the actual cost incurred in providing such benefits. Contractors employing apprentices or trainees under approved programs shall maintain written evidence of the registration of apprenticeship programs and certification of trainee programs, the registration of the apprentices and trainees, and the ratios and wage rates prescribed in the applicable programs.

b.(1) The contractor shall submit weekly for each week in which any contract work is performed a copy of all payrolls to the contracting agency. The payrolls submitted shall set out accurately and completely all of the information required to be maintained under 29 CFR 5.5(a)(3)(i), except that full social security numbers and home addresses shall not be included on weekly transmittals. Instead the payrolls shall only need to include an individually identifying number for each employee (e.g., the last four digits of the employee's social security number). The required weekly payroll information may be submitted in any form desired. Optional Form WH-347 is available for this purpose from the Wage and Hour Division Web site. The prime contractor is responsible for the submission of copies of payrolls by all subcontractors. Contractors and subcontractors shall maintain the full social security number and current address of each covered worker, and shall provide them upon request to the contracting agency for transmission to the State DOT, the FHWA or the Wage and Hour Division of the Department of Labor for purposes of an investigation or audit of compliance with prevailing wage requirements. It is not a violation of this section for a prime contractor to require a subcontractor to provide addresses and social security numbers to the prime contractor for its own records, without weekly submission to the contracting agency.

(2) Each payroll submitted shall be accompanied by a "Statement of Compliance," signed by the contractor or

subcontractor or his or her agent who pays or supervises the payment of the persons employed under the contract and shall certify the following:

(i) That the payroll for the payroll period contains the information required to be provided under 29 CFR 5.5(a)(3)(ii), the appropriate information is being maintained under 29 CFR 5.5(a)(3)(i), and that such information is correct and complete;

(ii) That each laborer or mechanic (including each helper, apprentice, and trainee) employed on the contract during the payroll period has been paid the full weekly wages earned, without rebate, either directly or indirectly, and that no deductions have been made either directly or indirectly from the full wages earned, other than permissible deductions as set forth in 29 CFR part 3;

(iii) That each laborer or mechanic has been paid not less than the applicable wage rates and fringe benefits or cash equivalents for the classification of work performed, as specified in the applicable wage determination incorporated into the contract.

(3) The weekly submission of a properly executed certification set forth on the reverse side of Optional Form WH-347 shall satisfy the requirement for submission of the "Statement of Compliance" required by paragraph 3.b.(2) of this section.

(4) The falsification of any of the above certifications may subject the contractor or subcontractor to civil or criminal prosecution under 18 U.S.C. 1001 and 31 U.S.C. 231.

c. The contractor or subcontractor shall make the records required under paragraph 3.a. of this section available for inspection, copying, or transcription by authorized representatives of the contracting agency, the State DOT, the FHWA, or the Department of Labor, and shall permit such representatives to interview employees during working hours on the job. If the contractor or subcontractor fails to submit the required records or to make them available, the FHWA may, after written notice to the contractor, the contracting agency or the State DOT, take such action as may be necessary to cause the suspension of any further payment, advance, or guarantee of funds. Furthermore, failure to submit the required records upon request or to make such records available may be grounds for debarment action pursuant to 29 CFR 5.12.

4. Apprentices and trainees (29 CFR 5.5)

a. Apprentices (programs of the USDOL).

Apprentices will be permitted to work at less than the predetermined rate for the work they performed when they are employed pursuant to and individually registered in a bona fide apprenticeship program registered with the U.S. Department of Labor, Employment and Training Administration, Office of Apprenticeship Training, Employer and Labor Services, or with a State Apprenticeship Agency recognized by the Office, or if a person is employed in his or her first 90 days of probationary employment as an apprentice in such an apprenticeship program, who is not individually registered in the program, but who has been certified by the Office of Apprenticeship Training, Employer and Labor Services or a State

Apprenticeship Agency (where appropriate) to be eligible for probationary employment as an apprentice.

The allowable ratio of apprentices to journeymen on the job site in any craft classification shall not be greater than the ratio permitted to the contractor as to the entire work force under the registered program. Any worker listed on a payroll at an apprentice wage rate, who is not registered or otherwise employed as stated above, shall be paid not less than the applicable wage rate on the wage determination for the classification of work actually performed. In addition, any apprentice performing work on the job site in excess of the ratio permitted under the registered program shall be paid not less than the applicable wage rate on the wage determination for the work actually performed. Where a contractor is performing construction on a project in a locality other than that in which its program is registered, the ratios and wage rates (expressed in percentages of the journeyman's hourly rate) specified in the contractor's or subcontractor's registered program shall be observed.

Every apprentice must be paid at not less than the rate specified in the registered program for the apprentice's level of progress, expressed as a percentage of the journeymen hourly rate specified in the applicable wage determination. Apprentices shall be paid fringe benefits in accordance with the provisions of the apprenticeship program. If the apprenticeship program does not specify fringe benefits, apprentices must be paid the full amount of fringe benefits listed on the wage determination for the applicable classification. If the Administrator determines that a different practice prevails for the applicable apprentice classification, fringes shall be paid in accordance with that determination.

In the event the Office of Apprenticeship Training, Employer and Labor Services, or a State Apprenticeship Agency recognized by the Office, withdraws approval of an apprenticeship program, the contractor will no longer be permitted to utilize apprentices at less than the applicable predetermined rate for the work performed until an acceptable program is approved.

b. Trainees (programs of the USDOL).

Except as provided in 29 CFR 5.16, trainees will not be permitted to work at less than the predetermined rate for the work performed unless they are employed pursuant to and individually registered in a program which has received prior approval, evidenced by formal certification by the U.S. Department of Labor, Employment and Training Administration.

The ratio of trainees to journeymen on the job site shall not be greater than permitted under the plan approved by the Employment and Training Administration.

Every trainee must be paid at not less than the rate specified in the approved program for the trainee's level of progress, expressed as a percentage of the journeyman hourly rate specified in the applicable wage determination. Trainees shall be paid fringe benefits in accordance with the provisions of the trainee program. If the trainee program does not mention fringe benefits, trainees shall be paid the full amount of fringe benefits listed on the wage determination unless the Administrator of the Wage and Hour Division determines that there is an apprenticeship program associated with the

corresponding journeyman wage rate on the wage determination which provides for less than full fringe benefits for apprentices. Any employee listed on the payroll at a trainee rate who is not registered and participating in a training plan approved by the Employment and Training Administration shall be paid not less than the applicable wage rate on the wage determination for the classification of work actually performed. In addition, any trainee performing work on the job site in excess of the ratio permitted under the registered program shall be paid not less than the applicable wage rate on the wage determination for the work actually performed.

In the event the Employment and Training Administration withdraws approval of a training program, the contractor will no longer be permitted to utilize trainees at less than the applicable predetermined rate for the work performed until an acceptable program is approved.

c. Equal employment opportunity. The utilization of apprentices, trainees and journeymen under this part shall be in conformity with the equal employment opportunity requirements of Executive Order 11246, as amended, and 29 CFR part 30.

d. Apprentices and Trainees (programs of the U.S. DOT).

Apprentices and trainees working under apprenticeship and skill training programs which have been certified by the Secretary of Transportation as promoting EEO in connection with Federal-aid highway construction programs are not subject to the requirements of paragraph 4 of this Section IV. 23 CFR 230.111(e)(2). The straight time hourly wage rates for apprentices and trainees under such programs will be established by the particular programs. The ratio of apprentices and trainees to journeymen shall not be greater than permitted by the terms of the particular program.

5. Compliance with Copeland Act requirements. The contractor shall comply with the requirements of 29 CFR part 3, which are incorporated by reference in this contract as provided in 29 CFR 5.5.

6. Subcontracts. The contractor or subcontractor shall insert Form FHWA-1273 in any subcontracts and also require the subcontractors to include Form FHWA-1273 in any lower tier subcontracts. The prime contractor shall be responsible for the compliance by any subcontractor or lower tier subcontractor with all the contract clauses in 29 CFR 5.5.

7. Contract termination: debarment. A breach of the contract clauses in 29 CFR 5.5 may be grounds for termination of the contract, and for debarment as a contractor and a subcontractor as provided in 29 CFR 5.12.

8. Compliance with Davis-Bacon and Related Act requirements. All rulings and interpretations of the Davis-Bacon and Related Acts contained in 29 CFR parts 1, 3, and 5 are herein incorporated by reference in this contract as provided in 29 CFR 5.5.

9. Disputes concerning labor standards. As provided in 29 CFR 5.5, disputes arising out of the labor standards provisions of this contract shall not be subject to the general disputes clause of this contract. Such disputes shall be resolved in accordance with the procedures of the Department of Labor

set forth in 29 CFR parts 5, 6, and 7. Disputes within the meaning of this clause include disputes between the contractor (or any of its subcontractors) and the contracting agency, the U.S. Department of Labor, or the employees or their representatives.

10. Certification of eligibility (29 CFR 5.5)

a. By entering into this contract, the contractor certifies that neither it (nor he or she) nor any person or firm who has an interest in the contractor's firm is a person or firm ineligible to be awarded Government contracts by virtue of section 3(a) of the Davis-Bacon Act or 29 CFR 5.12(a)(1).

b. No part of this contract shall be subcontracted to any person or firm ineligible for award of a Government contract by virtue of section 3(a) of the Davis-Bacon Act or 29 CFR 5.12(a)(1).

c. The penalty for making false statements is prescribed in the U.S. Criminal Code, 18 U.S.C. 1001.

V. CONTRACT WORK HOURS AND SAFETY STANDARDS ACT

Pursuant to 29 CFR 5.5(b), the following clauses apply to any Federal-aid construction contract in an amount in excess of \$100,000 and subject to the overtime provisions of the Contract Work Hours and Safety Standards Act. These clauses shall be inserted in addition to the clauses required by 29 CFR 5.5(a) or 29 CFR 4.6. As used in this paragraph, the terms laborers and mechanics include watchmen and guards.

1. Overtime requirements. No contractor or subcontractor contracting for any part of the contract work which may require or involve the employment of laborers or mechanics shall require or permit any such laborer or mechanic in any workweek in which he or she is employed on such work to work in excess of forty hours in such workweek unless such laborer or mechanic receives compensation at a rate not less than one and one-half times the basic rate of pay for all hours worked in excess of forty hours in such workweek. 29 CFR 5.5.

2. Violation; liability for unpaid wages; liquidated damages. In the event of any violation of the clause set forth in paragraph 1 of this section, the contractor and any subcontractor responsible therefor shall be liable for the unpaid wages. In addition, such contractor and subcontractor shall be liable to the United States (in the case of work done under contract for the District of Columbia or a territory, to such District or to such territory), for liquidated damages. Such liquidated damages shall be computed with respect to each individual laborer or mechanic, including watchmen and guards, employed in violation of the clause set forth in paragraph 1 of this section, in the sum currently provided in 29 CFR 5.5(b)(2)* for each calendar day on which such individual was required or permitted to work in excess of the standard workweek of forty hours without payment of the overtime wages required by the clause set forth in paragraph 1 of this section. 29 CFR 5.5.

* \$27 as of January 23, 2019 (See 84 FR 213-01, 218) as may be adjusted annually by the Department of Labor; pursuant to the Federal Civil Penalties Inflation Adjustment Act of 1990).

3. Withholding for unpaid wages and liquidated damages.

The FHWA or the contacting agency shall upon its own action or upon written request of an authorized representative of the Department of Labor withhold or cause to be withheld, from any moneys payable on account of work performed by the contractor or subcontractor under any such contract or any other Federal contract with the same prime contractor, or any other federally-assisted contract subject to the Contract Work Hours and Safety Standards Act, which is held by the same prime contractor, such sums as may be determined to be necessary to satisfy any liabilities of such contractor or subcontractor for unpaid wages and liquidated damages as provided in the clause set forth in paragraph 2 of this section. 29 CFR 5.5.

4. Subcontracts. The contractor or subcontractor shall insert in any subcontracts the clauses set forth in paragraphs 1 through 4 of this section and also a clause requiring the subcontractors to include these clauses in any lower tier subcontracts. The prime contractor shall be responsible for compliance by any subcontractor or lower tier subcontractor with the clauses set forth in paragraphs 1 through 4 of this section. 29 CFR 5.5.

VI. SUBLETTING OR ASSIGNING THE CONTRACT

This provision is applicable to all Federal-aid construction contracts on the National Highway System pursuant to 23 CFR 635.116.

1. The contractor shall perform with its own organization contract work amounting to not less than 30 percent (or a greater percentage if specified elsewhere in the contract) of the total original contract price, excluding any specialty items designated by the contracting agency. Specialty items may be performed by subcontract and the amount of any such specialty items performed may be deducted from the total original contract price before computing the amount of work required to be performed by the contractor's own organization (23 CFR 635.116).

a. The term "perform work with its own organization" in paragraph 1 of Section VI refers to workers employed or leased by the prime contractor, and equipment owned or rented by the prime contractor, with or without operators. Such term does not include employees or equipment of a subcontractor or lower tier subcontractor, agents of the prime contractor, or any other assignees. The term may include payments for the costs of hiring leased employees from an employee leasing firm meeting all relevant Federal and State regulatory requirements. Leased employees may only be included in this term if the prime contractor meets all of the following conditions: (based on longstanding interpretation)

- (1) the prime contractor maintains control over the supervision of the day-to-day activities of the leased employees;
- (2) the prime contractor remains responsible for the quality of the work of the leased employees;
- (3) the prime contractor retains all power to accept or exclude individual employees from work on the project; and
- (4) the prime contractor remains ultimately responsible for the payment of predetermined minimum wages, the submission of payrolls, statements of compliance and all other Federal regulatory requirements.

b. "Specialty Items" shall be construed to be limited to work that requires highly specialized knowledge, abilities, or

equipment not ordinarily available in the type of contracting organizations qualified and expected to bid or propose on the contract as a whole and in general are to be limited to minor components of the overall contract. 23 CFR 635.102.

2. Pursuant to 23 CFR 635.116(a), the contract amount upon which the requirements set forth in paragraph (1) of Section VI is computed includes the cost of material and manufactured products which are to be purchased or produced by the contractor under the contract provisions.

3. Pursuant to 23 CFR 635.116(c), the contractor shall furnish (a) a competent superintendent or supervisor who is employed by the firm, has full authority to direct performance of the work in accordance with the contract requirements, and is in charge of all construction operations (regardless of who performs the work) and (b) such other of its own organizational resources (supervision, management, and engineering services) as the contracting officer determines is necessary to assure the performance of the contract.

4. No portion of the contract shall be sublet, assigned or otherwise disposed of except with the written consent of the contracting officer, or authorized representative, and such consent when given shall not be construed to relieve the contractor of any responsibility for the fulfillment of the contract. Written consent will be given only after the contracting agency has assured that each subcontract is evidenced in writing and that it contains all pertinent provisions and requirements of the prime contract. (based on longstanding interpretation of 23 CFR 635.116).

5. The 30-percent self-performance requirement of paragraph (1) is not applicable to design-build contracts; however, contracting agencies may establish their own self-performance requirements. 23 CFR 635.116(d).

VII. SAFETY: ACCIDENT PREVENTION

This provision is applicable to all Federal-aid construction contracts and to all related subcontracts.

1. In the performance of this contract the contractor shall comply with all applicable Federal, State, and local laws governing safety, health, and sanitation (23 CFR Part 635). The contractor shall provide all safeguards, safety devices and protective equipment and take any other needed actions as it determines, or as the contracting officer may determine, to be reasonably necessary to protect the life and health of employees on the job and the safety of the public and to protect property in connection with the performance of the work covered by the contract. 23 CFR 635.108.

2. It is a condition of this contract, and shall be made a condition of each subcontract, which the contractor enters into pursuant to this contract, that the contractor and any subcontractor shall not permit any employee, in performance of the contract, to work in surroundings or under conditions which are unsanitary, hazardous or dangerous to his/her health or safety, as determined under construction safety and health standards (29 CFR Part 1926) promulgated by the Secretary of Labor, in accordance with Section 107 of the Contract Work Hours and Safety Standards Act (40 U.S.C. 3704). 29 CFR 1926.10.

3. Pursuant to 29 CFR 1926.3, it is a condition of this contract that the Secretary of Labor or authorized representative thereof, shall have right of entry to any site of contract performance to inspect or investigate the matter of compliance

with the construction safety and health standards and to carry out the duties of the Secretary under Section 107 of the Contract Work Hours and Safety Standards Act (40 U.S.C. 3704).

VIII. FALSE STATEMENTS CONCERNING HIGHWAY PROJECTS

This provision is applicable to all Federal-aid construction contracts and to all related subcontracts.

In order to assure high quality and durable construction in conformity with approved plans and specifications and a high degree of reliability on statements and representations made by engineers, contractors, suppliers, and workers on Federal-aid highway projects, it is essential that all persons concerned with the project perform their functions as carefully, thoroughly, and honestly as possible. Willful falsification, distortion, or misrepresentation with respect to any facts related to the project is a violation of Federal law. To prevent any misunderstanding regarding the seriousness of these and similar acts, Form FHWA-1022 shall be posted on each Federal-aid highway project (23 CFR Part 635) in one or more places where it is readily available to all persons concerned with the project:

18 U.S.C. 1020 reads as follows:

"Whoever, being an officer, agent, or employee of the United States, or of any State or Territory, or whoever, whether a person, association, firm, or corporation, knowingly makes any false statement, false representation, or false report as to the character, quality, quantity, or cost of the material used or to be used, or the quantity or quality of the work performed or to be performed, or the cost thereof in connection with the submission of plans, maps, specifications, contracts, or costs of construction on any highway or related project submitted for approval to the Secretary of Transportation; or

Whoever knowingly makes any false statement, false representation, false report or false claim with respect to the character, quality, quantity, or cost of any work performed or to be performed, or materials furnished or to be furnished, in connection with the construction of any highway or related project approved by the Secretary of Transportation; or

Whoever knowingly makes any false statement or false representation as to material fact in any statement, certificate, or report submitted pursuant to provisions of the Federal-aid Roads Act approved July 11, 1916, (39 Stat. 355), as amended and supplemented;

Shall be fined under this title or imprisoned not more than 5 years or both."

IX. IMPLEMENTATION OF CLEAN AIR ACT AND FEDERAL WATER POLLUTION CONTROL ACT (42 U.S.C. 7606; 2 CFR 200.88; EO 11738)

This provision is applicable to all Federal-aid construction contracts in excess of \$150,000 and to all related subcontracts. 48 CFR 2.101; 2 CFR 200.326.

By submission of this bid/proposal or the execution of this contract or subcontract, as appropriate, the bidder, proposer, Federal-aid construction contractor, subcontractor, supplier, or vendor agrees to comply with all applicable standards, orders

or regulations issued pursuant to the Clean Air Act (42 U.S.C. 7401-7671q) and the Federal Water Pollution Control Act, as amended (33 U.S.C. 1251-1387). Violations must be reported to the Federal Highway Administration and the Regional Office of the Environmental Protection Agency. 2 CFR Part 200, Appendix II.

The contractor agrees to include or cause to be included the requirements of this Section in every subcontract, and further agrees to take such action as the contracting agency may direct as a means of enforcing such requirements. 2 CFR 200.326.

X. CERTIFICATION REGARDING DEBARMENT, SUSPENSION, INELIGIBILITY AND VOLUNTARY EXCLUSION

This provision is applicable to all Federal-aid construction contracts, design-build contracts, subcontracts, lower-tier subcontracts, purchase orders, lease agreements, consultant contracts or any other covered transaction requiring FHWA approval or that is estimated to cost \$25,000 or more – as defined in 2 CFR Parts 180 and 1200. 2 CFR 180.220 and 1200.220.

1. Instructions for Certification – First Tier Participants:

a. By signing and submitting this proposal, the prospective first tier participant is providing the certification set out below.

b. The inability of a person to provide the certification set out below will not necessarily result in denial of participation in this covered transaction. The prospective first tier participant shall submit an explanation of why it cannot provide the certification set out below. The certification or explanation will be considered in connection with the department or agency's determination whether to enter into this transaction. However, failure of the prospective first tier participant to furnish a certification or an explanation shall disqualify such a person from participation in this transaction. 2 CFR 180.320.

c. The certification in this clause is a material representation of fact upon which reliance was placed when the contracting agency determined to enter into this transaction. If it is later determined that the prospective participant knowingly rendered an erroneous certification, in addition to other remedies available to the Federal Government, the contracting agency may terminate this transaction for cause of default. 2 CFR 180.325.

d. The prospective first tier participant shall provide immediate written notice to the contracting agency to whom this proposal is submitted if any time the prospective first tier participant learns that its certification was erroneous when submitted or has become erroneous by reason of changed circumstances. 2 CFR 180.345 and 180.350.

e. The terms "covered transaction," "debarred," "suspended," "ineligible," "participant," "person," "principal," and "voluntarily excluded," as used in this clause, are defined in 2 CFR Parts 180, Subpart I, 180.900-180.1020, and 1200. "First Tier Covered Transactions" refers to any covered transaction between a recipient or subrecipient of Federal funds and a participant (such as the prime or general contract). "Lower Tier Covered Transactions" refers to any covered transaction under a First Tier Covered Transaction (such as subcontracts). "First Tier Participant" refers to the participant

who has entered into a covered transaction with a recipient or subrecipient of Federal funds (such as the prime or general contractor). "Lower Tier Participant" refers any participant who has entered into a covered transaction with a First Tier Participant or other Lower Tier Participants (such as subcontractors and suppliers).

f. The prospective first tier participant agrees by submitting this proposal that, should the proposed covered transaction be entered into, it shall not knowingly enter into any lower tier covered transaction with a person who is debarred, suspended, declared ineligible, or voluntarily excluded from participation in this covered transaction, unless authorized by the department or agency entering into this transaction. 2 CFR 180.330.

g. The prospective first tier participant further agrees by submitting this proposal that it will include the clause titled "Certification Regarding Debarment, Suspension, Ineligibility and Voluntary Exclusion-Lower Tier Covered Transactions," provided by the department or contracting agency, entering into this covered transaction, without modification, in all lower tier covered transactions and in all solicitations for lower tier covered transactions exceeding the \$25,000 threshold. 2 CFR 180.220 and 180.300.

h. A participant in a covered transaction may rely upon a certification of a prospective participant in a lower tier covered transaction that is not debarred, suspended, ineligible, or voluntarily excluded from the covered transaction, unless it knows that the certification is erroneous. 2 CFR 180.300; 180.320, and 180.325. A participant is responsible for ensuring that its principals are not suspended, debarred, or otherwise ineligible to participate in covered transactions. 2 CFR 180.335. To verify the eligibility of its principals, as well as the eligibility of any lower tier prospective participants, each participant may, but is not required to, check the System for Award Management website (<https://www.sam.gov/>). 2 CFR 180.300, 180.320, and 180.325.

i. Nothing contained in the foregoing shall be construed to require the establishment of a system of records in order to render in good faith the certification required by this clause. The knowledge and information of the prospective participant is not required to exceed that which is normally possessed by a prudent person in the ordinary course of business dealings.

j. Except for transactions authorized under paragraph (f) of these instructions, if a participant in a covered transaction knowingly enters into a lower tier covered transaction with a person who is suspended, debarred, ineligible, or voluntarily excluded from participation in this transaction, in addition to other remedies available to the Federal Government, the department or agency may terminate this transaction for cause or default. 2 CFR 180.325.

2. Certification Regarding Debarment, Suspension, Ineligibility and Voluntary Exclusion – First Tier Participants:

a. The prospective first tier participant certifies to the best of its knowledge and belief, that it and its principals:

(1) Are not presently debarred, suspended, proposed for debarment, declared ineligible, or voluntarily excluded from participating in covered transactions by any Federal department or agency, 2 CFR 180.335;.

(2) Have not within a three-year period preceding this proposal been convicted of or had a civil judgment rendered against them for commission of fraud or a criminal offense in connection with obtaining, attempting to obtain, or performing a public (Federal, State, or local) transaction or contract under a public transaction; violation of Federal or State antitrust statutes or commission of embezzlement, theft, forgery, bribery, falsification or destruction of records, making false statements, or receiving stolen property, 2 CFR 180.800;

(3) Are not presently indicted for or otherwise criminally or civilly charged by a governmental entity (Federal, State or local) with commission of any of the offenses enumerated in paragraph (a)(2) of this certification, 2 CFR 180.700 and 180.800; and

(4) Have not within a three-year period preceding this application/proposal had one or more public transactions (Federal, State or local) terminated for cause or default. 2 CFR 180.335(d).

(5) Are not a corporation that has been convicted of a felony violation under any Federal law within the two-year period preceding this proposal (USDOT Order 4200.6 implementing appropriations act requirements); and

(6) Are not a corporation with any unpaid Federal tax liability that has been assessed, for which all judicial and administrative remedies have been exhausted, or have lapsed, and that is not being paid in a timely manner pursuant to an agreement with the authority responsible for collecting the tax liability (USDOT Order 4200.6 implementing appropriations act requirements).

b. Where the prospective participant is unable to certify to any of the statements in this certification, such prospective participant should attach an explanation to this proposal. 2 CFR 180.335 and 180.340.

3. Instructions for Certification - Lower Tier Participants:

(Applicable to all subcontracts, purchase orders, and other lower tier transactions requiring prior FHWA approval or estimated to cost \$25,000 or more - 2 CFR Parts 180 and 1200). 2 CFR 180.220 and 1200.220.

a. By signing and submitting this proposal, the prospective lower tier participant is providing the certification set out below.

b. The certification in this clause is a material representation of fact upon which reliance was placed when this transaction was entered into. If it is later determined that the prospective lower tier participant knowingly rendered an erroneous certification, in addition to other remedies available to the Federal Government, the department, or agency with which this transaction originated may pursue available remedies, including suspension and/or debarment.

c. The prospective lower tier participant shall provide immediate written notice to the person to which this proposal is submitted if at any time the prospective lower tier participant learns that its certification was erroneous by reason of changed circumstances. 2 CFR 180.365.

d. The terms "covered transaction," "debarred," "suspended," "ineligible," "participant," "person," "principal," and "voluntarily excluded," as used in this clause, are defined in 2 CFR Parts 180, Subpart I, 180.900 – 180.1020, and 1200. You may contact the person to which this proposal is

submitted for assistance in obtaining a copy of those regulations. "First Tier Covered Transactions" refers to any covered transaction between a recipient or subrecipient of Federal funds and a participant (such as the prime or general contract). "Lower Tier Covered Transactions" refers to any covered transaction under a First Tier Covered Transaction (such as subcontracts). "First Tier Participant" refers to the participant who has entered into a covered transaction with a recipient or subrecipient of Federal funds (such as the prime or general contractor). "Lower Tier Participant" refers any participant who has entered into a covered transaction with a First Tier Participant or other Lower Tier Participants (such as subcontractors and suppliers).

e. The prospective lower tier participant agrees by submitting this proposal that, should the proposed covered transaction be entered into, it shall not knowingly enter into any lower tier covered transaction with a person who is debarred, suspended, declared ineligible, or voluntarily excluded from participation in this covered transaction, unless authorized by the department or agency with which this transaction originated. 2 CFR 1200.220 and 1200.332.

f. The prospective lower tier participant further agrees by submitting this proposal that it will include this clause titled "Certification Regarding Debarment, Suspension, Ineligibility and Voluntary Exclusion-Lower Tier Covered Transaction," without modification, in all lower tier covered transactions and in all solicitations for lower tier covered transactions exceeding the \$25,000 threshold. 2 CFR 180.220 and 1200.220.

g. A participant in a covered transaction may rely upon a certification of a prospective participant in a lower tier covered transaction that is not debarred, suspended, ineligible, or voluntarily excluded from the covered transaction, unless it knows that the certification is erroneous. A participant is responsible for ensuring that its principals are not suspended, debarred, or otherwise ineligible to participate in covered transactions. To verify the eligibility of its principals, as well as the eligibility of any lower tier prospective participants, each participant may, but is not required to, check the System for Award Management website (<https://www.sam.gov/>), which is compiled by the General Services Administration. 2 CFR 180.300, 180.320, 180.330, and 180.335.

h. Nothing contained in the foregoing shall be construed to require establishment of a system of records in order to render in good faith the certification required by this clause. The knowledge and information of participant is not required to exceed that which is normally possessed by a prudent person in the ordinary course of business dealings.

i. Except for transactions authorized under paragraph e of these instructions, if a participant in a covered transaction knowingly enters into a lower tier covered transaction with a person who is suspended, debarred, ineligible, or voluntarily excluded from participation in this transaction, in addition to other remedies available to the Federal Government, the department or agency with which this transaction originated may pursue available remedies, including suspension and/or debarment. 2 CFR 180.325.

Certification Regarding Debarment, Suspension, Ineligibility and Voluntary Exclusion--Lower Tier Participants:

1. The prospective lower tier participant certifies, by submission of this proposal, that neither it nor its principals:

(a) is presently debarred, suspended, proposed for debarment, declared ineligible, or voluntarily excluded from participating in covered transactions by any Federal department or agency, 2 CFR 180.355;

(b) is a corporation that has been convicted of a felony violation under any Federal law within the two-year period preceding this proposal (USDOT Order 4200.6 implementing appropriations act requirements); and

(c) is a corporation with any unpaid Federal tax liability that has been assessed, for which all judicial and administrative remedies have been exhausted, or have lapsed, and that is not being paid in a timely manner pursuant to an agreement with the authority responsible for collecting the tax liability. (USDOT Order 4200.6 implementing appropriations act requirements)

2. Where the prospective lower tier participant is unable to certify to any of the statements in this certification, such prospective participant should attach an explanation to this proposal.

XI. CERTIFICATION REGARDING USE OF CONTRACT FUNDS FOR LOBBYING

This provision is applicable to all Federal-aid construction contracts and to all related subcontracts which exceed \$100,000. 49 CFR Part 20, App. A.

1. The prospective participant certifies, by signing and submitting this bid or proposal, to the best of his or her knowledge and belief, that:

a. No Federal appropriated funds have been paid or will be paid, by or on behalf of the undersigned, to any person for influencing or attempting to influence an officer or employee of any Federal agency, a Member of Congress, an officer or employee of Congress, or an employee of a Member of Congress in connection with the awarding of any Federal contract, the making of any Federal grant, the making of any Federal loan, the entering into of any cooperative agreement, and the extension, continuation, renewal, amendment, or modification of any Federal contract, grant, loan, or cooperative agreement.

b. If any funds other than Federal appropriated funds have been paid or will be paid to any person for influencing or attempting to influence an officer or employee of any Federal agency, a Member of Congress, an officer or employee of Congress, or an employee of a Member of Congress in connection with this Federal contract, grant, loan, or cooperative agreement, the undersigned shall complete and submit Standard Form-LLL, "Disclosure Form to Report Lobbying," in accordance with its instructions.

2. This certification is a material representation of fact upon which reliance was placed when this transaction was made or entered into. Submission of this certification is a prerequisite for making or entering into this transaction imposed by 31 U.S.C. 1352. Any person who fails to file the required certification shall be subject to a civil penalty of not less than \$10,000 and not more than \$100,000 for each such failure.

3. The prospective participant also agrees by submitting its bid or proposal that the participant shall require that the language of this certification be included in all lower tier

subcontracts, which exceed \$100,000 and that all such recipients shall certify and disclose accordingly.

XII. USE OF UNITED STATES-FLAG VESSELS:

This provision is applicable to all Federal-aid construction contracts, design-build contracts, subcontracts, lower-tier subcontracts, purchase orders, lease agreements, or any other covered transaction. 46 CFR Part 381.

This requirement applies to material or equipment that is acquired for a specific Federal-aid highway project. 46 CFR 381.7. It is not applicable to goods or materials that come into inventories independent of an FHWA funded-contract.

When oceanic shipments (or shipments across the Great Lakes) are necessary for materials or equipment acquired for a specific Federal-aid construction project, the bidder, proposer, contractor, subcontractor, or vendor agrees:

1. To utilize privately owned United States-flag commercial vessels to ship at least 50 percent of the gross tonnage (computed separately for dry bulk carriers, dry cargo liners, and tankers) involved, whenever shipping any equipment, material, or commodities pursuant to this contract, to the extent such vessels are available at fair and reasonable rates for United States-flag commercial vessels. 46 CFR 381.7.
2. To furnish within 20 days following the date of loading for shipments originating within the United States or within 30 working days following the date of loading for shipments originating outside the United States, a legible copy of a rated, 'on-board' commercial ocean bill-of-lading in English for each shipment of cargo described in paragraph (b)(1) of this section to both the Contracting Officer (through the prime contractor in the case of subcontractor bills-of-lading) and to the Office of Cargo and Commercial Sealift (MAR-620), Maritime Administration, Washington, DC 20590. (MARAD requires copies of the ocean carrier's (master) bills of lading, certified onboard, dated, with rates and charges. These bills of lading may contain business sensitive information and therefore may be submitted directly to MARAD by the Ocean Transportation Intermediary on behalf of the contractor). 46 CFR 381.7.

**ATTACHMENT A - EMPLOYMENT AND MATERIALS
PREFERENCE FOR APPALACHIAN DEVELOPMENT
HIGHWAY SYSTEM OR APPALACHIAN LOCAL ACCESS
ROAD CONTRACTS** (23 CFR 633, Subpart B, Appendix B)

This provision is applicable to all Federal-aid projects funded under the Appalachian Regional Development Act of 1965.

1. During the performance of this contract, the contractor undertaking to do work which is, or reasonably may be, done as on-site work, shall give preference to qualified persons who regularly reside in the labor area as designated by the DOL wherein the contract work is situated, or the subregion, or the Appalachian counties of the State wherein the contract work is situated, except:

a. To the extent that qualified persons regularly residing in the area are not available.

b. For the reasonable needs of the contractor to employ supervisory or specially experienced personnel necessary to assure an efficient execution of the contract work.

c. For the obligation of the contractor to offer employment to present or former employees as the result of a lawful collective bargaining contract, provided that the number of nonresident persons employed under this subparagraph (1c) shall not exceed 20 percent of the total number of employees employed by the contractor on the contract work, except as provided in subparagraph (4) below.

2. The contractor shall place a job order with the State Employment Service indicating (a) the classifications of the laborers, mechanics and other employees required to perform the contract work, (b) the number of employees required in each classification, (c) the date on which the participant estimates such employees will be required, and (d) any other pertinent information required by the State Employment Service to complete the job order form. The job order may be placed with the State Employment Service in writing or by telephone. If during the course of the contract work, the information submitted by the contractor in the original job order is substantially modified, the participant shall promptly notify the State Employment Service.

3. The contractor shall give full consideration to all qualified job applicants referred to him by the State Employment Service. The contractor is not required to grant employment to any job applicants who, in his opinion, are not qualified to perform the classification of work required.

4. If, within one week following the placing of a job order by the contractor with the State Employment Service, the State Employment Service is unable to refer any qualified job applicants to the contractor, or less than the number requested, the State Employment Service will forward a certificate to the contractor indicating the unavailability of applicants. Such certificate shall be made a part of the contractor's permanent project records. Upon receipt of this certificate, the contractor may employ persons who do not normally reside in the labor area to fill positions covered by the certificate, notwithstanding the provisions of subparagraph (1c) above.

5. The provisions of 23 CFR 633.207(e) allow the contracting agency to provide a contractual preference for the use of mineral resource materials native to the Appalachian region.

6. The contractor shall include the provisions of Sections 1 through 4 of this Attachment A in every subcontract for work which is, or reasonably may be, done as on-site work.

**KENTUCKY TRANSPORTATION CABINET
DEPARTMENT OF HIGHWAYS**

**EMPLOYMENT REQUIREMENTS
RELATING TO
NONDISCRIMINATION OF EMPLOYEES
(APPLICABLE TO FEDERAL-AID SYSTEM CONTRACTS)**

**AN ACT OF THE KENTUCKY GENERAL ASSEMBLY
TO PREVENT DISCRIMINATION IN EMPLOYMENT**

**KRS CHAPTER 344
EFFECTIVE JUNE 16, 1972**

The contract on this project, in accordance with KRS Chapter 344, provides that during the performance of this contract, the contractor agrees as follows:

1. The contractor shall not fail or refuse to hire, or shall not discharge any individual, or otherwise discriminate against an individual with respect to his compensation, terms, conditions, or privileges of employment, because of such individual's race, color, religion, national origin, sex, disability or age (forty and above); or limit, segregate, or classify his employees in any way which would deprive or tend to deprive an individual of employment opportunities or otherwise adversely affect his status as an employee, because of such individual's race, color, religion, national origin, sex, disability or age forty (40) and over. The contractor agrees to post in conspicuous places, available to employees and applicants for employment, notices to be provided setting forth the provisions of this nondiscrimination clause.

2. The contractor shall not print or publish or cause to be printed or published a notice or advertisement relating to employment by such an employer or membership in or any classification or referral for employment by the employment agency, indicating any preference, limitation, specification, or discrimination, based on race, color, religion, national origin, sex, or age forty (40) and over, or because the person is a qualified individual with a disability, except that such a notice or advertisement may indicate a preference, limitation, or specification based on religion, national origin, sex, or age forty (40) and over, or because the person is a qualified individual with a disability, when religion, national origin, sex, or age forty (40) and over, or because the person is a qualified individual with a disability, is a bona fide occupational qualification for employment.

3. If the contractor is in control of apprenticeship or other training or retraining, including on-the-job training programs, he shall not discriminate against an individual because of his race, color, religion, national origin, sex, disability or age forty (40) and over, in admission to, or employment in any program established to provide apprenticeship or other training.

4. The contractor will send to each labor union or representative of workers with which he has a collective bargaining agreement or other contract or understanding, a notice to be provided advising the said labor union or workers' representative of the contractor's commitments under this section, and shall post copies of the notice in conspicuous places available to employees and applicants for employment. The contractor will take such action with respect to any subcontract or purchase order as the administering agency may direct as a means of enforcing such provisions, including sanctions for non-compliance.

Revised: January 25, 2017

Standard Title VI/Non-Discrimination Assurances

During the performance of this contract, the contractor, for itself, its assignees, and successors in interest (hereinafter referred to as the "contractor") agrees as follows:

1. **Compliance with Regulations:** The contractor (hereinafter includes consultants) will comply with the Acts and the Regulations relative to Non-discrimination in Federally-assisted programs of the U.S. Department of Transportation, **Federal Highway Administration**, as they may be amended from time to time, which are herein incorporated by reference and made a part of this contract.
2. **Non-discrimination:** The contractor, with regard to the work performed by it during the contract, will not discriminate on the grounds of race, color, or national origin in the selection and retention of subcontractors, including procurements of materials and leases of equipment. The contractor will not participate directly or indirectly in the discrimination prohibited by the Acts and the Regulations, including employment practices when the contract covers any activity, project, or program set forth in Appendix B of 49 CFR Part 21.
3. **Solicitations for Subcontracts, Including Procurements of Materials and Equipment:** In all solicitations, either by competitive bidding, or negotiation made by the contractor for work to be performed under a subcontract, including procurements of materials, or leases of equipment, each potential subcontractor or supplier will be notified by the contractor of the contractor's obligations under this contract and the Acts and the Regulations relative to Non-discrimination on the grounds of race, color, or national origin.
4. **Information and Reports:** The contractor will provide all information and reports required by the Acts, the Regulations, and directives issued pursuant thereto and will permit access to its books, records, accounts, other sources of information, and its facilities as may be determined by the Recipient or the **Federal Highway Administration** to be pertinent to ascertain compliance with such Acts, Regulations, and instructions. Where any information required of a contractor is in the exclusive possession of another who fails or refuses to furnish the information, the contractor will so certify to the Recipient or the **Federal Highway Administration**, as appropriate, and will set forth what efforts it has made to obtain the information.
5. **Sanctions for Noncompliance:** In the event of a contractor's noncompliance with the Non-discrimination provisions of this contract, the Recipient will impose such contract sanctions as it or the **Federal Highway Administration** may determine to be appropriate, including, but not limited to:
 - a. withholding payments to the contractor under the contract until the contractor complies; and/or
 - b. cancelling, terminating, or suspending a contract, in whole or in part.
6. **Incorporation of Provisions:** The contractor will include the provisions of paragraphs one through six in every subcontract, including procurements of materials and leases of equipment, unless exempt by the Acts, the Regulations and directives issued pursuant thereto. The contractor will take action with respect to any subcontract or procurement as the Recipient or the **Federal Highway Administration** may direct as a means of enforcing such provisions including sanctions for noncompliance. Provided, that if the contractor becomes involved in, or is threatened with litigation by a subcontractor, or supplier because of such direction, the contractor may request the Recipient to enter into any litigation to protect the interests of the Recipient. In addition, the contractor may request the United States to enter into the litigation to protect the interests of the United States.

Standard Title VI/Non-Discrimination Statutes and Authorities

During the performance of this contract, the contractor, for itself, its assignees, and successors in interest (hereinafter referred to as the “contractor”) agrees to comply with the following non-discrimination statutes and authorities; including but not limited to:

- Title VI of the Civil Rights Act of 1964 (42 U.S.C. § 2000d *et seq.*, 78 stat. 252), (prohibits discrimination on the basis of race, color, national origin); and 49 CFR Part 21;
- The Uniform Relocation Assistance and Real Property Acquisition Policies Act of 1970, (42 U.S.C. § 4601), (prohibits unfair treatment of persons displaced or whose property has been acquired because of Federal or Federal-aid programs and projects);
- Federal-Aid Highway Act of 1973, (23 U.S.C. § 324 *et seq.*), (prohibits discrimination on the basis of sex);
- Section 504 of the Rehabilitation Act of 1973, (29 U.S.C. § 794 *et seq.*), as amended, (prohibits discrimination on the basis of disability); and 49 CFR Part 27;
- The Age Discrimination Act of 1975, as amended, (42 U.S.C. § 6101 *et seq.*), (prohibits discrimination on the basis of age);
- Airport and Airway Improvement Act of 1982, (49 USC § 471, Section 47123), as amended, (prohibits discrimination based on race, creed, color, national origin, or sex);
- The Civil Rights Restoration Act of 1987, (PL 100-209), (Broadened the scope, coverage and applicability of Title VI of the Civil Rights Act of 1964, The Age Discrimination Act of 1975 and Section 504 of the Rehabilitation Act of 1973, by expanding the definition of the terms “programs or activities” to include all of the programs or activities of the Federal-aid recipients, sub-recipients and contractors, whether such programs or activities are Federally funded or not);
- Titles II and III of the Americans with Disabilities Act, which prohibit discrimination on the basis of disability in the operation of public entities, public and private transportation systems, places of public accommodation, and certain testing entities (42 U.S.C. §§ 12131 -- 12189) as implemented by Department of Transportation regulations at 49 C.F.R. parts 37 and 38;
- The Federal Aviation Administration’s Non-discrimination statute (49 U.S.C. § 47123) (prohibits discrimination on the basis of race, color, national origin, and sex);
- Executive Order 12898, Federal Actions to Address Environmental Justice in Minority Populations and Low-Income Populations, which ensures non-discrimination against minority populations by discouraging programs, policies, and activities with disproportionately high and adverse human health or environmental effects on minority and low-income populations;
- Executive Order 13166, Improving Access to Services for Persons with Limited English Proficiency, and resulting agency guidance, national origin discrimination includes discrimination because of limited English proficiency (LEP). To ensure compliance with Title VI, you must take reasonable steps to ensure that LEP persons have meaningful access to your programs (70 Fed. Reg. at 74087 to 74100);
- Title IX of the Education Amendments of 1972, as amended, which prohibits you from discriminating because of sex in education programs or activities (20 U.S.C. 1681 *et seq.*)

EXECUTIVE BRANCH CODE OF ETHICS

In the 1992 regular legislative session, the General Assembly passed and Governor Brereton Jones signed Senate Bill 63 (codified as KRS 11A), the Executive Branch Code of Ethics, which states, in part:

KRS 11A.040 (7) provides:

No present or former public servant shall, within six (6) months following termination of his office or employment, accept employment, compensation, or other economic benefit from any person or business that contracts or does business with, or is regulated by, the state in matters in which he was directly involved during the last thirty-six (36) months of his tenure. This provision shall not prohibit an individual from returning to the same business, firm, occupation, or profession in which he was involved prior to taking office or beginning his term of employment, or for which he received, prior to his state employment, a professional degree or license, provided that, for a period of six (6) months, he personally refrains from working on any matter in which he was directly involved during the last thirty-six (36) months of his tenure in state government. This subsection shall not prohibit the performance of ministerial functions, including but not limited to filing tax returns, filing applications for permits or licenses, or filing incorporation papers, nor shall it prohibit the former officer or public servant from receiving public funds disbursed through entitlement programs.

KRS 11A.040 (9) states:

A former public servant shall not represent a person or business before a state agency in a matter in which the former public servant was directly involved during the last thirty-six (36) months of his tenure, for a period of one (1) year after the latter of:

- a) The date of leaving office or termination of employment; or
- b) The date the term of office expires to which the public servant was elected.

This law is intended to promote public confidence in the integrity of state government and to declare as public policy the idea that state employees should view their work as a public trust and not as a way to obtain private benefits.

If you have worked for the executive branch of state government within the past six months, you may be subject to the law's prohibitions. The law's applicability may be different if you hold elected office or are contemplating representation of another before a state agency.

Also, if you are affiliated with a firm which does business with the state and which employs former state executive-branch employees, you should be aware that the law may apply to them.

In case of doubt, the law permits you to request an advisory opinion from the Executive Branch Ethics Commission, 1025 Capital Center Drive, Suite 104, Frankfort, Kentucky 40601; telephone (502) 564-7954.

Revised: May 23, 2022

"General Decision Number: KY20220107 02/25/2022

Superseded General Decision Number: KY20210107

State: Kentucky

Construction Type: Highway

Counties: Adair, Barren, Bell, Breathitt, Casey, Clay, Clinton, Cumberland, Estill, Floyd, Garrard, Green, Harlan, Hart, Jackson, Johnson, Knott, Knox, Laurel, Lawrence, Lee, Leslie, Letcher, Lincoln, Magoffin, Martin, McCreary, Menifee, Metcalfe, Monroe, Morgan, Owsley, Perry, Pike, Powell, Pulaski, Rockcastle, Russell, Taylor, Wayne, Whitley and Wolfe Counties in Kentucky.

HIGHWAY CONSTRUCTION PROJECTS

Note: Contracts subject to the Davis-Bacon Act are generally required to pay at least the applicable minimum wage rate required under Executive Order 14026 or Executive Order 13658. Please note that these Executive Orders apply to covered contracts entered into by the federal government that are subject to the Davis-Bacon Act itself, but do not apply to contracts subject only to the Davis-Bacon Related Acts, including those set forth at 29 CFR 5.1(a)(2)-(60).

<p>If the contract is entered into on or after January 30, 2022, or the contract is renewed or extended (e.g., an option is exercised) on or after January 30, 2022:</p>	<ul style="list-style-type: none"> . Executive Order 14026 generally applies to the contract. . The contractor must pay all covered workers at least \$15.00 per hour (or the applicable wage rate listed on this wage determination, if it is higher) for all hours spent performing on the contract in 2022.
<p>If the contract was awarded on or between January 1, 2015 and January 29, 2022, and the contract is not renewed or extended on or after January 30, 2022:</p>	<ul style="list-style-type: none"> . Executive Order 13658 generally applies to the contract. . The contractor must pay all covered workers at least \$11.25 per hour (or the applicable wage rate listed on this wage determination, if it is higher) for all hours spent performing on that contract in 2022.

The applicable Executive Order minimum wage rate will be adjusted annually. If this contract is covered by one of the Executive Orders and a classification considered necessary for performance of work on the contract does not appear on this wage determination, the contractor must still submit a conformance request.

Additional information on contractor requirements and worker protections under the Executive Orders is available at

<https://www.dol.gov/agencies/whd/government-contracts>.

Modification Number	Publication Date
0	01/07/2022
1	02/25/2022

SUKY2015-047 10/20/2015

	Rates	Fringes
BOILERMAKER.....	\$ 24.65	12.94
BRICKLAYER		
Bricklayer.....	\$ 22.90	8.50
Stone Mason.....	\$ 21.50	8.50
CARPENTER		
Carpenter.....	\$ 24.90	14.50
Piledriver.....	\$ 24.55	14.50
CEMENT MASON.....	\$ 21.25	8.50
ELECTRICIAN		
Electrician.....	\$ 29.36	10.55
Equipment Operator.....	\$ 26.90	10.31
Groundsman.....	\$ 17.79	8.51
Lineman.....	\$ 30.09	10.94
IRONWORKER.....		
IRONWORKER.....	\$ 27.56	20.57
LABORER		
Group 1.....	\$ 21.80	12.36
Group 2.....	\$ 22.05	12.36
Group 3.....	\$ 22.10	12.36
Group 4.....	\$ 22.70	12.36

When workmen are required to work from bosum chairs, trusses, stacks, tanks, scaffolds, catwalks, radio and T.V. towers, structural steel (open, unprotected, unfloored raw steel), and bridges or similar hazardous locations where workmen are subject to fall, except where using JLG's and bucket trucks up to 75 feet: Add 25% to workman's base rate for 50 to 75 feet, and add 50% to workman's base rate for over 75 feet.

GROUP 1: Aging and Curing of Concrete (Any Mode or Method), Asbestos Abatement Worker, Asphalt Plant Laborers, Asphalt Laborers, Batch Truck Dumpers, Carpenter Tenders, Cement Mason Tenders, Cleaning of Machines, Concrete Laborers, Demolition Laborers, Dredging Laborers, Drill Tender, Environmental Laborer - Nuclear, Radiation, Toxic and Hazardous Waste - Level D, Flagmen, Grade Checkers, All Hand Digging and Hand Back Filling, Highway Marker Placers, Landscaping Laborers, Mesh Handlers and Placers, Puddler, Railroad Laborers, Rip-rap and Grouters, Right of Way Laborers, Sign, Guard Rail and Fence Installers (All Types), Signalmen, Sound Barrier Installer, Storm and Sanitary Sewer Laborers, Swampers, Truck Spotters and Dumpers, Wrecking of Concrete Forms, General Cleanup

GROUP 2: Batter Board Men (Sanitary and Storm Sewer), Brickmason Tenders, Mortar Mixer Operator, Scaffold Builders, Burner and Welder, Bushammers, Chain Saw Operator, Concrete Saw Operators, Deckhand Scow Man, Dry Cement Handlers, Environmental Laborers - Nuclear, Radiation, Toxic and Hazardous Waste - Level C, Forklift Operators for Masonry, Form Setters, Green Concrete Cutting, Hand Operated Grouter and Grinder Machine Operator, Jack Hammers, Lead Paint

Abatement, Pavement Breakers, Paving Joint Machine, Pipe Layers - Laser Operators (Non-metallic), Plastic Pipe Fusion, Power Driven Georgia Buggy and Wheel Barrow, Power Post Hole Diggers, Precast Manhole Setters, Walk-behind Tampers, Walk-behind Trenchers, Sand Blasters, Concrete Chippers, Surface Grinders, Vibrator Operators, Wagon Drillers

GROUP 3: Air Track Driller (All Types), Asphalt Luteman and Rakers, Gunnite Nozzlemans, Gunnite Operators and Mixers, Grout Pump Operator, Powderman and Blaster, Side Rail Setters, Rail Paved Ditches, Screw Operators, Tunnel Laborers (Free Air), Water Blasters

GROUP 4: Caisson Workers (Free Air), Cement Finishers, Environmental Laborer - Nuclear, Radiation, Toxic and Hazardous Waste - Level A and B, miners and Drillers (Free Air), Tunnel Blasters, and Tunnel Mockers (Free Air), Directional and Horizontal Boring, Air Track Drillers (All Types), Powder Man and Blasters, Troxler and Concrete Tester if Laborer is Utilized

PAINTER

All Excluding Bridges.....	\$ 19.92	9.57
Bridges.....	\$ 23.92	10.07

PLUMBER.....\$ 22.52 7.80

POWER EQUIPMENT OPERATOR:

Group 1.....	\$ 29.95	14.40
Group 2.....	\$ 29.95	14.40
Group 3.....	\$ 27.26	14.40
Group 4.....	\$ 26.96	14.40

GROUP 1: Auto Patrol, Batch Plant, Bituminous Paver, Cable-Way, Clamshell, Concrete Mixer (21 cu ft or over), Concrete Pump, Crane, Crusher Plant, Derrick, Derrick Boat, Ditching and Trenching Machine, Dragline, Dredge Engineer, Elevator (regardless of ownership when used for hoisting of any building material), Elevating Grader and all types of Loaders, Hoe-type Machine, Hoisting Engine, Locomotive, LeTourneau or Carry-all Scoop, Bulldozer, Mechanic, Orangepeel Bucket, Piledriver, Power Blade, Roller (Bituminous), Roller (Earth), Roller (Rock), Scarifier, Shovel, Tractor Shovel, Truck Crane, Well Point, Winch Truck, Push Dozer, Grout Pump, High Lift, Fork Lift (regardless of lift height), all types of Boom Cats, Multiple Operator, Core Drill, Tow or Push Boat, A-Frame Winch Truck, Concrete Paver, Grade-All, Hoist, Hyster, Material Pump, Pumpcrete, Ross Carrier, Sheepfoot, Sideboom, Throttle-Valve Man, Rotary Drill, Power Generator, Mucking Machine, Rock Spreader attached to Equipment, Scoopmobile, KeCal Loader, Tower Cranes, (French, German and other types), Hydrocrane, Tugger, Backfiller Guries, Self-propelled Compactor, Self-Contained Hydraulic Percussion Drill

GROUP 2: All Air Compressors (200 cu ft/min or greater), Bituminous Mixer, Concrete Mixer (21 cu. ft. or over), Welding Machine, Form Grader, Tractor (50 hp and over), Bull Float, Finish Machine, Outboard Motor Boat, Brakeman, Mechanic Tender, Whirly Oiler, Tract-air, Road Widening Trencher, Articulating Trucks

GROUP 3: Greaser on Grease Facilities servicing Heavy Equipment

GROUP 4: Bituminous Distributor, Cement Gun, Conveyor, Mud Jack, Paving Joint Machine, Pump, Tamping Machine, Tractor (under 50 hp), Vibrator, Oiler, Air Compressor (under 200 cu ft per minute), Concrete Saw, Burlap and Curing Machine, Hydro Seeder, Power Form Handling Equipment, Deckhand Oiler, Hydraulic Post Driver

SHEET METAL WORKER.....\$ 20.40 7.80

TRUCK DRIVER

Driver (3 Tons and Over), Driver (Truck Mounted Rotary Drill).....\$ 23.74	14.50
Driver (3 Tons and Under), Tire Changer and Truck Mechanic Tender.....\$ 23.53	14.50
Driver (Semi-Trailer or Pole Trailer), Driver (Dump Truck, Tandem Axle), Driver of Distributor.....\$ 23.40	14.50
Driver on Mixer Trucks (All Types).....\$ 23.45	14.50
Driver on Pavement Breakers.\$ 23.55	14.50
Driver, Euclid and Other Heavy Earth Moving Equipment and Low Boy.....\$ 24.31	14.50
Driver, Winch Truck and A- Frame when used in Transporting Materials.....\$ 23.30	14.50
Greaser on Greasing Facilities.....\$ 24.40	14.50
Truck Mechanic.....\$ 23.50	14.50
Truck Tender and Warehouseman.....\$ 23.20	14.50

WELDERS - Receive rate prescribed for craft performing
operation to which welding is incidental.

=====
Note: Executive Order (EO) 13706, Establishing Paid Sick Leave
for Federal Contractors applies to all contracts subject to the
Davis-Bacon Act for which the contract is awarded (and any
solicitation was issued) on or after January 1, 2017. If this
contract is covered by the EO, the contractor must provide
employees with 1 hour of paid sick leave for every 30 hours
they work, up to 56 hours of paid sick leave each year.
Employees must be permitted to use paid sick leave for their
own illness, injury or other health-related needs, including
preventive care; to assist a family member (or person who is
like family to the employee) who is ill, injured, or has other
health-related needs, including preventive care; or for reasons
resulting from, or to assist a family member (or person who is
like family to the employee) who is a victim of, domestic
violence, sexual assault, or stalking. Additional information
on contractor requirements and worker protections under the EO
is available at
<https://www.dol.gov/agencies/whd/government-contracts>.

Unlisted classifications needed for work not included within
the scope of the classifications listed may be added after
award only as provided in the labor standards contract clauses
(29CFR 5.5 (a) (1) (ii)).

The body of each wage determination lists the classification
and wage rates that have been found to be prevailing for the
cited type(s) of construction in the area covered by the wage
determination. The classifications are listed in alphabetical

order of ""identifiers"" that indicate whether the particular rate is a union rate (current union negotiated rate for local), a survey rate (weighted average rate) or a union average rate (weighted union average rate).

Union Rate Identifiers

A four letter classification abbreviation identifier enclosed in dotted lines beginning with characters other than ""SU"" or ""UAVG"" denotes that the union classification and rate were prevailing for that classification in the survey. Example: PLUM0198-005 07/01/2014. PLUM is an abbreviation identifier of the union which prevailed in the survey for this classification, which in this example would be Plumbers. 0198 indicates the local union number or district council number where applicable, i.e., Plumbers Local 0198. The next number, 005 in the example, is an internal number used in processing the wage determination. 07/01/2014 is the effective date of the most current negotiated rate, which in this example is July 1, 2014.

Union prevailing wage rates are updated to reflect all rate changes in the collective bargaining agreement (CBA) governing this classification and rate.

Survey Rate Identifiers

Classifications listed under the ""SU"" identifier indicate that no one rate prevailed for this classification in the survey and the published rate is derived by computing a weighted average rate based on all the rates reported in the survey for that classification. As this weighted average rate includes all rates reported in the survey, it may include both union and non-union rates. Example: SULA2012-007 5/13/2014. SU indicates the rates are survey rates based on a weighted average calculation of rates and are not majority rates. LA indicates the State of Louisiana. 2012 is the year of survey on which these classifications and rates are based. The next number, 007 in the example, is an internal number used in producing the wage determination. 5/13/2014 indicates the survey completion date for the classifications and rates under that identifier.

Survey wage rates are not updated and remain in effect until a new survey is conducted.

Union Average Rate Identifiers

Classification(s) listed under the UAVG identifier indicate that no single majority rate prevailed for those classifications; however, 100% of the data reported for the classifications was union data. EXAMPLE: UAVG-OH-0010 08/29/2014. UAVG indicates that the rate is a weighted union average rate. OH indicates the state. The next number, 0010 in the example, is an internal number used in producing the wage determination. 08/29/2014 indicates the survey completion date for the classifications and rates under that identifier.

A UAVG rate will be updated once a year, usually in January of each year, to reflect a weighted average of the current negotiated/CBA rate of the union locals from which the rate is based.

WAGE DETERMINATION APPEALS PROCESS

1.) Has there been an initial decision in the matter? This can be:

- * an existing published wage determination
- * a survey underlying a wage determination
- * a Wage and Hour Division letter setting forth a position on a wage determination matter
- * a conformance (additional classification and rate) ruling

On survey related matters, initial contact, including requests for summaries of surveys, should be with the Wage and Hour National Office because National Office has responsibility for the Davis-Bacon survey program. If the response from this initial contact is not satisfactory, then the process described in 2.) and 3.) should be followed.

With regard to any other matter not yet ripe for the formal process described here, initial contact should be with the Branch of Construction Wage Determinations. Write to:

Branch of Construction Wage Determinations
 Wage and Hour Division
 U.S. Department of Labor
 200 Constitution Avenue, N.W.
 Washington, DC 20210

2.) If the answer to the question in 1.) is yes, then an interested party (those affected by the action) can request review and reconsideration from the Wage and Hour Administrator (See 29 CFR Part 1.8 and 29 CFR Part 7). Write to:

Wage and Hour Administrator
 U.S. Department of Labor
 200 Constitution Avenue, N.W.
 Washington, DC 20210

The request should be accompanied by a full statement of the interested party's position and by any information (wage payment data, project description, area practice material, etc.) that the requestor considers relevant to the issue.

3.) If the decision of the Administrator is not favorable, an interested party may appeal directly to the Administrative Review Board (formerly the Wage Appeals Board). Write to:

Administrative Review Board
 U.S. Department of Labor
 200 Constitution Avenue, N.W.
 Washington, DC 20210

4.) All decisions by the Administrative Review Board are final.

=====

END OF GENERAL DECISIO"

Fringe benefit amounts are applicable for all hours worked except when otherwise noted.

No laborer, workman or mechanic shall be paid at a rate less than that of a Journeyman except those classified as bona fide apprentices.

Apprentices or trainees shall be permitted to work as such subject to Administrative Regulations adopted by the Commissioner of Workplace Standards. Copies of these regulations will be furnished upon request from any interested person.

Before using apprentices on the job the contractor shall present to the Contracting Officer written evidence of registration of such employees in a program of a State apprenticeship and training agency approved and recognized by the U. S. Bureau of Apprenticeship and Training. In the absence of such a State agency, the contractor shall submit evidence of approval and registration by the U. S. Bureau of Apprenticeship and Training.

The contractor shall submit to the Contracting Officer, written evidence of the established apprenticeship-journeyman ratios and wage rates in the project area, which will be the basis for establishing such ratios and rates for the project under the applicable contract provisions.

TO: EMPLOYERS/EMPLOYEES

PREVAILING WAGE SCHEDULE:

The wages indicated on this wage schedule are the least permitted to be paid for the occupations indicated. When an employee works in more than one classification, the employer must record the number of hours worked in each classification at the prescribed hourly base rate.

OVERTIME:

Overtime is to be paid to an employee at a rate not less than one and one-half times the basic rate of pay for all hours worked in excess of forty (40) hours in such workweek. Wage violations or questions should be directed to the designated Engineer or the undersigned.

Director
Division of Construction Procurement
Frankfort, Kentucky 40622
502-564-3500

**NOTICE OF REQUIREMENT FOR AFFIRMATIVE ACTION
TO ENSURE EQUAL EMPLOYMENT OPPORTUNITY
(Executive Order 11246)**

1. The Offeror's or Bidder's attention is called to the "Equal Opportunity Clause" and the "Standard Federal Equal Employment Specifications" set forth herein.
2. The goals and timetables for minority and female participation, expressed in percentage terms for the Contractor's aggregate work force in each trade on all construction work in the covered area, are as follows:

GOALS FOR MINORITY PARTICIPATION IN EACH TRADE	GOALS FOR FEMALE PARTICIPATION IN EACH TRADE
4.5%	6.9%

These goals are applicable to all the Contractor's construction work (whether or not it is Federal or federally-assisted) performed in the covered area. If the contractor performs construction work in a geographical area located outside of the covered area, it shall apply the goals established for such geographical area where the work is actually performed. With regard to this second area, the contractor also is subject to the goals for both its federally involved and non-federally involved construction.

The Contractor's compliance with the Executive Order and the regulations in CFR Part 60-4 shall be based on its implementation of the Equal Opportunity Clause, specific affirmative action obligations required by the specifications set forth in 41 CFR 60-4, 3(a), and its efforts to meet the goals. The hours of minority and female employment and training must be substantially uniform throughout the length of the contract, and in each trade, and the contractor shall make a good faith effort to employ minorities and women evenly on each of its projects. The transfer of minority or female employees or trainees from Contractor to Contractor or from project to project for the sole purpose of meeting the Contractor's goals shall be a violation of the contract, the Executive Order and the regulations in 41 CFR Part 60-4. Compliance with the goals will be measured against the total work hours performed.

3. The Contractor shall provide written notification to the Director of the Office of Federal Contract Compliance Programs within ten (10) working days of award of any construction subcontract in excess of \$10,000.00 at any tier for construction work under the contract resulting from this solicitation. The notification shall list the name, address and telephone number of the subcontractor; employer identification number of the subcontractor; estimated dollar amount of the subcontract; estimated starting and completion dates of the subcontract; and the geographical area in which the subcontract is to be performed. The notification shall be mailed to:

**Evelyn Teague, Regional Director
Office of Federal Contract Compliance Programs
61 Forsyth Street, SW, Suite 7B75
Atlanta, Georgia 30303-8609**

4. As used in this Notice, and in the contract resulting from this solicitation, the "**covered area**" is Laurel County.

PART IV
INSURANCE

Refer to
Kentucky Standard Specifications for Road and Bridge Construction,
current edition

PART V
BID ITEMS

PROPOSAL BID ITEMS

221352

Page 1 of 9

Report Date 9/21/22

Section: 0001 - PAVING - ALT 1 - ASPHALT

LINE	BID CODE	ALT	DESCRIPTION	QUANTITY	UNIT	UNIT PRIC	FP	AMOUNT
0010	00003		CRUSHED STONE BASE	37,877.00	TON		\$	
0020	00100		ASPHALT SEAL AGGREGATE	476.00	TON		\$	
0030	00103		ASPHALT SEAL COAT	58.00	TON		\$	
0040	00190		LEVELING & WEDGING PG64-22	600.00	TON		\$	
0050	00214		CL3 ASPH BASE 1.00D PG64-22	5,329.00	TON		\$	
0060	00216		CL3 ASPH BASE 1.00D PG76-22	4,186.00	TON		\$	
0070	00223		CL3 ASPH BASE 0.75D PG64-22	5,027.00	TON		\$	
0080	00225		CL3 ASPH BASE 0.75D PG76-22	4,875.00	TON		\$	
0090	00336		CL3 ASPH SURF 0.38A PG76-22	5,299.00	TON		\$	
0100	00339		CL3 ASPH SURF 0.38D PG64-22	14,799.00	TON		\$	
0110	00356		ASPHALT MATERIAL FOR TACK	148.00	TON		\$	
0120	02064		PCC BASE-9 IN	3,303.00	SQYD		\$	
0130	02069		JPC PAVEMENT-10 IN	11,115.00	SQYD		\$	
0140	02084		JPC PAVEMENT-8 IN	23,090.00	SQYD		\$	
0150	10203ND		PAVEMENT ADJUSTMENT (ASPHALT)	1.00	LS	\$401,420.0	\$	\$401,420.00
0160	24904EC		CL3 ASPH BASE CK PG64-22	22,647.00	TON		\$	

Section: 0002 - PAVING - ALT 2 - CONCRETE

LINE	BID CODE	ALT	DESCRIPTION	QUANTITY	UNIT	UNIT PRIC	FP	AMOUNT
0170	00003		CRUSHED STONE BASE	37,865.00	TON		\$	
0180	00100		ASPHALT SEAL AGGREGATE	476.00	TON		\$	
0190	00103		ASPHALT SEAL COAT	58.00	TON		\$	
0200	00190		LEVELING & WEDGING PG64-22	600.00	TON		\$	
0210	00214		CL3 ASPH BASE 1.00D PG64-22	5,117.00	TON		\$	
0220	00216		CL3 ASPH BASE 1.00D PG76-22	4,037.00	TON		\$	
0230	00223		CL3 ASPH BASE 0.75D PG64-22	5,100.00	TON		\$	
0240	00336		CL3 ASPH SURF 0.38A PG76-22	1,989.00	TON		\$	
0250	00339		CL3 ASPH SURF 0.38D PG64-22	14,965.00	TON		\$	
0260	00356		ASPHALT MATERIAL FOR TACK	100.00	TON		\$	
0270	02064		PCC BASE-9 IN	8,696.00	SQYD		\$	
0280	02069		JPC PAVEMENT-10 IN	12,011.00	SQYD		\$	
0290	02084		JPC PAVEMENT-8 IN	60,306.00	SQYD		\$	
0300	10203ND		PAVEMENT ADJUSTMENT (CONCRETE)	1.00	LS	\$203,944.0	\$	\$203,944.00
0310	24904EC		CL3 ASPH BASE CK PG64-22	10,968.00	TON		\$	

Section: 0003 - ROADWAY

LINE	BID CODE	ALT	DESCRIPTION	QUANTITY	UNIT	UNIT PRIC	FP	AMOUNT
0320	00020		TRAFFIC BOUND BASE	1,000.00	TON		\$	
0330	00078		CRUSHED AGGREGATE SIZE NO 2	12,815.00	TON		\$	
0340	01015		INSPECT & CERTIFY EDGE DRAIN SYSTEM	1.00	LS		\$	
0350	01584		CAP DROP BOX INLET	2.00	EACH		\$	

PROPOSAL BID ITEMS

221352

Page 2 of 9

Report Date 9/21/22

LINE	BID CODE	ALT	DESCRIPTION	QUANTITY	UNIT	UNIT PRIC	FP	AMOUNT
0360	01691		FLUME INLET TYPE 2	4.00	EACH		\$	
0370	01810		STANDARD CURB AND GUTTER	3,626.00	LF		\$	
0380	01825		ISLAND CURB AND GUTTER	2,079.00	LF		\$	
0390	01830		STANDARD INTEGRAL CURB	2,346.00	LF		\$	
0400	01875		STANDARD HEADER CURB	1,459.00	LF		\$	
0410	01890		ISLAND HEADER CURB TYPE 1	561.00	LF		\$	
0420	01891		ISLAND HEADER CURB TYPE 2	100.00	LF		\$	
0430	01982		DELINEATOR FOR GUARDRAIL MONO DIRECTIONAL WHITE	65.00	EACH		\$	
0440	01983		DELINEATOR FOR GUARDRAIL MONO DIRECTIONAL YELLOW	16.00	EACH		\$	
0450	01984		DELINEATOR FOR BARRIER - WHITE	8.00	EACH		\$	
0460	01985		DELINEATOR FOR BARRIER - YELLOW	8.00	EACH		\$	
0470	01987		DELINEATOR FOR GUARDRAIL BI DIRECTIONAL WHITE	41.00	EACH		\$	
0480	02014		BARRICADE-TYPE III	20.00	EACH		\$	
0490	02091		REMOVE PAVEMENT	2,180.00	SQYD		\$	
0500	02101		CEM CONC ENT PAVEMENT-8 IN	3,549.00	SQYD		\$	
0510	02155		PAVED DITCH TYPE 1 MOD	11.00	SQYD		\$	
0520	02159		TEMP DITCH	4,750.00	LF		\$	
0530	02160		CLEAN TEMP DITCH	2,375.00	LF		\$	
0540	02200		ROADWAY EXCAVATION	80,225.00	CUYD		\$	
0550	02203		STRUCTURE EXCAV-UNCLASSIFIED	462.00	CUYD		\$	
0560	02204		SPECIAL EXCAVATION	300.00	CUYD		\$	
0570	02242		WATER	100.00	MGAL		\$	
0580	02351		GUARDRAIL-STEEL W BEAM-S FACE	6,901.00	LF		\$	
0590	02352		GUARDRAIL-STEEL W BEAM-D FACE	275.00	LF		\$	
0600	02360		GUARDRAIL TERMINAL SECTION NO 1	12.00	EACH		\$	
0610	02363		GUARDRAIL CONNECTOR TO BRIDGE END TY A	11.00	EACH		\$	
0620	02365		CRASH CUSHION TYPE IX-A	2.00	EACH		\$	
0630	02367		GUARDRAIL END TREATMENT TYPE 1	14.00	EACH		\$	
0640	02369		GUARDRAIL END TREATMENT TYPE 2A	4.00	EACH		\$	
0650	02371		GUARDRAIL END TREATMENT TYPE 7	1.00	EACH		\$	
0660	02381		REMOVE GUARDRAIL	6,894.50	LF		\$	
0670	02382		GUARDRAIL CONNECT-SHLD BRIDGE PIER TY A	2.00	EACH		\$	
0680	02384		GUARDRAIL CONNECT SHLD BRIDGE PIER TY A1	1.00	EACH		\$	
0690	02387		GUARDRAIL CONNECTOR TO BRIDGE END TY A-1	1.00	EACH		\$	
0700	02397		TEMP GUARDRAIL	300.00	LF		\$	
0710	02429		RIGHT-OF-WAY MONUMENT TYPE 1	37.00	EACH		\$	
0720	02430		RIGHT-OF-WAY MONUMENT TYPE 1A	5.00	EACH		\$	
0730	02431		WITNESS R/W MONUMENT TYPE 2	1.00	EACH		\$	
0740	02432		WITNESS POST	5.00	EACH		\$	
0750	02483		CHANNEL LINING CLASS II	3,044.00	TON		\$	
0760	02484		CHANNEL LINING CLASS III	3,108.00	TON		\$	
0770	02545		CLEARING AND GRUBBING (21 ACRES)	1.00	LS		\$	
0780	02555		CONCRETE-CLASS B	294.20	CUYD		\$	
0790	02562		TEMPORARY SIGNS	1,200.00	SQFT		\$	

PROPOSAL BID ITEMS

221352

Page 3 of 9

Report Date 9/21/22

LINE	BID CODE	ALT	DESCRIPTION	QUANTITY	UNIT	UNIT PRIC	FP	AMOUNT
0800	02587		HOOK BOLT WITH EXPAN ANCHOR	1,900.00	EACH		\$	
0810	02603		FABRIC-GEOTEXTILE CLASS 2	24,205.00	SQYD		\$	
0820	02611		HANDRAIL-TYPE A-1	430.00	LF		\$	
0830	02650		MAINTAIN & CONTROL TRAFFIC	1.00	LS		\$	
0840	02671		PORTABLE CHANGEABLE MESSAGE SIGN	6.00	EACH		\$	
0850	02676		MOBILIZATION FOR MILL & TEXT	1.00	LS		\$	
0860	02677		ASPHALT PAVE MILLING & TEXTURING	1,850.00	TON		\$	
0870	02690		SAFELoading	69.00	CUYD		\$	
0880	02701		TEMP SILT FENCE	4,750.00	LF		\$	
0890	02703		SILT TRAP TYPE A	20.00	EACH		\$	
0900	02704		SILT TRAP TYPE B	20.00	EACH		\$	
0910	02705		SILT TRAP TYPE C	20.00	EACH		\$	
0920	02706		CLEAN SILT TRAP TYPE A	20.00	EACH		\$	
0930	02707		CLEAN SILT TRAP TYPE B	20.00	EACH		\$	
0940	02708		CLEAN SILT TRAP TYPE C	20.00	EACH		\$	
0950	02720		SIDEWALK-4 IN CONCRETE	1,541.00	SQYD		\$	
0960	02726		STAKING	1.00	LS		\$	
0970	02731		REMOVE STRUCTURE	1.00	LS		\$	
0980	02775		ARROW PANEL	2.00	EACH		\$	
0990	02998		MASONRY COATING	534.00	SQYD		\$	
1000	03225		TUBULAR MARKERS	80.00	EACH		\$	
1010	05950		EROSION CONTROL BLANKET	11,847.00	SQYD		\$	
1020	05952		TEMP MULCH	61,491.00	SQYD		\$	
1030	05953		TEMP SEEDING AND PROTECTION	46,118.00	SQYD		\$	
1040	05963		INITIAL FERTILIZER	5.30	TON		\$	
1050	05964		MAINTENANCE FERTILIZER	3.20	TON		\$	
1060	05985		SEEDING AND PROTECTION	85,651.00	SQYD		\$	
1070	05990		SODDING	6,536.00	SQYD		\$	
1080	05992		AGRICULTURAL LIMESTONE	57.20	TON		\$	
1090	06401		FLEXIBLE DELINEATOR POST-M/W	126.00	EACH		\$	
1100	06510		PAVE STRIPING-TEMP PAINT-4 IN	44,850.00	LF		\$	
1110	06511		PAVE STRIPING-TEMP PAINT-6 IN	112,750.00	LF		\$	
1120	06549		PAVE STRIPING-TEMP REM TAPE-B	250.00	LF		\$	
1130	06550		PAVE STRIPING-TEMP REM TAPE-W	15,040.00	LF		\$	
1140	06551		PAVE STRIPING-TEMP REM TAPE-Y	10,560.00	LF		\$	
1150	06585		PAVEMENT MARKER TY IVA-MW TEMP	880.00	EACH		\$	
1160	06600		REMOVE PAVEMENT MARKER TYPE V	720.00	EACH		\$	
1170	06610		INLAID PAVEMENT MARKER-MW	314.00	EACH		\$	
1180	06612		INLAID PAVEMENT MARKER-BY	105.00	EACH		\$	
1190	06613		INLAID PAVEMENT MARKER-B W/R	258.00	EACH		\$	
1200	06614		INLAID PAVEMENT MARKER-B Y/R	9.00	EACH		\$	
1210	08100		CONCRETE-CLASS A	59.10	CUYD		\$	
1220	08150		STEEL REINFORCEMENT	1,456.00	LB		\$	
1230	08900		CRASH CUSHION TY VI CLASS B TL2	2.00	EACH		\$	
1240	20191ED		OBJECT MARKER TY 3	16.00	EACH		\$	
1250	21289ED		LONGITUDINAL EDGE KEY	1,910.00	LF		\$	
1260	23158ES505		DETECTABLE WARNINGS	485.00	SQFT		\$	
1270	24540		R/W MONUMENT TYPE 3	14.00	EACH		\$	
1280	24541		R/W MONUMENT TYPE 3A	13.00	EACH		\$	
1290	24651ED		CONCRETE ISLAND	1,347.00	SQYD		\$	

PROPOSAL BID ITEMS

221352

Page 4 of 9

Report Date 9/21/22

LINE	BID CODE	ALT	DESCRIPTION	QUANTITY	UNIT	UNIT PRIC	FP	AMOUNT
1300	24814EC		PIPELINE INSPECTION	4,940.00	LF		\$	
1310	24889EC		PAVE MARKING-THERMO U-TURN	1.00	EACH		\$	

Section: 0004 - ROADWAY - ALT 1 - ASPHALT

LINE	BID CODE	ALT	DESCRIPTION	QUANTITY	UNIT	UNIT PRIC	FP	AMOUNT
1320	02107		BREAKING AND SEATING PAVEMENT	32,013.00	SQYD		\$	
1330	02655		CROSSOVER	1.00	LS		\$	
1340	06542		PAVE STRIPING-THERMO-6 IN W	24,363.00	LF		\$	
1350	06543		PAVE STRIPING-THERMO-6 IN Y	10,932.00	LF		\$	
1360	06546		PAVE STRIPING-THERMO-12 IN W	1,056.00	LF		\$	
1370	06556		PAVE STRIPING-DUR TY 1-6 IN W	10,869.00	LF		\$	
1380	06557		PAVE STRIPING-DUR TY 1-6 IN Y	5,514.00	LF		\$	
1390	06560		PAVE STRIPING-DUR TY 1-12 IN W	85.00	LF		\$	
1400	06568		PAVE MARKING-THERMO STOP BAR-24IN	846.00	LF		\$	
1410	06569		PAVE MARKING-THERMO CROSS-HATCH	1,600.00	SQFT		\$	
1420	06574		PAVE MARKING-THERMO CURV ARROW	95.00	EACH		\$	
1430	06575		PAVE MARKING-THERMO COMB ARROW	27.00	EACH		\$	
1440	06576		PAVE MARKING-THERMO ONLY	7.00	EACH		\$	
1450	10020NS		FUEL ADJUSTMENT	140,527.00	DOLL	\$1.00	\$	\$140,527.00
1460	10030NS		ASPHALT ADJUSTMENT	244,948.00	DOLL	\$1.00	\$	\$244,948.00
1470	23253ES717		PAVE MARK TY 1 TAPE CROSS-HATCH	1,380.00	SQFT		\$	
1480	23256ES717		PAVE MARK TY 1 TAPE -ONLY	7.00	EACH		\$	
1490	23265ES717		PAVE MARK TY 1 TAPE STOP BAR-24 IN	389.00	LF		\$	
1500	23269ES717		PAVE MARK TY 1 TAPE-COMBO ARROW	20.00	EACH		\$	
1510	23270ES717		PAVE MARK TY 1 TAPE-CURV ARROW	56.00	EACH		\$	
1520	23791EC		PAVE STRIPING-CHEVRON MARKINGS	2,200.00	SQFT		\$	
1530	24401EC		DURABLE WATERBORNE MARKING-4 IN W	14,304.00	LF		\$	
1540	24402EC		DURABLE WATERBORNE MARKING-4 IN Y	13,338.00	LF		\$	
1550	24679ED		PAVE MARK THERMO CHEVRON	660.00	SQFT		\$	

Section: 0005 - ROADWAY - ALT 2 - CONCRETE

LINE	BID CODE	ALT	DESCRIPTION	QUANTITY	UNIT	UNIT PRIC	FP	AMOUNT
1560	06542		PAVE STRIPING-THERMO-6 IN W	8,041.00	LF		\$	
1570	06543		PAVE STRIPING-THERMO-6 IN Y	3,228.00	LF		\$	
1580	06546		PAVE STRIPING-THERMO-12 IN W	780.00	LF		\$	
1590	06556		PAVE STRIPING-DUR TY 1-6 IN W	26,973.00	LF		\$	
1600	06557		PAVE STRIPING-DUR TY 1-6 IN Y	13,217.00	LF		\$	
1610	06560		PAVE STRIPING-DUR TY 1-12 IN W	362.00	LF		\$	
1620	06568		PAVE MARKING-THERMO STOP BAR-24IN	459.00	LF		\$	
1630	06569		PAVE MARKING-THERMO CROSS-HATCH	1,420.00	SQFT		\$	
1640	06574		PAVE MARKING-THERMO CURV ARROW	137.00	EACH		\$	
1650	06575		PAVE MARKING-THERMO COMB ARROW	11.00	EACH		\$	
1660	06576		PAVE MARKING-THERMO ONLY	10.00	EACH		\$	
1670	10020NS		FUEL ADJUSTMENT	122,051.00	DOLL	\$1.00	\$	\$122,051.00
1680	10030NS		ASPHALT ADJUSTMENT	166,791.00	DOLL	\$1.00	\$	\$166,791.00

PROPOSAL BID ITEMS

221352

Page 5 of 9

Report Date 9/21/22

LINE	BID CODE	ALT	DESCRIPTION	QUANTITY	UNIT	UNIT PRIC	FP	AMOUNT
1690	23253ES717		PAVE MARK TY 1 TAPE CROSS-HATCH	1,380.00	SQFT		\$	
1700	23256ES717		PAVE MARK TY 1 TAPE -ONLY	5.00	EACH		\$	
1710	23265ES717		PAVE MARK TY 1 TAPE STOP BAR-24 IN	776.00	LF		\$	
1720	23269ES717		PAVE MARK TY 1 TAPE-COMBO ARROW	7.00	EACH		\$	
1730	23270ES717		PAVE MARK TY 1 TAPE-CURV ARROW	8.00	EACH		\$	
1740	23791EC		PAVE STRIPING-CHEVRON MARKINGS	2,200.00	SQFT		\$	
1750	24401EC		DURABLE WATERBORNE MARKING-4 IN W	14,304.00	LF		\$	
1760	24402EC		DURABLE WATERBORNE MARKING-4 IN Y	13,340.00	LF		\$	
1770	24679ED		PAVE MARK THERMO CHEVRON	580.00	SQFT		\$	

Section: 0006 - DRAINAGE

LINE	BID CODE	ALT	DESCRIPTION	QUANTITY	UNIT	UNIT PRIC	FP	AMOUNT
1780	00078		CRUSHED AGGREGATE SIZE NO 2	36.00	TON		\$	
1790	00440		ENTRANCE PIPE-15 IN	261.00	LF		\$	
1800	00441		ENTRANCE PIPE-18 IN	117.00	LF		\$	
1810	00443		ENTRANCE PIPE-24 IN	85.00	LF		\$	
1820	00461		CULVERT PIPE-15 IN	95.00	LF		\$	
1830	00462		CULVERT PIPE-18 IN	1,843.00	LF		\$	
1840	00464		CULVERT PIPE-24 IN	167.00	LF		\$	
1850	00466		CULVERT PIPE-30 IN	186.00	LF		\$	
1860	00468		CULVERT PIPE-36 IN	54.00	LF		\$	
1870	00474		CULVERT PIPE-72 IN	80.00	LF		\$	
1880	00521		STORM SEWER PIPE-15 IN	684.00	LF		\$	
1890	00522		STORM SEWER PIPE-18 IN	1,652.00	LF		\$	
1900	00524		STORM SEWER PIPE-24 IN	275.00	LF		\$	
1910	00526		STORM SEWER PIPE-30 IN	134.00	LF		\$	
1920	00528		STORM SEWER PIPE-36 IN	60.00	LF		\$	
1930	00529		STORM SEWER PIPE-42 IN	205.00	LF		\$	
1940	01000		PERFORATED PIPE-4 IN	19,344.00	LF		\$	
1950	01001		PERFORATED PIPE-6 IN	3,344.00	LF		\$	
1960	01010		NON-PERFORATED PIPE-4 IN	1,303.00	LF		\$	
1970	01011		NON-PERFORATED PIPE-6 IN	54.00	LF		\$	
1980	01020		PERF PIPE HEADWALL TY 1-4 IN	9.00	EACH		\$	
1990	01028		PERF PIPE HEADWALL TY 3-4 IN	22.00	EACH		\$	
2000	01029		PERF PIPE HEADWALL TY 3-6 IN	3.00	EACH		\$	
2010	01032		PERF PIPE HEADWALL TY 4-4 IN	7.00	EACH		\$	
2020	01202		PIPE CULVERT HEADWALL-15 IN	2.00	EACH		\$	
2030	01204		PIPE CULVERT HEADWALL-18 IN	16.00	EACH		\$	
2040	01208		PIPE CULVERT HEADWALL-24 IN	1.00	EACH		\$	
2050	01210		PIPE CULVERT HEADWALL-30 IN	2.00	EACH		\$	
2060	01212		PIPE CULVERT HEADWALL-36 IN	2.00	EACH		\$	
2070	01214		PIPE CULVERT HEADWALL-42 IN	1.00	EACH		\$	
2080	01381		METAL END SECTION TY 2-18 IN	1.00	EACH		\$	
2090	01433		SLOPED BOX OUTLET TYPE 1-18 IN	10.00	EACH		\$	
2100	01434		SLOPED BOX OUTLET TYPE 1-24 IN	1.00	EACH		\$	
2110	01450		S & F BOX INLET-OUTLET-18 IN	14.00	EACH		\$	
2120	01451		S & F BOX INLET-OUTLET-24 IN	3.00	EACH		\$	

PROPOSAL BID ITEMS

221352

Page 6 of 9

Report Date 9/21/22

LINE	BID CODE	ALT	DESCRIPTION	QUANTITY	UNIT	UNIT PRIC	FP	AMOUNT
2130	01452		S & F BOX INLET-OUTLET-30 IN	2.00	EACH		\$	
2140	01453		S & F BOX INLET-OUTLET-36 IN	1.00	EACH		\$	
2150	01456		CURB BOX INLET TYPE A	3.00	EACH		\$	
2160	01480		CURB BOX INLET TYPE B	16.00	EACH		\$	
2170	01487		CURB BOX INLET TYPE F	1.00	EACH		\$	
2180	01490		DROP BOX INLET TYPE 1	7.00	EACH		\$	
2190	01505		DROP BOX INLET TYPE 5B	6.00	EACH		\$	
2200	01517		DROP BOX INLET TYPE 5F	5.00	EACH		\$	
2210	01538		DROP BOX INLET TYPE 7	3.00	EACH		\$	
2220	01544		DROP BOX INLET TYPE 11	17.00	EACH		\$	
2230	01568		DROP BOX INLET TYPE 13S	1.00	EACH		\$	
2240	01650		JUNCTION BOX	13.00	EACH		\$	
2250	01653		JUNCTION BOX-SPECIAL	1.00	EACH		\$	
2260	01740		CORED HOLE DRAINAGE BOX CON-4 IN	40.00	EACH		\$	
2270	01741		CORED HOLE DRAINAGE BOX CON-6 IN	2.00	EACH		\$	
2280	01756		MANHOLE TYPE A	1.00	EACH		\$	
2290	01761		MANHOLE TYPE B	2.00	EACH		\$	
2300	01767		MANHOLE TYPE C	1.00	EACH		\$	
2310	02607		FABRIC-GEOTEXTILE CLASS 2 FOR PIPE	4,327.00	SQYD	\$2.00	\$	\$8,654.00
2320	08100		CONCRETE-CLASS A	39.40	CUYD		\$	
2330	23610NC		CORED HOLE DRAINAGE BOX CON	1.00	EACH		\$	
2340	23952EC		DRAINAGE JUNCTION BOX TY B	2.00	EACH		\$	
2350	24025EC		PIPE CULVERT HEADWALL-72 IN	2.00	EACH		\$	

Section: 0007 - BRIDGE - #27653 RCBC

LINE	BID CODE	ALT	DESCRIPTION	QUANTITY	UNIT	UNIT PRIC	FP	AMOUNT
2360	02223		GRANULAR EMBANKMENT	10.00	CUYD		\$	
2370	08002		STRUCTURE EXCAV-SOLID ROCK	181.00	CUYD		\$	
2380	08003		FOUNDATION PREPARATION	1.00	LS		\$	
2390	08100		CONCRETE-CLASS A	73.30	CUYD		\$	
2400	08150		STEEL REINFORCEMENT	6,526.00	LB		\$	

Section: 0008 - BRIDGE - #27652 KY1223 OVER HORSE CREEK

LINE	BID CODE	ALT	DESCRIPTION	QUANTITY	UNIT	UNIT PRIC	FP	AMOUNT
2410	02231		STRUCTURE GRANULAR BACKFILL	67.00	CUYD		\$	
2420	02998		MASONRY COATING	183.00	SQYD		\$	
2430	03299		ARMORED EDGE FOR CONCRETE	52.00	LF		\$	
2440	08001		STRUCTURE EXCAVATION-COMMON	462.00	CUYD		\$	
2450	08002		STRUCTURE EXCAV-SOLID ROCK	38.00	CUYD		\$	
2460	08019		CYCLOPEAN STONE RIP RAP	110.00	TON		\$	
2470	08100		CONCRETE-CLASS A	151.00	CUYD		\$	
2480	08104		CONCRETE-CLASS AA	27.90	CUYD		\$	
2490	08150		STEEL REINFORCEMENT	14,250.00	LB		\$	
2500	08151		STEEL REINFORCEMENT-EPOXY COATED	6,250.00	LB		\$	
2510	08668		PRECAST PC BOX BEAM SB17	94.50	LF		\$	

PROPOSAL BID ITEMS

221352

Page 7 of 9

Report Date 9/21/22

LINE	BID CODE	ALT	DESCRIPTION	QUANTITY	UNIT	UNIT PRIC	FP	AMOUNT
2520	21532ED		RAIL SYSTEM TYPE III	63.00	LF		\$	

Section: 0009 - SEWER - CORBIN

LINE	BID CODE	ALT	DESCRIPTION	QUANTITY	UNIT	UNIT PRIC	FP	AMOUNT
2530	15000		S BYPASS PUMPING	21.00	EACH		\$	
2540	15014		S ENCASMENT STEEL BORED RANGE 1	60.00	LF		\$	
2550	15016		S ENCASMENT STEEL BORED RANGE 3	60.00	LF		\$	
2560	15017		S ENCASMENT STEEL BORED RANGE 4	90.00	LF		\$	
2570	15018		S ENCASMENT STEEL BORED RANGE 5	75.00	LF		\$	
2580	15023		S ENCASMENT STEEL OPEN CUT RANGE 4	175.00	LF		\$	
2590	15024		S ENCASMENT STEEL OPEN CUT RANGE 5	180.00	LF		\$	
2600	15036		S FORCE MAIN DUCTILE IRON 12 INCH	675.00	LF		\$	
2610	15057		S FORCE MAIN PVC 02 INCH	600.00	LF		\$	
2620	15058		S FORCE MAIN PVC 03 INCH	45.00	LF		\$	
2630	15060		S FORCE MAIN PVC 06 INCH	605.00	LF		\$	
2640	15071		S FORCE MAIN TIE-IN 02 INCH	1.00	EACH		\$	
2650	15072		S FORCE MAIN TIE-IN 03 INCH	1.00	EACH		\$	
2660	15074		S FORCE MAIN TIE-IN 06 INCH	1.00	EACH		\$	
2670	15077		S FORCE MAIN TIE-IN 12 INCH	3.00	EACH		\$	
2680	15086		S LATERAL CLEANOUT	5.00	EACH		\$	
2690	15088		S LATERAL LONG SIDE 06 INCH	5.00	EACH		\$	
2700	15092		S MANHOLE	35.00	EACH		\$	
2710	15093		S MANHOLE ABANDON/REMOVE	17.00	EACH		\$	
2720	15095		S MANHOLE CASTING STANDARD	35.00	EACH		\$	
2730	15106		S PIPE DUCTILE IRON 12 INCH	551.00	LF		\$	
2740	15112		S PIPE PVC 08 INCH	2,454.00	LF		\$	
2750	15113		S PIPE PVC 10 INCH	1,271.00	LF		\$	
2760	15114		S PIPE PVC 12 INCH	325.00	LF		\$	
2770	15120		S SPECIAL ITEM - S CAP EXISTING MAIN	4.00	EACH		\$	

Section: 0010 - SIGNALIZATION

LINE	BID CODE	ALT	DESCRIPTION	QUANTITY	UNIT	UNIT PRIC	FP	AMOUNT
2780	04820		TRENCHING AND BACKFILLING	370.00	LF		\$	
2790	04845		CABLE-NO. 14/7C	8,905.00	LF		\$	
2800	04886		MESSENGER-15400 LB	3,435.00	LF		\$	
2810	04932		INSTALL STEEL STRAIN POLE	28.00	EACH		\$	
2820	04953		TEMP RELOCATION OF SIGNAL HEAD	76.00	EACH		\$	
2830	06472		INSTALL SPAN MOUNTED SIGN	10.00	EACH		\$	
2840	20093NS835		INSTALL PEDESTRIAN HEAD-LED	2.00	EACH		\$	
2850	20188NS835		INSTALL LED SIGNAL-3 SECTION	65.00	EACH		\$	
2860	20266ES835		INSTALL LED SIGNAL- 4 SECTION	13.00	EACH		\$	
2870	20390NS835		INSTALL COORDINATING UNIT	7.00	EACH		\$	
2880	21743NN		INSTALL PEDESTRIAN DETECTOR	2.00	EACH		\$	
2890	23157EN		TRAFFIC SIGNAL POLE BASE	118.30	CUYD		\$	

PROPOSAL BID ITEMS

221352

Page 8 of 9

Report Date 9/21/22

LINE	BID CODE	ALT	DESCRIPTION	QUANTITY	UNIT	UNIT PRIC	FP	AMOUNT
2900	23235EC		INSTALL PEDESTAL POST	1.00	EACH		\$	
2910	24900EC		PVC CONDUIT-1 1/4 IN-SCHEDULE 80	20.00	LF		\$	
2920	24901EC		PVC CONDUIT-2 IN-SCHEDULE 80	560.00	LF		\$	
2930	24908EC		INSTALL SIGNAL CONTROLLER-TY ATC	7.00	EACH		\$	
2940	24955ED		REMOVE SIGNAL EQUIPMENT	7.00	EACH		\$	
2950	26119EC		INSTALL RADAR PRESENCE DETECTOR TYPE A	26.00	EACH		\$	

Section: 0011 - WATERLINE - BARBOURVILLE

LINE	BID CODE	ALT	DESCRIPTION	QUANTITY	UNIT	UNIT PRIC	FP	AMOUNT
2960	14000		W AIR RELEASE VALVE 1 INCH	1.00	EACH		\$	
2970	14003		W CAP EXISTING MAIN	4.00	EACH		\$	
2980	14011		W ENCASEMENT STEEL BORED RANGE 6	690.00	LF		\$	
2990	14017		W ENCASEMENT STEEL OPEN CUT RANGE 6	390.00	LF		\$	
3000	14055		W PIPE DUCTILE IRON SPECIAL	4,736.00	LF		\$	
3010	14101		W TIE-IN SPECIAL	4.00	EACH		\$	
3020	14124		W VALVE SPECIAL	5.00	EACH		\$	
3030	14126		W ENCASEMENT SPECIAL -3' WIDE X 6" THICK CONCRETE CAP	25.00	LF		\$	

Section: 0012 - WATERLINE - CORBIN

LINE	BID CODE	ALT	DESCRIPTION	QUANTITY	UNIT	UNIT PRIC	FP	AMOUNT
3040	14003		W CAP EXISTING MAIN	6.00	EACH		\$	
3050	14009		W ENCASEMENT STEEL BORED RANGE 4	100.00	LF		\$	
3060	14010		W ENCASEMENT STEEL BORED RANGE 5	190.00	LF		\$	
3070	14019		W FIRE HYDRANT ASSEMBLY	1.00	EACH		\$	
3080	14037		W PIPE DUCTILE IRON 08 INCH	585.00	LF		\$	
3090	14039		W PIPE DUCTILE IRON 12 INCH	430.00	LF		\$	
3100	14089		W TAPPING SLEEVE AND VALVE SIZE 1	3.00	EACH		\$	
3110	14097		W TIE-IN 12 INCH	2.00	EACH		\$	
3120	14108		W VALVE 12 INCH	2.00	EACH		\$	
3130	14636		W SPECIAL ITEM INST (12 INCH LINE STOP)	1.00	EACH		\$	
3140	14636		W SPECIAL ITEM INST (8 INCH LINE STOP)	3.00	EACH		\$	

Section: 0013 - WATERLINE - LAUREL CO WATER DISTRICT #2

LINE	BID CODE	ALT	DESCRIPTION	QUANTITY	UNIT	UNIT PRIC	FP	AMOUNT
3150	14003		W CAP EXISTING MAIN	2.00	EACH		\$	
3160	14014		W ENCASEMENT STEEL OPEN CUT RANGE 3	95.00	LF		\$	
3170	14059		W PIPE PVC 06 INCH	130.00	LF		\$	
3180	14066		W PIPE PVC SPECIAL	75.00	LF		\$	
3190	14094		W TIE-IN 06 INCH	2.00	EACH		\$	

221352

PROPOSAL BID ITEMS

Page 9 of 9

Report Date 9/21/22

Section: 0014 - DEMOBILIZATION &/OR MOBILIZATION

LINE	BID CODE	ALT	DESCRIPTION	QUANTITY	UNIT	UNIT PRIC	FP	AMOUNT
3200	02568		MOBILIZATION	1.00	LS		\$	
3210	02569		DEMOBILIZATION	1.00	LS		\$	